

VOLUNTEER WIRE ROPE

& SUPPLY CO., INC.

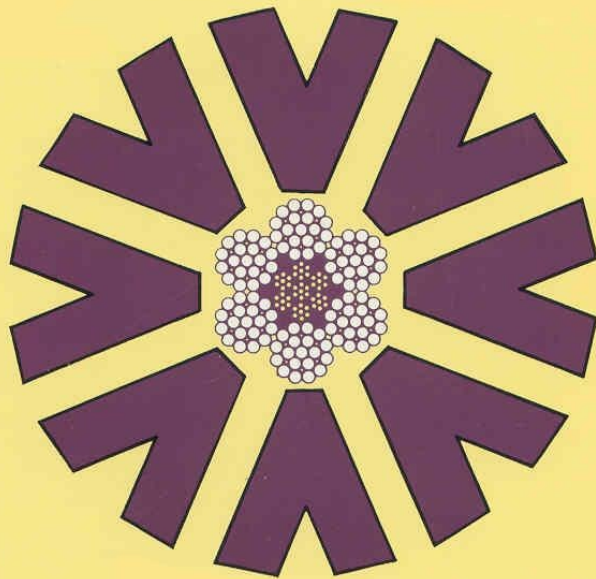

**2706 John Deere Drive
Knoxville, Tennessee 37917**

(800) 333-5789 (865) 546-8613 FAX (865) 522-6619
www.volwire.com

VOLUNTEER WIRE ROPE & SUPPLY CO., INC.

TERMS AND CONDITIONS OF SALE

CREDIT POLICY

All sales are subject to prior credit approval. We will fax or mail a credit application on request. One bank and three trade references are required.

TERMS OF SALE

Terms are *Net 30 Days, Date of Invoice*. Overdue invoices will be assessed an interest rate of one and one-half percent (1½%) for each month overdue.

CASH OPTIONS



Visa, MasterCard, American Express, and Discover are available for those who wish to use a charge card. Business or personal checks are acceptable with proper identification.

RETURNS & CLAIMS



No returns accepted without prior authorization. Unless otherwise agreed, a restocking charge of fifteen percent (15%) will apply against the original invoice cost or portion thereof and all freight charges remain due. Shortages and/or damaged freight must be noted immediately on the carriers delivery ticket. If necessary, obtain an inspection report from the carrier. Any claims should be filed directly with the delivering carrier on a timely basis.

WARRANTY



Any warranty, expressed or implied as to the quality, performance or fitness for use of any product purchased is always promised on the condition that limits apply only to new, unused product and that the equipment, mechanical or otherwise, in which such products are used is properly designed and maintained. That such products are properly stored, handled, used, maintained and inspected regularly. Buyers exclusive remedy for any and all losses or damages shall not exceed the purchase price of the materials.

All material is sold subject to **WARNINGS** that appear in this catalog.

IMPORTANT WARNINGS

READ ALL WARNINGS BEFORE USING THIS PUBLICATION
Failure to follow warnings and instructions may result in serious injury or death.

Anyone using this publication must read and understand all warning and other information listed below and preceding and/or adjacent to the product description. The following apply to all of the products in this catalog.

ALL WARNINGS AND SAFETY INFORMATION WILL BE HIGHLIGHTED IN ORANGE

All products are sold with the express understanding that the purchaser is thoroughly familiar with their correct application and safe use. *Use All Products Properly, In a Safe Manner And For The Application For Which They Were Intended.* Volunteer Wire Rope & Supply Co., Inc., assumes no responsibility for the use or misapplication of any product sold by this firm. Responsibility for design and use decisions rests with the user.

REMEMBER: ANY PRODUCT WILL BREAK IF ABUSED, MISUSED, OVERLOADED, OR NOT MAINTAINED PROPERLY. Such breaks can cause loads to fall or swing out of control, possibly resulting in serious injury or death as well as major property damage.

NEVER EXCEED THE WORKING LOAD LIMIT

The Working Load Limit is the maximum load which should ever be applied to the products, even when the product is new and when the load is uniformly applied—straight line pull only. Avoid side loading. All catalog ratings are based upon usual environmental conditions, and consideration must be given to unusual conditions such as extreme high or low temperatures, chemical solutions or vapors, prolonged immersion in salt water, etc. Such conditions or high-risk applications may necessitate reducing the Working Load Limit. There are other terms used in the industry which are interchangeable with the term Working Load Limit. These are: WLL, SWL, Safe Working Load, Value, Resulting Safe Working Load and Rated Capacity. Do not use breaking strength as a criterion for service or design purposes, refer to the Working Load Limit instead. Breaking strength is the average force at which the product, in the condition it would leave the factory, has been found by representative testing to break, when a constantly increasing force is applied in direct line to the product at a uniform rate of speed on a standard pull testing machine. Working Load Limit will not apply if the product has been welded or otherwise modified.

MATCH COMPONENTS PROPERLY

Make certain that components such as hooks, links, or shackles, etc., used with wire rope (or chain or cordage) are of suitable material and strength to provide adequate safety protection. Attachments must be properly installed and must have a Working Load Limit at least equal to the product with which they are used.

KEEP OUT FROM UNDER A RAISED LOAD

Conduct all lifting operations in such a manner, that if there were an equipment failure, no personnel would be injured. This means—*keep out from under a raised load and keep out of the line of force of any load.* Do not operate load over people. Do not ride on loads.

AVOID SHOCK LOADS

Avoid impacting, jerking, or swinging of load as the Working Load Limit could be exceeded and the Working Load Limit will not apply. A shock load is generally significantly greater than the static load.

INSPECT PRODUCTS REGULARLY

Inspect products prior to each use. No product can keep operating at its rated capacity indefinitely. Regular inspections help determine when to replace a product and reduce rigging hazards. Check for visible damage, cracks, wear, elongation, rust, corrosion, etc. When in doubt about the extent of the damage, withdraw the item from service. Keep inspection records to help pinpoint problems and to insure regular inspections.

DESTROY, RATHER THAN DISCARD ITEMS THAT HAVE BEEN JUDGED DEFECTIVE

They might be used again by someone not aware of the hazard associated with use.

WIRE ROPE



IMPORTANT WARNINGS

Failure to follow warnings and instructions can result in serious injury or death.

WIRE ROPE IS A MACHINE. Understand and respect it.

Like any machine, it needs proper care and maintenance for optimal safety and long service life. For a better understanding of wire rope we highly recommend the Wire Rope Users Manual by the Wire Rope Technical Board. Wire Rope Technical Board 515 King Street, Suite 420, Alexandria VA 22314-3137. Phone (703) 739-3753 • Fax (703) 684-6048

Rated Capacity.

Rated capacity is the load which a new wire rope may handle under given operating conditions and at an assumed design factor. A design factor of 5 is chosen most frequently for wire rope. (Operating loads not to exceed 20% of catalog Breaking Strength.) Operating loads may have to be reduced when life, limb or valuable property are at risk or other than new rope is used. A design factor of 10 is usually chosen when wire rope is used to carry personnel. (Operating loads not to exceed 10% of catalog Breaking Strength.)

Responsibility for choosing a design factor rests with the user.

Attachments must have at least the same Working Load Limit as the wire rope used.

Clips, sockets, thimbles, sleeves, hooks, links, shackles, sheaves, blocks, etc. must match in size, material and strength to provide adequate safety protection. **Proper installation is crucial for maximum efficiency and safety.**

Keep out from under a raised load.

Do not operate load over people. Do not ride on load. Conduct all lifting operations in such a manner that if equipment were to fail or break, no personnel would be injured. This means **KEEP OUT FROM UNDER A RAISED LOAD, DO NOT OPERATE LOADS OVER PEOPLE AND KEEP OUT OF THE LINE OF FORCE OF ANY LOAD.**

Avoid shock loads.

Avoid impacting, jerking or swinging of load. Working Load limit will not apply in these circumstances because a shock load is generally significantly greater than the static load.

Inspect wire rope regularly.

Use inspection instructions as guidelines only. Additional technical information on wire rope inspection can be obtained from the Wire Rope Technical Board. Two of the most important prerequisites for inspecting wire rope are technical knowledge and **experience.**

Check the general condition of the wire rope. Also, look for localized damage and wear, especially at the wire rope attachments. Inspect all parts that come in contact with the wire rope. Poor performance of wire rope can often be traced back to worn or wrong-sized sheaves, drums, rollers, etc. Look for kinks, broken wires, abrasions, lack of lubrication, rust damage, crushing, reduction of diameter, stretch or other obvious damage. If **any** of these conditions exist or if there is any other apparent damage to the wire rope, retire the wire rope according to the instructions below.

When in doubt about the extent of the damage, retire the wire rope in question immediately. Without laboratory analysis, it is **impossible** to determine the strength of damaged or used wire. Thus, you will not be able to tell whether wire rope with any amount of damage is safe to use. Retire the wire rope that is damaged. For specific inspection procedures check various OSHA and ANSI publications.

Destroy, rather than discard, wire rope to be retired.

Wire rope that is not destroyed might be used again by someone not aware of the hazard associated with that use. Destroying wire rope is best done by cutting it up into short pieces.

WIRE ROPE

6x19 CLASS ROPE

6x19 Classification Wire Ropes provide an excellent balance between fatigue and wear resistance. They will give long service with sheaves and drums of moderate size. The 6x25 Filler Wire (FW) Rope is the most flexible rope in the 6x19 classification. It is the most widely used of all wire ropes.

SPECIFICATION: RR-W-410D

EXTRA IMPROVED PLOW STEEL		
IWRC		
Diameter (Inches)	Approx. Weight per foot (Pounds)	Nominal Strength tons of 2000 lb.*
1/4	.116	3.40
5/16	.18	5.27
3/8	.26	7.55
7/16	.35	10.2
1/2	.46	13.3
9/16	.59	16.8
5/8	.72	20.6
3/4	1.04	29.4
7/8	1.42	39.8
1	1.85	51.7
1-1/8	2.34	65.0
1-1/4	2.89	79.9
1-3/8	3.50	96.0
1-1/2	4.16	114.
1-5/8	4.88	132.
1-3/4	5.67	153.
1-7/8	6.50	174.
2	7.39	198.

IMPROVED PLOW STEEL		
IWRC		
Diameter (Inches)	Approx. Weight per foot (Pounds)	Nominal Strength tons of 2000 lb.*
1/4	.116	2.94
5/16	.18	4.58
3/8	.26	6.56
7/16	.35	8.89
1/2	.46	11.5
9/16	.59	14.5
5/8	.72	17.9
3/4	1.04	25.6
7/8	1.42	34.6
1	1.85	44.9
1-1/8	2.34	56.5
1-1/4	2.89	69.4
1-3/8	3.50	83.5
1-1/2	4.16	98.9
1-5/8	4.88	115.
1-3/4	5.67	133.
1-7/8	6.50	152.
2	7.39	172.

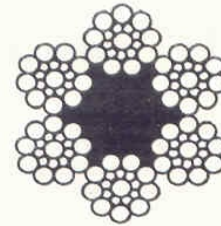

IMPROVED PLOW STEEL FIBER CORE		
Diameter (Inches)	Approx. Weight per foot (Pounds)	Nominal Strength tons of 2000 lb.*
1/4	.105	2.74
5/16	.164	4.26
3/8	.236	6.10
7/16	.32	8.27
1/2	.42	10.7
9/16	.53	13.5
5/8	.66	16.7
3/4	.95	23.8
7/8	1.29	32.2
1	1.68	41.8
1-1/8	2.13	52.6
1-1/4	2.63	64.6
1-3/8	3.18	77.7
1-1/2	3.78	92.0
1-5/8	4.44	107.
1-3/4	5.15	124.
1-7/8	5.91	141.
2	6.72	160.

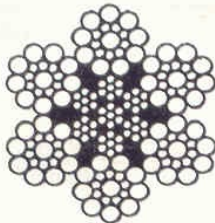

Wire rope products will break if abused, misused, or overused. Regular inspection and maintenance are necessary. Consult industry recommendations and applicable codes before using.

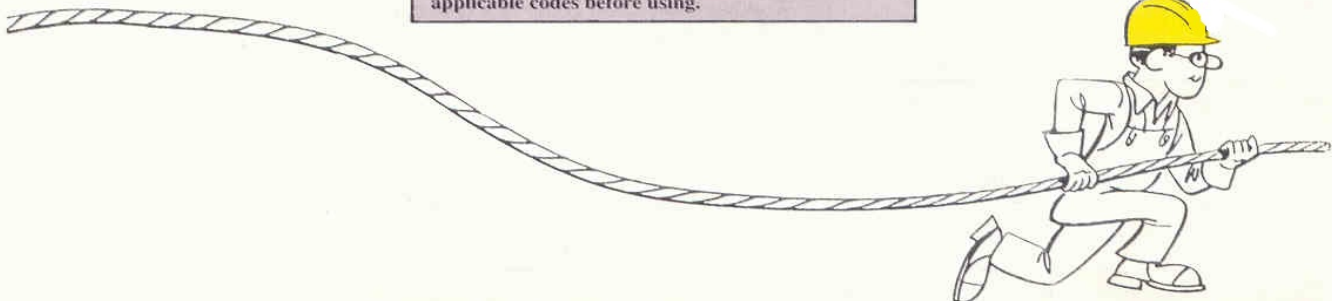

*Listed for comparison only. Actual operating loads may vary, but should never exceed the recommended design factor of 20% of catalog Nominal Strength.

WIRE ROPE

6X36 CLASS WIRE ROPE

6X36 Classification Wire Ropes have a third layer of wires which makes them more flexible, although less abrasion-resistant, than ropes of the 6x19 classification. Each strand contains numerous, small-diameter wires. As the number of wires in each strand is increased, flexibility is increased...as wires per strand decrease, flexibility is decreased.

SPECIFICATION: RR-W-410D

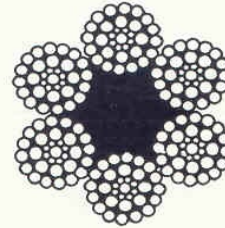

EXTRA IMPROVED PLOW STEEL		
IWRC		
Diameter (Inches)	Approx. Weight per foot (Pounds)	Nominal Strength tons of 2000 lb.*
1/4	.116	3.40
5/16	.18	5.27
3/8	.26	7.55
7/16	.35	10.2
1/2	.46	13.3
9/16	.59	16.8
5/8	.72	20.6
3/4	1.04	29.4
7/8	1.42	39.8
1	1.85	51.7
1-1/8	2.34	65.0
1-1/4	2.89	79.9
1-3/8	3.50	96.0
1-1/2	4.16	114.
1-5/8	4.88	132.
1-3/4	5.67	153.
1-7/8	6.50	174.
2	7.39	198.

IMPROVED PLOW STEEL		
IWRC		
Diameter (Inches)	Approx. Weight per foot (Pounds)	Nominal Strength tons of 2000 lb.*
1/4	.116	2.94
5/16	.18	4.58
3/8	.26	6.56
7/16	.35	8.89
1/2	.46	11.5
9/16	.59	14.5
5/8	.72	17.9
3/4	1.04	25.6
7/8	1.42	34.6
1	1.85	44.9
1-1/8	2.34	56.5
1-1/4	2.89	69.4
1-3/8	3.50	83.5
1-1/2	4.16	98.9
1-5/8	4.88	115.
1-3/4	5.67	133.
1-7/8	6.50	152.
2	7.39	172.

IMPROVED PLOW STEEL FIBER CORE		
Diameter (Inches)	Approx. Weight per foot (Pounds)	Nominal Strength tons of 2000 lb.*
1/4	.105	2.74
5/16	.164	4.26
3/8	.236	6.10
7/16	.32	8.27
1/2	.42	10.7
9/16	.53	13.5
5/8	.66	16.7
3/4	.95	23.8
7/8	1.29	32.2
1	1.68	41.8
1-1/8	2.13	52.6
1-1/4	2.63	64.6
1-3/8	3.18	77.7
1-1/2	3.78	92.0
1-5/8	4.44	107.
1-3/4	5.15	124.
1-7/8	5.91	141.
2	6.72	160.

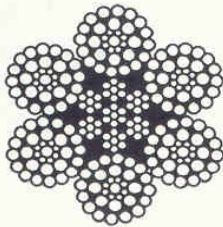

Wire rope products will break if abused, misused, or overused. Regular inspection and maintenance are necessary. Consult industry recommendations and applicable codes before using.

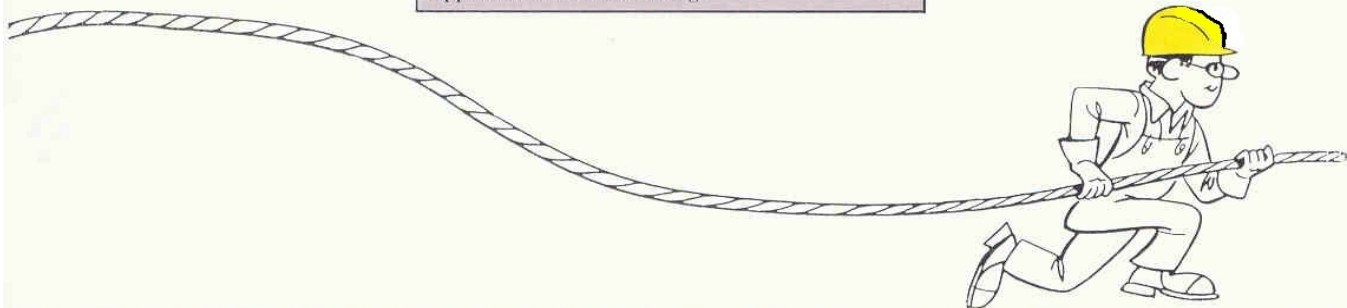

*Listed for comparison only. Actual operating loads may vary, but should never exceed the recommended design factor of 20% of catalog Nominal Strength.

WIRE ROPE

IWRC

6X19 IWRC

SPECIFICATION: RR-W-410D

IMPROVED PLOW STEEL / EXTRA IMPROVED PLOW STEEL

NOMINAL DIAMETER	MIN BREAKING STRENGTH		WEIGHT	STOCK NUMBER
	IPS	EIPS*		
INCH	LBS	LBS	LBS/FT	6 X 19
1/4"	5,880	6,800	0.116	J 45
5/16"	9,160	10,540	0.180	K 45
3/8"	13,120	15,100	0.260	L 45
7/16"	17,780	20,400	0.350	M 45
1/2"	23,000	26,600	0.460	N 45
9/16"	29,000	33,600	0.590	O 45
5/8"	35,800	41,200	0.720	A 45
3/4"	51,200	58,800	1.040	Q 45
7/8"	69,200	79,600	1.420	R 45
1"	89,800	103,400	1.850	S 45
1 1/8"	113,000	130,000	2.340	T 45
1 1/4"	138,000	159,800	2.890	U 45
1 3/8"	167,000	192,000	3.500	V 45
1 1/2"	197,000	228,000	4.160	W 45



6X36(WS) IWRC

SPECIFICATION: RR-W-410D

IMPROVED PLOW STEEL/EXTRA IMPROVED PLOW STEEL

NOMINAL DIAMETER	MIN BREAKING STRENGTH		WEIGHT	STOCK NUMBER
	IPS*	EIPS		
INCH	LBS	LBS	LBS/FT	6 X 36
1/4"	5,880	6,800	0.116	J 65
5/16"	9,160	10,540	0.18	K 65
3/8"	13,120	15,100	0.26	L 65
7/16"	17,780	20,400	0.35	M 65
1/2"	23,000	26,600	0.46	N 65
9/16"	29,000	33,600	0.59	O 65
5/8"	35,800	41,200	0.72	A 65
3/4"	51,200	58,800	1.04	Q 65
7/8"	69,200	79,600	1.42	R 65
1"	89,800	103,400	1.85	S 65
1 1/8"	113,000	130,000	2.34	T 65
1 1/4"	138,000	159,800	2.89	U 65
1 3/8"	167,000	192,000	3.50	V 65
1 1/2"	197,000	228,000	4.16	W 65

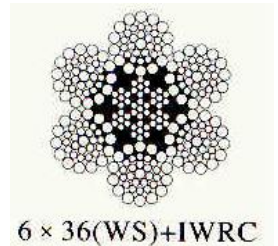

Wire rope products will break if abused, misused, or Overused. Regular inspection and maintenance are necessary. Consult industry recommendations and applicable codes before using.

*LISTED FOR COMPARISON ONLY. ACTUAL OPERATING LOADS MAY VARY, BUT SHOULD NEVER EXCEED THE RECOMMENDED DESIGN FACTOR OF 20% OF CATALOG NOMINAL STRENGTH.



WIRE ROPE

FIBER CORE

6 X 19 FC

SPECIFICATION: RR-W-410D

IMPROVED PLOW STEEL / EXTRA IMPROVED PLOW STEEL

NOMINAL DIAMETER INCH	MIN. BREAKING STRENGTH		WEIGHT LBS/FT	STOCK NUMBER 6X19
	IPS LBS	EIPS* LBS		
1/4"	5,480	6,300	0.105	J35
5/16"	8,520	9,800	0.164	K35
3/8"	12,200	14,000	0.236	L35
7/16"	16,540	19,000	0.320	M35
1/2"	21,400	24,600	0.420	N35
9/16"	27,000	31,100	0.530	O35
5/8"	33,400	38,400	0.660	A35
3/4"	47,600	54,700	0.950	Q35
7/8"	64,400	74,100	1.290	R35
1"	83,600	96,100	1.680	S35
1 1/8"	105,200	121,000	2.130	T35
1 1/4"	129,200	148,600	2.630	U35
1 3/8"	155,400	178,700	3.180	V35
1 1/2"	184,000	211,600	3.780	W35

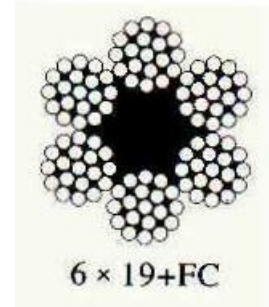

6 X 36 (WS) + FC

SPECIFICATION: RR-W-410D

IMPROVED PLOW STEEL/EXTRA IMPROVED PLOW STEEL

NOMINAL DIAMETER INCH	MIN. BREAKING STRENGTH		WEIGHT LBS/FT	STOCK NUMBER 6X36
	IPS* LBS	EIPS LBS		
1/4"	5,480	6,300	0.105	J55
5/16"	8,520	9,800	0.164	K55
3/8"	12,200	14,000	0.236	L55
7/16"	16,540	19,000	0.32	M55
1/2"	21,400	24,600	0.42	N55
9/16"	27,000	31,100	0.53	O55
5/8"	33,400	38,400	0.66	A55
3/4"	47,600	54,700	0.95	Q55
7/8"	64,400	74,100	1.29	R55
1"	83,600	96,100	1.68	S55
1 1/8"	105,200	121,000	2.13	T55
1 1/4"	129,200	148,600	2.63	U55
1 3/8"	155,400	178,700	3.18	V55
1 1/2"	184,000	211,600	3.78	W55

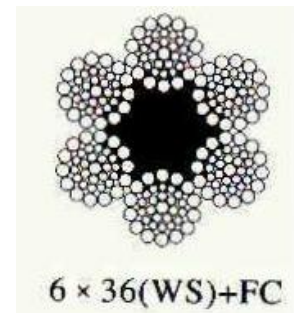

Wire rope products will break if abused, misused, or Overused. Regular inspection and maintenance are necessary. Consult industry recommendations and applicable codes before using.

*LISTED FOR COMPARISON ONLY. ACTUAL OPERATING LOADS MAY VARY, BUT SHOULD NEVER EXCEED THE RECOMMENDED DESIGN FACTOR OF 20% OF CATALOG NOMINAL STRENGTH.



WIRE ROPE

GALVANIZED IWRC SPECIFICATION: RR-W-410E

6 X 19 IWRC

IMPROVED PLOW STEEL / EXTRA IMPROVED PLOW STEEL

NOMINAL DIAMETER	MIN. BREAKING STRENGTH		WEIGHT	STOCK NUMBER
	IPS	EIPS*		
INCH	LBS	LBS	LBS/FT	6X19
1/4"	5,300	6,120	0.105	J42
5/16"	8,240	9,480	0.164	K42
3/8"	11,800	13,600	0.236	L42
7/16"	16,000	18,360	0.320	M42
1/2"	20,700	24,000	0.420	N42
9/16"	26,100	30,200	0.530	O42
5/8"	32,200	37,000	0.660	A42
3/4"	46,000	53,000	0.950	Q42
7/8"	62,200	71,600	1.290	R42
1"	80,800	93,000	1.680	S42
1 1/8"	101,800	117,000	2.130	T42
1 1/4"	125,000	143,800	2.630	U42
1 3/8"	150,400	172,800	3.180	V42
1 1/2"	178,000	206,000	3.780	W42

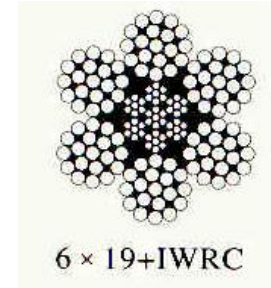

6 X 36 (WS) + IWRC

IMPROVED PLOW STEEL / EXTRA IMPROVED PLOW STEEL

NOMINAL DIAMETER	MIN. BREAKING STRENGTH		WEIGHT	STOCK NUMBER
	IPS*	EIPS		
INCH	LBS	LBS	LBS/FT	6X19
1/4"	5,300	6,120	0.105	J62
5/16"	8,240	9,480	0.164	K62
3/8"	11,800	13,600	0.236	L62
7/16"	16,000	18,360	0.320	M62
1/2"	20,700	24,000	0.420	N62
9/16"	26,100	30,200	0.530	O62
5/8"	32,200	37,000	0.660	A62
3/4"	46,000	53,000	0.950	Q62
7/8"	62,200	71,600	1.290	R62
1"	80,800	93,000	1.680	S62
1 1/8"	101,800	117,000	2.130	T62
1 1/4"	125,000	143,800	2.630	U62
1 3/8"	150,400	172,800	3.180	V62
1 1/2"	178,000	206,000	3.780	W62

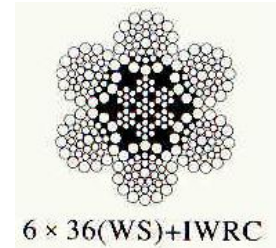

Wire rope products will break if abused, misused, or Overused. Regular inspection and maintenance are necessary. Consult industry recommendations and applicable codes before using.

*LISTED FOR COMPARISON ONLY. ACTUAL OPERATING LOADS MAY VARY, BUT SHOULD NEVER EXCEED THE RECOMMENDED DESIGN FACTOR OF 20% OF CATALOG NOMINAL STRENGTH.

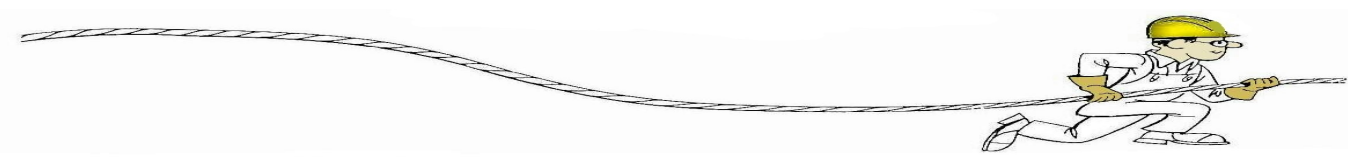

WIRE ROPE

ROTATION RESISTANT 8X19 CLASS, IWRC

EXTRA IMPROVED PLOW STEEL (EIPS)

NOMINAL DIAMETER	APPROX WEIGHT	MIN BREAKING STRENGTH UNGALV	STOCK NUMBER
INCH	LBS/FT	LBS	IWRC
3/8"	0.260	13,260	L77
7/16"	0.360	18,000	M77
1/2"	0.470	23,400	N77
9/16"	0.600	29,400	O77
5/8"	0.730	36,200	A77
3/4"	1.060	51,800	Q77
7/8"	1.440	70,000	R77
1"	1.880	91,000	S77
1 1/8"	2.390	114,600	T77

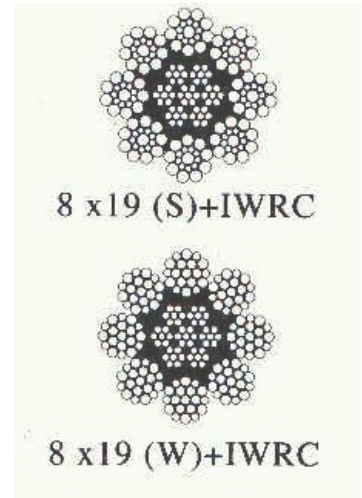

19X7 ROTATION RESISTANT

SPECIFICATION: RR-W-410D

EXTRA IMPROVED PLOW STEEL (EIPS)

NOMINAL DIAMETER	APPROX WEIGHT	MIN BREAKING STRENGTH UNGALV	STOCK NUMBER
(MINIMUM)			
INCH	LBS/FT	LB	19X7
3/16"	0.063	3,140	C75
1/4"	0.115	5,520	J75
5/16"	0.180	8,600	K75
3/8"	0.250	12,300	L75
7/16"	0.350	16,600	M75
1/2"	0.450	21,600	N75
9/16"	0.580	27,200	O75
5/8"	0.710	33,600	A75
3/4"	1.020	48,000	Q75
7/8"	1.390	65,000	R75
1"	1.820	84,400	S75

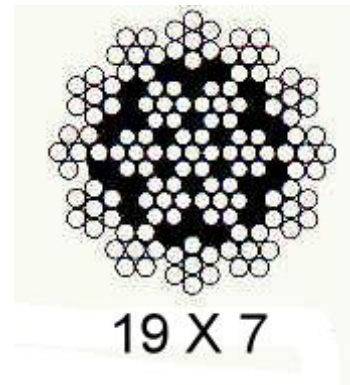

Wire rope products will break if abused, misused, or Overused. Regular inspection and maintenance are necessary. Consult industry recommendations and applicable codes before using.

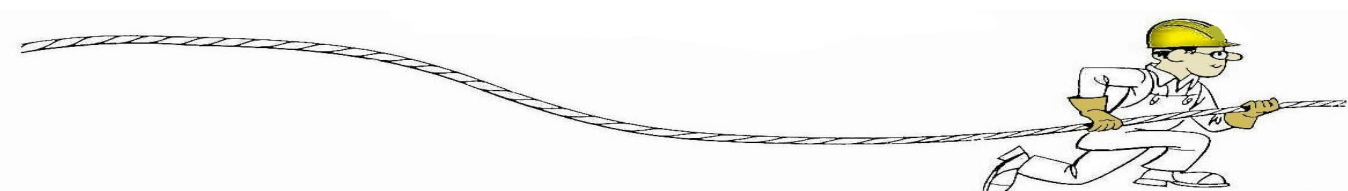

WIRE ROPE

DYTY-19 COMPACTED ROTATION RESISTANT

NOMINAL DIAMETER	APPROX WEIGHT	MIN BREAKING STRENGTH	STOCK NUMBER
INCH	LBS/FT	TONS	19X19
1/2"	0.51	14.15	N79
9/16"	0.65	17.90	O79
5/8"	0.81	22.75	A79
3/4"	1.14	32.30	Q79
7/8"	1.56	43.80	R79
1"	2.04	57.20	S79
1 1/8"	2.59	72.60	T79

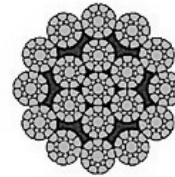

19 X 19

DYTY-6 COMPACTED

NOMINAL DIAMETER	APPROX WEIGHT	MIN BREAKING STRENGTH	STOCK NUMBER	
INCH	LB/FT	TONS	6X26	6X36
3/8"	0.27	8.80	L49	L69
7/16"	0.37	11.90	M49	M69
1/2"	0.48	15.30	N49	N69
9/16"	0.62	19.30	O49	O69
5/8"	0.76	22.70	A49	A69
3/4"	1.09	32.40	Q49	Q69
7/8"	1.49	43.80	R49	R69
1"	1.94	56.90	S49	S69
1 1/8"	2.46	71.50	T49	T69

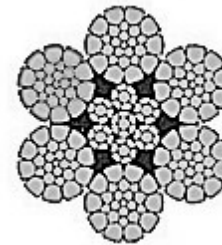

6 X 26

CABLE LAID WIRE ROPE 7X7X7 & 7X7X19

NOMINAL DIAMETER	APPROX WEIGHT		MIN BREAKING STRENGTH		STOCK NUMBER	
	LBS/FT					
INCH	7X7X7	7X7X19	7X7X7	7X7X19	7X7X7	7X7X19
1/4"	0.085	N/A	6,000 LBS	N/A	J10	N/A
3/8"	0.24	N/A	12,560 LBS	N/A	L10	N/A
1/2"	0.359	N/A	21,490 LBS	N/A	N10	N/A
9/16"	0.449	N/A	26,840 LBS	N/A	O10	N/A
5/8"	0.598	N/A	32,180 LBS	N/A	A10	N/A
3/4"	N/A	0.878	N/A	44,000 LBS	N/A	Q10
7/8"	N/A	1.105	N/A	58,400 LBS	N/A	R10
1"	N/A	1.337	N/A	74,290 LBS	N/A	S10
1 1/8"	N/A	2.026	N/A	91,700 LBS	N/A	T10

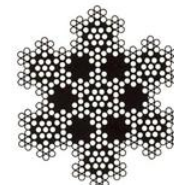

7 X 7 X 7

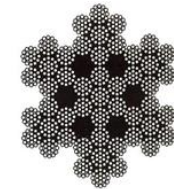

7 X 7 X 19

Wire rope products will break if abused, misused, or Overused. Regular inspection and maintenance are necessary. Consult industry recommendations and applicable codes before using.



WIRE ROPE

6X7 FIBERCORE SPECIFICATION: RR-W-410D

IMPROVED PLOW STEEL (IPS), RRL

ROPE DIAMETER		APPROX WEIGHT	MINIMUM BREAKING STRENGTH	STOCK NUMBER
NOMINAL (MINIMUM)	MAXIMUM			
INCH	INCH	LBS/FT	LBS/1000'	
1/4"	0.265	0.097	5,280	J85
5/16"	0.328	0.151	8,200	K85
3/8"	0.394	0.218	11,270	L85
7/16"	0.459	0.296	15,860	M85
1/2"	0.525	0.387	20,600	N85
9/16"	0.591	0.49	26,000	O85
5/8"	0.656	0.605	31,800	A85
3/4"	0.788	0.87	45,400	Q85

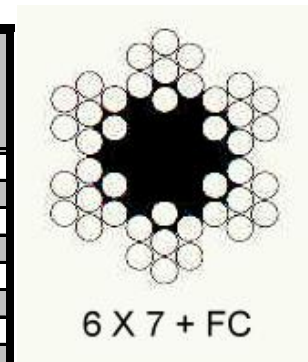

FURNISHED WITH HEAVY LUBE UNLESS REQUESTED OTHERWISE.

6X15+7 FIBER CORE BRITE LASHING

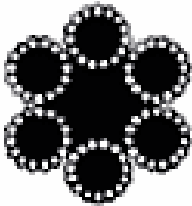

ROPE DIAMETER	APPROX WEIGHT	MINIMUM BREAKING	STOCK NUMBER
INCH	LBS/FT	LBS	
1/2"	0.25 LBS	11,400	N15-0001
5/8"	0.39 LBS	18,700	A15-0001
3/4"	0.56 LBS	26,900	Q15-0001
7/8"	0.76 LBS	36,300	R15-0001

HOT DIP GALVANIZED STRAND

SPECIFICATION: ASTM A 475

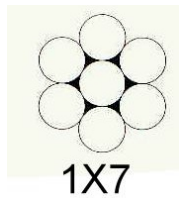

NOMINAL DIAMETER	CONSTRUCTION	NOMINAL DIAMETER OF WIRES	APPROX WEIGHT	MIN BREAKING STRENGTH	WEIGHT OF ZINC COATING (GRADE A)	STOCK NUMBER
				SIEMENS-MARTIN		
INCH		INCH	LBS/FT	LBS	OZ/SQ FT	
3/16"	1 X 7	0.062	0.073	1,900	0.50	H02
1/4"	1 X 7	0.080	0.121	3,150	0.60	J02
5/16"	1 X 7	0.109	0.205	5,350	0.80	K02
3/8"	1 X 7	0.120	0.273	6,950	0.80	L02
7/16"	1 X 7	0.145	0.399	9,350	0.90	M02
1/2"	1 X 7	0.165	0.516	12,100	0.90	N02
1/2"	1 X 19	0.100	0.504	12,100	0.70	N12

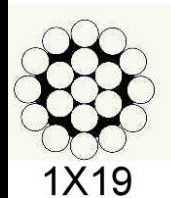

Wire rope products will break if abused, misused, or Overused. Regular inspection and maintenance are necessary. Consult industry recommendations and applicable codes before using.



WIRE ROPE

STAINLESS STEEL CABLE TYPE 302 – 304 (TYPE 316 AVAILABLE)

NOT FOR AIRCRAFT USE

SPECIFICATION: MIL-W-83420E

NOMINAL DIAMETER	TOLERANCE ON DIAMETER	APPROX WEIGHT	MIN BREAKING STRENGTH	STOCK NUMBER
INCHES	INCHES	LBS/1000'	LBS	
7 X 7				
1/32"	0.006	2.5	150 LBS	B13
3/64"	0.008	4.2	270 LBS	C13
1/16"	0.010	7.5	480 LBS	D13
3/32"	0.012	16	920 LBS	E13
1/8"	0.014	28.5	1700 LBS	F13
5/32"	0.016	43	2400 LBS	G13
3/16"	0.018	62	3700 LBS	H13
1/4"	0.018	106	6100 LBS	J13
5/16"	0.022	167	9000 LBS	K13
3/8"	0.026	236	12600 LBS	L13
7 X 19				
1/16"	0.010	7.5	480 LBS	D23
3/32"	0.012	17.4	920 LBS	E23
1/8"	0.014	29	1760 LBS	F23
5/32"	0.016	45	2400 LBS	G23
3/16"	0.018	65	3700 LBS	H23
7/32"	0.018	86	5000 LBS	I23
1/4"	0.018	110	6400 LBS	J23
5/16"	0.022	173	9000 LBS	K23
3/8"	0.026	243	12000 LBS	L23
1 X 19				
3/64"	0.008	4.7	280 LBS	C18
1/16"	0.010	8.4	500 LBS	D18
3/32"	0.012	18	1200 LBS	E18
1/8"	0.014	33.6	2100 LBS	F18
5/32"	0.016	52.5	3300 LBS	G18
3/16"	0.018	75.4	4700 LBS	H18
7/32"	0.018	102	6300 LBS	I18
1/4"	0.018	134	8200 LBS	J18
5/16"	0.022	210	12500 LBS	K18
3/8"	0.026	302	18000 LBS	L18
6X25				
7/16"	N/A	356 LBS	16,300 LBS	M43
1/2"	N/A	458 LBS	22,800 LBS	N43
9/16"	N/A	590 LBS	28,500 LBS	O43
5/8"	N/A	715 LBS	35,000 LBS	A43
3/4"	N/A	922 LBS	49,600 LBS	Q43
7/8"	N/A	1,430 LBS	66,500 LBS	R43
1"	N/A	1,870 LBS	85,400 LBS	S43

7 X 7

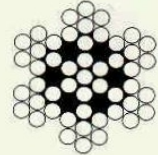

7 X 19

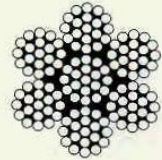

1 X 19

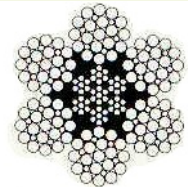
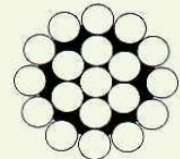

6X25

REEL LENGTHS AVAILABLE IN 250, 500, 1,000, 2,500, 3,000, AND 5,000 FEET
HOW TO ORDER: EXAMPLE 1/4" 7X19 X 500' REEL, ORDER: J23-0500

Wire rope products will break if abused, misused, or Overused. Regular inspection and maintenance are necessary. Consult industry recommendations and applicable codes before using



WIRE ROPE

PVC COATED CABLE

SPECIFICATION: MIL-W-83420E
IMPROVED PLOW STEEL (IPS)



7 X 7



7 X 19

DIAMETER		UNIT WEIGHT			BREAKING STRENGTH	STOCK NUMBER
INNER CABLE	OUTER COVER	INNER CABLE LBS/1000'	COATING LBS/1000'	TOTAL LBS/1000'		
7 X 7 PVC						
3/64"	1/16"	4.20	0.84	5.04	270	C1D
1/16"	3/32"	7.50	2.40	9.90	480	D1E
1/16"	1/8"	7.50	5.78	13.28	480	D1F
3/32"	1/8"	16.00	3.40	19.40	920	E1F
3/32"	3/16"	16.00	13.02	29.02	920	E1H
1/8"	3/16"	28.50	9.64	38.14	1,700	F1H
3/16"	1/4"	62.00	13.50	75.50	3,700	H1J
7 X 19 PVC						
1/8"	5/32"	29.00	4.34	33.34	2,000	F2G
1/8"	3/16"	29.00	9.64	38.64	2,000	F2H
5/32"	3/16"	45.00	18.80	63.80	2,800	G2H
3/16"	1/4"	65.00	13.50	78.50	4,200	H2J
1/4"	5/16"	110.00	17.40	127.40	7,000	J2K
5/16"	3/8"	173.00	21.20	194.20	9,800	K2L
5/16"	7/16"	173.00	46.30	219.30	9,800	K2M
3/8"	7/16"	243.00	25.10	268.10	14,400	L2M

6X19 PVC COATED

INSIDE WIRE DIAMETER	WEIGHT	MIN BREAKING STRENGTH	STOCK NUMBER
	LBS/1000 FT		
1/2"	490.00	23,000 LBS	N45P
9/16"	630.00	29,000 LBS	O45P
5/8"	780.00	35,800 LBS	A45P
3/4"	1130.00	51,200 LBS	Q45P
7/8"	1540.00	69,200 LBS	R45P
1"	2000.00	89,800 LBS	S45P

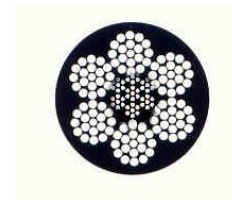

6 X 19

Wire rope products will break if abused, misused, or Overused. Regular inspection and maintenance are necessary. Consult industry recommendations and applicable codes before using



WIRE ROPE

GALVANIZED CABLE NOT FOR AIRCRAFT USE

SPECIFICATION: MIL-W-83420E

NOMINAL DIAMETER	TOLERANCE ON DIAMETER	APPROX WEIGHT	MIN BREAKING STRENGTH	STOCK NUMBER
INCHES	INCHES	LBS/1000'	LBS	
7 X 7				
3/64"	0.008	4.2	270 LBS	C12
1/16"	0.010	7.5	480 LBS	D12
3/32"	0.012	16	920 LBS	E12
1/8"	0.014	28.5	1700 LBS	F12
5/32"	0.016	43	2600 LBS	G12
3/16"	0.018	62	3700 LBS	H12
1/4"	0.018	106	6100 LBS	J12
5/16"	0.022	167	9200 LBS	K12
3/8"	0.026	236	13300LBS	L12
7 X 19				
3/32"	0.012	17.4	1000 LBS	E22
1/8"	0.014	29	2000 LBS	F22
5/32"	0.016	45	2800 LBS	G22
3/16"	0.018	65	4200 LBS	H22
7/32"	0.018	86	5600 LBS	I22
1/4"	0.018	110	7000 LBS	J22
5/16"	0.022	173	9800 LBS	K22
3/8"	0.026	243	14400 LBS	L22
1 X 19				
3/64"	0.008	4.7	280 LBS	C11
1/16"	0.010	8.4	500LBS	D11
3/32"	0.012	18	1200 LBS	E11
1/8"	0.014	33.6	2100 LBS	F11
5/32"	0.016	52.5	3300 LBS	G11
3/16"	0.018	75.4	4700 LBS	H11
1/4"	0.018	134	8200 LBS	J11
5/16"	0.022	210	12500 LBS	K11
3/8"	0.026	302	18000 LBS	L11

7 X 7

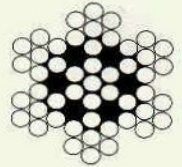

7 X 19

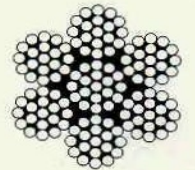

1 X 19



REEL LENGTHS AVAILABLE IN 250, 500, 1,000 & 5,000 FEET.

HOW TO ORDER:

EXAMPLE: 1/4" 7X19 X 500 FT REEL, ORDER: J22-0500

Wire rope products will break if abused, misused, or Overused. Regular inspection and maintenance are necessary. Consult industry recommendations and applicable codes before using



WIRE ROPE SLINGS

CAPACITY CHART



ROPE DIAMETER	RATED CAPACITY - TONS = 2,000 LBS						EYE DIMENSIONS	
	VERTICAL	CHOKER HITCH	BASKET HITCH			A INCHES	B INCHES	
			U	60 DEGREE	45 DEGREE			30 DEGREE
1/4"	0.65	0.48	1.3	1.1	0.94	0.65	2	4
5/16"	1	0.74	2	1.8	1.4	1	2 1/2	5
3/8"	1.4	1.1	2.9	2.6	2.1	1.4	3	6
7/16"	1.9	1.4	3.9	3.4	2.8	1.9	3 1/2	7
1/2"	2.5	1.9	5.1	4.5	3.7	2.5	4	8
9/16"	3.2	2.4	6.4	5.6	4.6	3.2	4 1/2	9
5/8"	3.9	2.9	7.8	6.9	5.6	3.9	5	10
3/4"	5.6	4.1	11	9.7	7.9	5.6	6	12
7/8"	7.6	5.6	15	13	10	7.1	7	14
1"	9.8	7.2	20	18	14	9.8	8	16
1 1/8"	12	9.1	24	21	17	12	9	18
1 1/4"	15	11	30	26	21	15	10	20
1 3/8"	18	13	36	32	26	18	11	22
1 1/2"	21	16	42	37	30	21	12	24
1 5/8"	24	18	49	43	35	24	13	26
1 3/4"	28	21	57	50	41	28	14	28
2"	37	28	74	65	53	37	16	32

SLING LOAD SELECTOR showing sling stresses at various angles

All Angles Measured from Vertical (1,000 lb. Load)

All Angles Measured from Vertical (1,000 lb. Load)
For Intermediate Angles Use Next Larger Angle

Example:

This chart illustrates how the stress on a sling increases as the angle increases (all angles measured from the vertical).

When one sling leg lifts 1,000 lbs. at 0 degrees, the sling stress is also 1,000 lbs. If the sling angle is increased to 45 degrees, the stress actually exerted on the sling would be 1,414 lbs., an increase of 41.4%.

Should the sling angle be increased to 60°, the stress would be 2,000 lbs., or a 100% increase. At an 85° angle (extremely unlikely) sling stress increases 1,047%. With a load of 1,000 lbs. the sling stress would be 11,473 lbs.

Sling charts on this page show rated capacities in tons of 2,000 lbs. with a design factor of 5. If in doubt of your exact angle always be SAFE. Use a higher angle on our Selector Chart. Always select a sling with the exact Rated Capacity or LARGER. Never use a sling with a lesser Rated Capacity. Always be safe - go safer - go to a larger Rated Capacity.

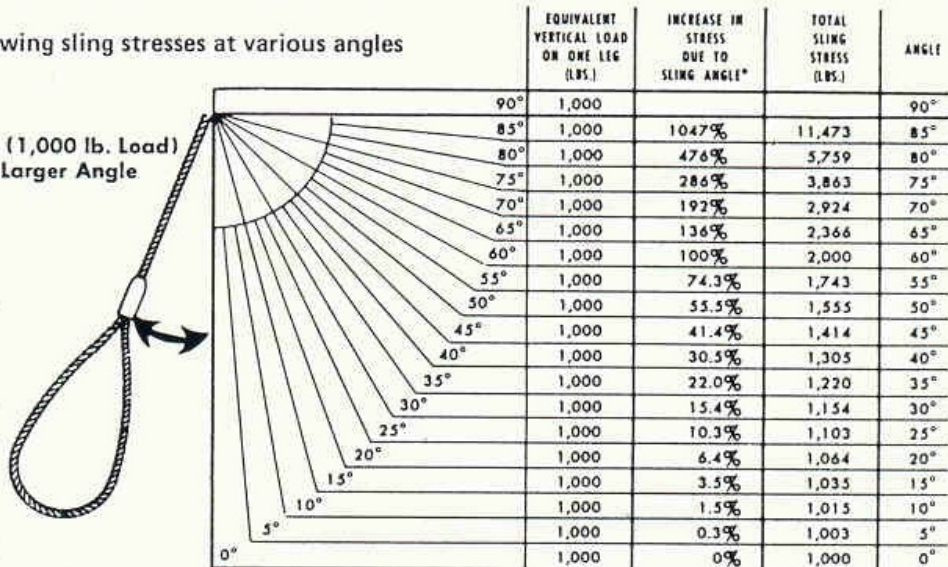

Wire rope products will break if abused, misused, or overused. Regular inspection and maintenance are necessary. Consult industry recommendations and applicable codes before using.

WIRE ROPE SLINGS

TYPE VWR101 TAPERED SLEEVE ATTACHMENTS

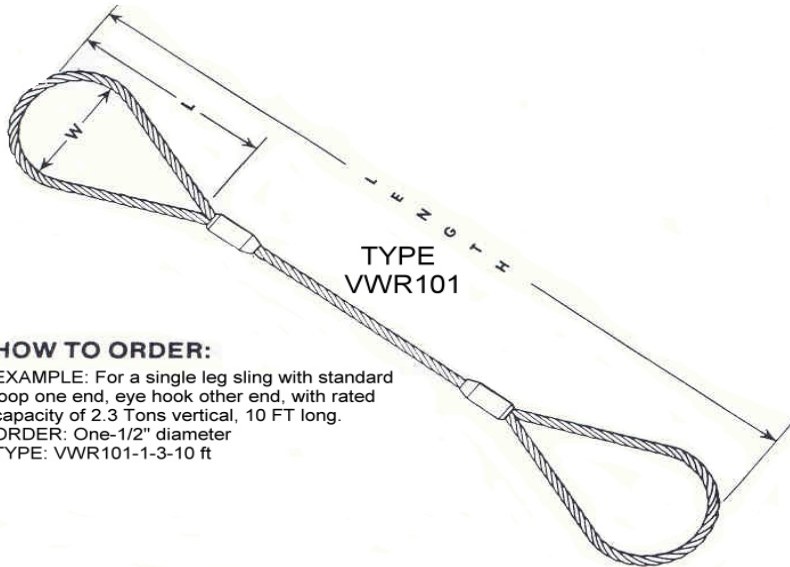

HOW TO ORDER:

EXAMPLE: For a single leg sling with standard loop one end, eye hook other end, with rated capacity of 2.3 Tons vertical, 10 FT long.
ORDER: One-1/2" diameter
TYPE: VWR101-1-3-10 ft

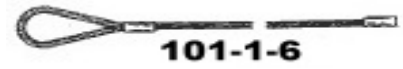
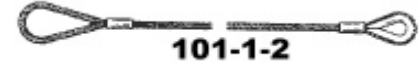

DIMENSIONS FOR END FITTINGS

ROPE DIAMETER	LOOP* 101-1-1		THIMBLE 101-1-2		ALLOY HOOK 101-1-3	SHACKLE W/THIMBLE 101-1-4	SWIVEL HOOK 101-1-5	BUTTON FERRULE 101-1-6		RATED CAPACITIES VERTICAL
	WIDTH/IN.	LENGTH/IN.	WIDTH/IN.	LENGTH/IN.				DIAMETER	LENGTH	
1/4"	2"	4"	7/8"	1 5/8"	1	5/16"	1	0.58	1.2	.59 TONS
5/16"	2 1/2"	5"	1 1/16"	1 7/8"	1 1/2	3/8"	1 1/2	0.77	1.33	.92 TONS
3/8"	3"	6"	1 1/8"	2 1/8"	3	7/16"	3	0.77	1.69	1.3 TONS
7/16"	3 1/2"	7"	1 1/4"	2 3/8"	3	1/2"	3	1.03	1.94	1.8 TONS
1/2"	4"	8"	1 1/2"	2 3/4"	3	1/2"	3	1.16	2.17	2.3 TONS
5/8"	5"	10"	1 3/4"	3 1/4"	4 1/2	5/8"	4 1/2	1.42	2.89	3.6 TONS
3/4"	6"	12"	2"	3 3/4"	7	3/4"	7	1.55	3.25	5.1 TONS
7/8"	7"	14"	2 1/4"	4 1/4"	7	7/8"	7	1.8	3.86	6.9 TONS
1"	8"	16"	2 1/2"	4 1/2"	11	1"	11	2.05	4.36	9 TONS
1 1/8"	9"	18"	2 7/8"	5 1/8"	11	1 1/8"	11	2.3	4.81	11 TONS
1 1/4"	11"	22"	2 7/8"	5 1/8"	15	1 1/4"	15	2.56	5.42	13 TONS
1 3/8"	12"	24"	3 1/2"	6 1/4"	22	1 3/8"	22	2.75	6	16 TONS
1 1/2"	13"	26"	3 1/2"	6 1/4"	22	1 1/2"	22	3	6.5	19 TONS

*STANDARD LOOP DIMENSIONS. OTHER SIZES FURNISHED WHEN SPECIFIED.

Wire rope products will break if abused, misused, or Overused. Regular inspection and maintenance are necessary. Consult industry recommendations and applicable codes before using

DO NOT EXCEED RATED CAPACITIES



WIRE ROPE SPREADER ASSEMBLIES

TWO-LEG SPREADER ASSEMBLY

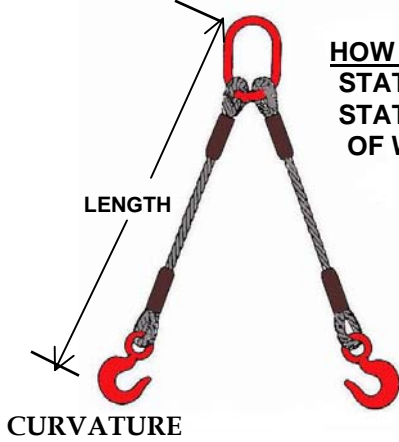
VWR-202 SINGLE ROPE LEGS
OBLONG LINK, EYE HOIST HOOKS,
FLEMISHED LOOPS. WITHOUT THIMBLES
TOP AND BOTTOM



HOW TO ORDER:
STATE STYLE: VWR202
STATE: SIZE & LENGTH
OF WIRE ROPE

WIRE ROPE DIA	RATED CAPACITY** HORIZONTAL ANGLES		
	 60°	 45°	 30°
1/4"	1.1T	.91T	.65T
5/16"	1.7T	1.4T	1T
3/8"	2.5T	2.0T	1.4T
7/16"	3.4T	2.7T	1.9T
1/2"	4.4T	3.6T	2.5T
5/8"	6.8T	5.5T	3.9T
3/4"	9.7T	7.9T	5.6T
7/8"	13T	11T	7.6T
1"	17T	14T	9.8T
1 1/8"	21T	17T	12T
1 1/4"	26T	21T	15T
1 3/8"	31T	25T	18T
1 1/2"	37T	30T	21T
1 3/4"	49T	40T	28T
2"	63T	52T	37T

** RATED CAPACITIES OF BASKET HITCHES ARE
BASED ON MINIMUM DIAMETER OF



AT THE POINT OF LOAD CONTACT OF 20 TIMES
THE ROPE DIAMETER

FOUR-LEG SPREADER ASSEMBLY

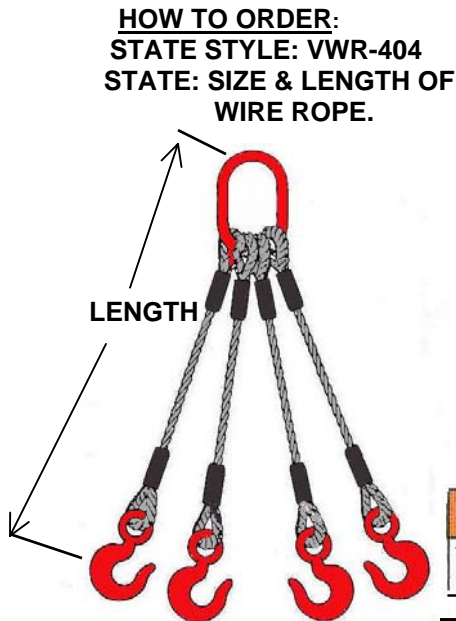
VWR-404 SINGLE ROPE LEGS
OBLONG LINK, EYE HOIST HOOKS,
FLEMISHED LOOPS. WITHOUT THIMBLES
TOP AND BOTTOM.



HOW TO ORDER:
STATE STYLE: VWR-404
STATE: SIZE & LENGTH OF
WIRE ROPE.

WIRE ROPE DIA	RATED CAPACITY** HORIZONTAL ANGLES		
	 60°	 45°	 30°
1/4"	2.2T	1.8T	1.3T
5/16"	3.5T	2.8T	2T
3/8"	5T	4.1T	2.9T
7/16"	6.7T	5.5T	3.9T
1/2"	8.8T	7.1T	5.1T
5/8"	14T	11T	7.8T
3/4"	19T	16T	11T
7/8"	26T	21T	15T
1"	34T	28T	20T
1 1/8"	42T	34T	24T
1 1/4"	51T	42T	30T
1 3/8"	62T	50T	36T
1 1/2"	73T	60T	42T
1 3/4"	98T	80T	57T
2"	127T	104T	73T

** RATED CAPACITIES OF BASKET HITCHES ARE
BASED ON MINIMUM DIAMETER OF CURVATURE
AT THE POINT OF LOAD CONTACT OF 20 TIMES
THE ROPE DIAMETER

NOTE: OTHER SIZES AVAILABLE UPON REQUEST.

WARNING

To prevent the possibility of serious bodily injury:
• DO NOT EXCEED the working load limits

DO NOT EXCEED RATED CAPACITIES

WIRE ROPE SLINGS

BRAIDED SLINGS

VWR-103-BR

8-part braided sling with braided loops and sleeves

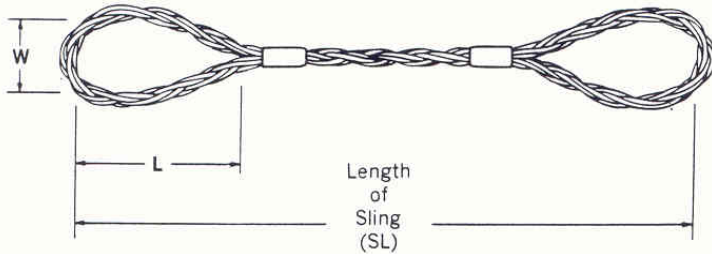

DIA OF INDIV ROPES***	RATED CAPACITIES**				
	CHOKER HITCH***	SINGLE LEG VERTICAL	BASKET HITCHES		
			60°	45°	30°
INCHES					
3/32	0.44	0.59	0.59	0.83	1
1/8	0.82	1.1	1.1	1.5	1.9
3/16	1.8	2.4	2.4	3.3	4.1
1/4	2.9	3.9	3.9	5.5	6.8
5/16	4.4	5.9	5.9	8.3	10
3/8	6.3	8.4	8.4	12	14
7/16	9.8	13	13	18	23
1/2	13	17	17	24	29
9/16	16	21	21	30	37
5/8	20	26	26	37	46

** Rated capacities are given in tons of 2,000 lbs using EIPS rope with IWRC. Rated capacities of basket hitches are based on minimum diameter of curvature at the point of load contact of 20 times the rope diameter.

***Rated capacities of choker hitches apply when the angle of choke is greater than 135 degrees.

****Larger sizes available upon request.

SLINGS W/ SLIDING CHOKER HOOK

DIA OF ROPE	RATED CAPACITY**	SPLICED LOOPS		SLIDING CHOKER HOOKS		
		WIDTH (INCHES)	LENGTH (INCHES)	SIZE	NO.	WEIGHT LBS
INCHES	IPS ROPE IWRC					
1/4	0.44	2	4	1/4-5/16	1	
3/8	0.69	3	6	3/8	0.8	
1/2	1.7	4	8	1/2	1.25	
5/8	2.7	5	10	5/8	5.5	
3/4	3.8	6	12	3/4	4.5	
7/8	5.2	7	14	7/8-1.0	10	
1	6.7	8	16	7/8-1.0	10	
1 1/8	8.5	9	18	1 1/8-1 1/4	26	
1 1/4	9.9	10	20	1 1/8-1 1/4	26	
1 3/8	12	11	22	1 3/8-1 1/2	42	
1 1/2	14	12	24	1 3/8-1 1/2	42	

VWR-101-CH
Sling with single-rope leg, Flemished loops and choker hooks.

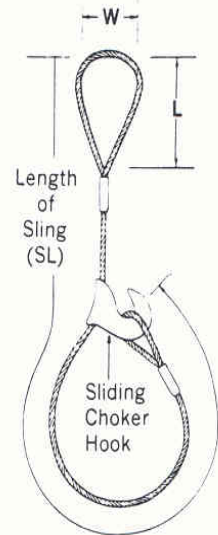

HOW TO ORDER:

STATE STYLE, SIZE, & LENGTH OF WIRE ROPE

**Rated capacities of choker hitches apply when the angle of choke is greater than 135degrees.

⚠ WARNING

To prevent the possibility of serious bodily injury:
 * DO NOT EXCEED the working load limits

WIRE ROPE SOCKET ASSEMBLIES

VWR-202 SWS SWAGE SOCKET

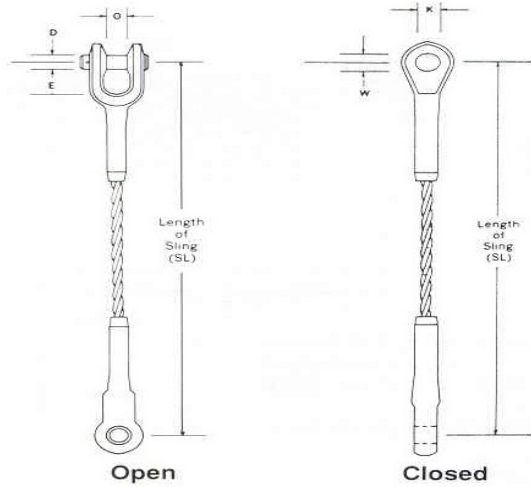

Diam of Rope in.	Open Swaged Socket			Closed Swaged Socket	
	O in.	D in.	E in.	K in.	W in.
1/4	1 1/16	1 1/16	1 1/32	1/2	3/4
3/8	1 3/16	1 3/16	1 1/32	1 1/16	7/8
1/2	1	1	1 1/2	7/8	1 1/16
5/8	1 1/4	1 3/16	1 2 1/32	1 1/8	1 1/4
3/4	1 1/2	1 3/8	2 1/16	1 1/16	1 3/16
7/8	1 3/4	1 5/8	2 7/16	1 1/2	1 11/16
1	2	2	2 3/4	1 3/4	2 1/16
1 1/8	2 1/4	2 1/4	3 1/8	2	2 5/16
1 1/4	2 1/2	2 1/2	3 1/2	2 1/4	2 3/16
1 3/8	2 1/2	2 1/2	4	2 1/4	2 3/16
1 1/2	3	2 3/4	4 3/8	2 1/2	2 13/16
1 3/4	3 1/2	3 1/2	5	3	3 1/16
2	4	3 3/4	6 1/8	3 1/4	3 13/16

Available open and/or closed with pins parallel or at right angles.

VWR-203 SPS SPELTER SOCKET

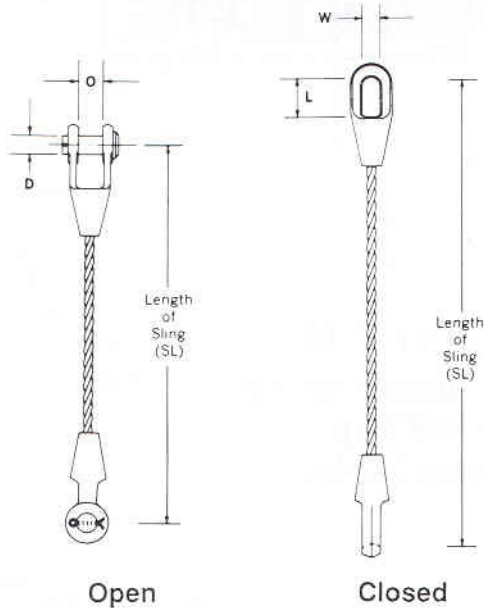

Diam of Rope in.	Open Sockets		Closed Sockets		
	O in.	D in.	W in.	L in.	K in.
3/8	1 3/16	1 7/16	1 5/16	2 1/16	5/8
1/2	1	1	1 1/8	2 5/16	7/8
5/8	1 1/4	1 3/16	1 3/8	2 3/16	1
3/4	1 1/2	1 3/8	1 5/8	3 1/16	1 1/4
7/8	1 3/4	1 5/8	1 7/8	3 3/16	1 1/2
1	2	2	2 1/4	4 1/16	1 3/4
1 1/8	2 1/4	2 1/4	2 1/2	4 3/16	2
1 1/4	2 1/2	2 1/2	2 3/4	5 1/8	2 1/4
1 3/8	2 1/2	2 1/2	2 3/4	5 1/8	2 1/4
1 1/2	3	2 3/4	3 1/8	6 1/8	2 1/2
1 5/8	3	3	3 1/4	6 1/2	2 3/4
1 3/4	3 1/2	3 1/2	3 1/32	7 1/16	3
2	4	3 3/4	3 23/32	8 1/16	3 1/4
2 1/4	4 1/2	4 1/4	4 3/32	9 3/4	3 5/8
2 1/2	5	4 3/4	5 3/8	11	4

Available open and/or closed with pins parallel or at right angles.

WARNING

To prevent the possibility of serious bodily injury:
 • DO NOT EXCEED the working load limits

WIRE ROPE ASSEMBLIES

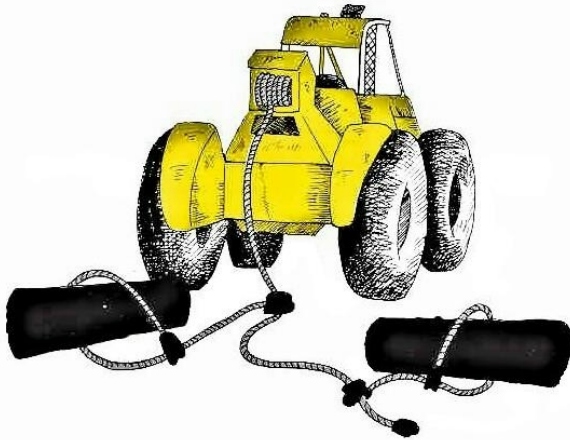

LOGGING CHOKERS



VLC2F
2 FERRULE



VLC1F/EOE
1 FERRULE/EYE ONE END

Additional configurations available.
Consult your sales representative.

9/16" LOG CHOKERS

LENGTH	WIRE TYPE	NUMBER OF FERRULES	SLIDE TYPE	UNIT	STOCK NO.
8'	IWRC	2	MICRO MIDGET	EA	LC916-8
8'	IWRC	2	MIDGET	EA	LC916-8/MS
8'	SWAGED	2	MIDGET	EA	LC916-8/SW
8'	IWRC	3	MICRO MIDGET	EA	LC916-8/3F
8'	IWRC	3	MIDGET	EA	LC916-8/3F-MS
8'	IWRC	4	MICRO MIDGET	EA	LC916-8/4F
9'	IWRC	2	MICRO MIDGET	EA	LC916-9
9'	IWRC	2	MIDGET	EA	LC916-9/MS
9'	SWAGED	2	MIDGET	EA	LC916-9/SW
9'	IWRC	3	MICRO MIDGET	EA	LC916-9/3F
9'	IWRC	3	MIDGET	EA	LC916-9/3F-MS
9'	IWRC	4	MICRO MIDGET	EA	LC916-9/4F
10'	IWRC	2	MICRO MIDGET	EA	LC916-10
10'	IWRC	2	MIDGET	EA	LC916-10/MS
10'	SWAGED	2	MIDGET	EA	LC916-10/SW
10'	IWRC	3	MICRO MIDGET	EA	LC916-10/3F
10'	IWRC	3	MIDGET	EA	LC916-10/3F-MS
10'	IWRC	4	MICRO MIDGET	EA	LC916-10/4F

WARNING

To prevent the possibility of serious bodily injury:
• DO NOT EXCEED the working load limits

WIRE ROPE ASSEMBLIES



LOGGING CHOKERS



VLC2F
2 FERRULE



VLC1F/EOE
1 FERRULE/EYE ONE END

Additional configurations available.
Consult your sales representative.

1/2" LOG CHOKERS

LENGTH	NUMBER OF FERRULES	SLIDE TYPE	UNIT	STOCK NO.
6'	2	MICRO MIDGET	EA	LC12-6
7'	2	MICRO MIDGET	EA	LC12-7
8'	2	MICRO MIDGET	EA	LC12-8
9'	2	MICRO MIDGET	EA	LC12-9
10'	2	MICRO MIDGET	EA	LC12-10

5/8" LOG CHOKERS

LENGTH	NUMBER OF FERRULES	SLIDE TYPE	UNIT	STOCK NO.
8'	2	DWARF	EA	LC58-8
9'	2	DWARF	EA	LC58-9
10'	2	DWARF	EA	LC58-10
12'	2	DWARF	EA	LC58-12

WARNING

To prevent the possibility of serious bodily injury:
 • DO NOT EXCEED the working load limits

WIRE ROPE ASSEMBLIES – LOGGING WINCH LINES

Wire rope products will break if abused, misused, or Overused. Regular inspection and maintenance are necessary. Consult industry recommendations and applicable codes before using

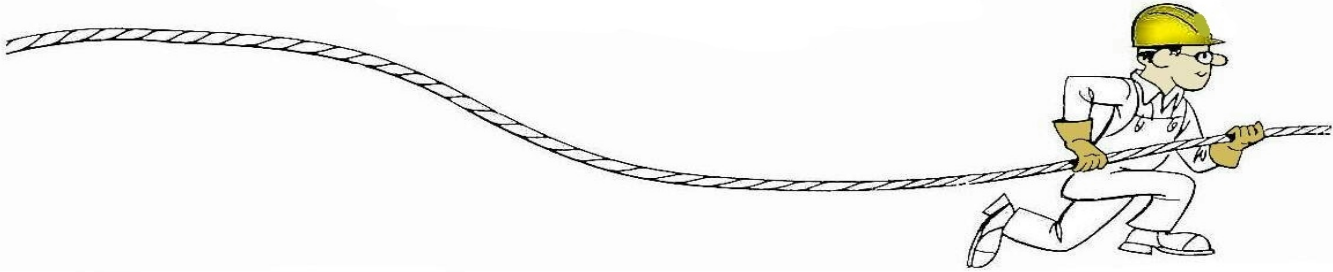

9/16" WINCH CABLE BUTTON ONE END

LENGTH	WIRE TYPE	UNIT	STOCK NO.
50'	SWAGED	EA	9/16X50SW/BOE
50'	IWRC	EA	9/16X50WC/BOE
75'	SWAGED	EA	9/16X75SW/BOE
100'	SWAGED	EA	9/16X100SW/BOE
125'	SWAGED	EA	9/16X125SW/BOE
150'	SWAGED	EA	9/16X150SW/BOE

5/8" WINCH CABLE BUTTON ONE END

LENGTH	WIRE TYPE	UNIT	STOCK NO.
50'	SWAGED	EA	5/8X50SW/BOE
50'	IWRC	EA	5/8X50WC/BOE
75'	SWAGED	EA	5/8X75SW/BOE
75'	IWRC	EA	5/8X75WC/BOE
100'	SWAGED	EA	5/8X100SW/BOE
100'	IWRC	EA	5/8X100WC/BOE
125'	SWAGED	EA	5/8X125SW/BOE
125'	IWRC	EA	5/8X125WC/BOE
150'	SWAGED	EA	5/8X150SW/BOE
150'	IWRC	EA	5/8X150WC/BOE

3/4" WINCH CABLE BUTTON ONE END

LENGTH	WIRE TYPE	UNIT	STOCK NO.
50'	SWAGED	EA	3/4X50SW/BOE
50'	IWRC	EA	3/4X50WC/BOE
75'	SWAGED	EA	3/4X75SW/BOE
75'	IWRC	EA	3/4X75WC/BOE
100'	SWAGED	EA	3/4X100SW/BOE
100'	IWRC	EA	3/4X100WC/BOE
125'	SWAGED	EA	3/4X125SW/BOE
125'	IWRC	EA	3/4X125WC/BOE
150'	SWAGED	EA	3/4X150SW/BOE
150'	IWRC	EA	3/4X150WC/BOE

WARNING
To prevent the possibility of serious bodily injury:
• DO NOT EXCEED the working load limits

CHAIN

CHAIN

GRADE 30 PROOF COIL



NOT TO BE USED FOR OVERHEAD LIFTING.

- Carbon Steel.
- Standard container—fiber drum.
- Finish—Self colored and Galvanized.
- Proof loaded at 2 times Working Load Limit.
- Minimum Ultimate load 4 times Working Load Limit.

Chain Size (in.)	Working Load Limit (lbs.)
$\frac{3}{16}$	800
$\frac{1}{4}$	1300
$\frac{5}{16}$	1900
$\frac{3}{8}$	2650
$\frac{1}{2}$	4500
$\frac{5}{8}$	6900
$\frac{3}{4}$	10600



NOT TO BE USED FOR OVERHEAD LIFTING.

- Carbon Steel.
- Standard container—fiber drum.
- Finish—Self colored.
- Proof loaded at 2 times Working Load Limit.
- Minimum Ultimate load 3 times Working Load Limit.

GRADE 40 HIGH TEST

Chain Size (in.)	Working Load Limit (lbs.)
$\frac{1}{4}$	2600
$\frac{5}{16}$	3900
$\frac{3}{8}$	5400
$\frac{7}{16}$	7200
$\frac{1}{2}$	9200
$\frac{5}{8}$	13000
$\frac{3}{4}$	20200

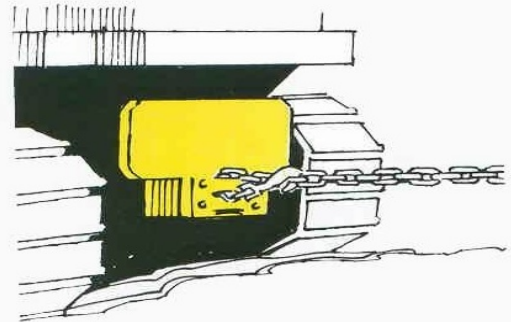

WARNING

To prevent the possibility of serious bodily injury:

- **DO NOT EXCEED** the working load limits for chain or components.
- **DO NOT USE** for overhead lifting or hoisting.
- **DO NOT USE** if the chain or components are visibly distorted or worn.

CHAIN

CHAIN

GRADE 70 - TRANSPORT

NOT TO BE USED FOR OVERHEAD LIFTING.

- High Tensile Carbon Steel.
- Standard container—fiber drum.
- Finish—Self colored.
- Proof loaded at 2 times Working Load Limit.
- Minimum Ultimate load 4 times Working Load Limit.

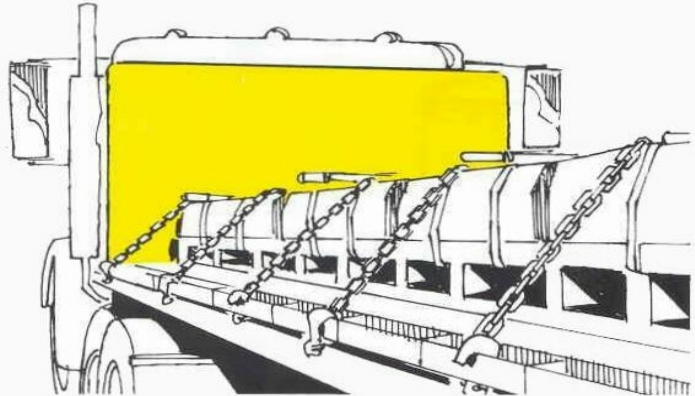

Chain Size (in.)	Working Load Limit (lbs.)
1/4	3150
5/16	4700
3/8	6600
7/16	8750
1/2	11300



GRADE 80—ALLOY

ALLOY CHAIN recommended for overhead lifting applications.



- Alloy Steel.
- Heat Treated.
- Finish—Self colored.
- Proof loaded at 2 times Working Load Limit.
- Minimum Ultimate load 4 times Working Load Limit.

Chain Size (in.)	Working Load Limit (lbs.)
5/32 (1/4)	3500
5/16	4500
3/8	7100
1/2	12000
5/8	18100
3/4	28300
7/8	34200

WARNING

To prevent the possibility of serious bodily injury:

- **DO NOT EXCEED** the working load limits for chain or components.
- **DO NOT USE** if the chain or components are visibly distorted or worn.

CHAIN

PROOF COIL GRADE 30 (INTERNATIONAL)



SIZE	FINISH*	WEIGHT	UNIT	DRUM PKG	WORKING LOAD LIMIT	STOCK NO.
3/16"	EG	0.33 LBS	FT	800'	800 LBS	00-0001
3/16"	HDG	0.40 LBS	FT	800'	800 LBS	00-0011
1/4"	EG	0.63 LBS	FT	400'/800'	1,300 LBS	10-0001
1/4"	SC	0.63 LBS	FT	400'/800'	1,300 LBS	11-0001
1/4"	HDG	0.63 LBS	FT	400'/800'	1,300 LBS	10-0011
5/16"	EG	0.91 LBS	FT	275'/550'	1,900 LBS	20-0001
5/16"	SC	0.91 LBS	FT	275'/550'	1,900 LBS	21-0001
5/16"	HDG	0.91 LBS	FT	275'/550'	1,900 LBS	20-0011
3/8"	EG	1.35 LBS	FT	200'/400'	2,650 LBS	30-0001
3/8"	SC	1.35 LBS	FT	200'/400'	2,650 LBS	31-0001
3/8"	HDG	1.35 LBS	FT	200'/400'	2,650 LBS	30-0011
1/2"	EG	2.42 LBS	FT	100'/200'	4,500 LBS	50-0001
1/2"	SC	2.42 LBS	FT	100'/200'	4,500 LBS	51-0001
1/2"	HDG	2.42 LBS	FT	100'/200'	4,500 LBS	50-0011
5/8"	HDG	3.67 LBS	FT	150'		60-0011
3/4"	HDG	5.76 LBS	FT	100'		70-0011
1"	HDG	9.49 LBS	FT	60'		90-0011

*EG =ELECTRO-GALVANIZED *HDG = HOT DIPPED GALVANIZED *SC =SELF COLORED



550' 800'

PROOF COIL GRADE 30 (DOMESTIC)



275' 400'

SIZE	FINISH*	WEIGHT	UNIT	DRUM PKG	WORKING LOAD LIMIT	STOCK NO.
3/16"	EG	0.21 LBS	FT	800'	800 LBS	00-0051
1/4"	EG	0.69 LBS	FT	400'/800'	1,300 LBS	10-0051
1/4"	SC	0.69 LBS	FT	400'/800'	1,300 LBS	11-0051
5/16"	EG	1.00 LBS	FT	275'/550'	1,900 LBS	20-0051
5/16"	SC	1.00 LBS	FT	275'/550'	1,900 LBS	21-0051
3/8"	EG	1.45 LBS	FT	275'/550'	2,650 LBS	30-0051
3/8"	SC	1.45 LBS	FT	275'/550'	2,650 LBS	31-0051

*EG = ELECTRO-GALVANIZED

*SC = SELF COLORED

PROOF COIL- EG-GRADE 30 (PAILS)



500', 250', 141', 92', 63'

SIZE	FINISH*	WEIGHT	UNIT	PAIL QTY	WORKING LOAD LIMIT	STOCK NO.
1/8"	EG	75.00 LBS	PAIL	500'	375 LBS	0-0099
3/16"	EG	87.50 LBS	PAIL	250'	800 LBS	00-0099
1/4"	EG	90.00 LBS	PAIL	141'	1,300 LBS	10-0099
5/16"	EG	85.00 LBS	PAIL	92'	1,900 LBS	20-0099
3/8"	EG	86.00 LBS	PAIL	63'	2,650 LBS	30-0099

*EG = ELECTRO-GALVANIZED

*SC = SELF COLORED

WARNING

To prevent the possibility of serious bodily injury:

- DO NOT EXCEED the working load limits for chain or components.
- DO NOT USE for overhead lifting or hoisting.
- DO NOT USE if the chain or components are visibly distorted or worn.

CHAIN

HIGH TEST GRADE 40 NACM 90 (INTERNATIONAL)



SIZE	FINISH*	WEIGHT	UNIT	DRUM PKG	WORKING LOAD LIMIT	STOCK NO.
1/4"	SC	0.69 LBS	FT	400'/800' DR	2,600 LBS	12-0001
1/4"	SC	89.00 LBS	PL	141' PAIL	2,600 LBS	12-0009
1/4"	EG	0.69 LBS	FT	400'/800' DR	2,600 LBS	15-0001
1/4"	EG	89.00 LBS	PL	141' PAIL	2,600 LBS	15-0009
1/4"	HDG	0.69 LBS	FT	400'/800' DR	2,600 LBS	15-0011
5/16"	SC	1.00 LBS	FT	275'/550' DR	3,900 LBS	22-0001
5/16"	SC	92.00 LBS	PL	92' PAIL	3,900 LBS	22-0009
5/16"	EG	1.00 LBS	FT	275'/550' DR	3,900 LBS	25-0001
5/16"	EG	92.00 LBS	PL	92' PAIL	3,900 LBS	25-0009
5/16"	HDG	1.00 LBS	FT	275'/550' DR	3,900 LBS	25-0011
3/8"	SC	1.45 LBS	FT	200'/400' DR	5,400 LBS	32-0001
3/8"	SC	89.00 LBS	PL	63' PAIL	5,400 LBS	32-0009
3/8"	EG	1.45 LBS	FT	200'/400' DR	5,400 LBS	35-0001
3/8"	EG	89.00 LBS	PL	63' PAIL	5,400 LBS	35-0009
3/8"	HDG	1.45 LBS	FT	200'/400' DR	5,400 LBS	35-0011
1/2"	SC	2.65 LBS	FT	100'/200' DR	9,200 LBS	52-0001
1/2"	EG	1.39 LBS	FT	100'/200' DR	9,200 LBS	55-0001
5/8"	SC	3.57 LBS	FT	150' DR	13,000 LBS	62-0001
3/4"	SC	5.60 LBS	FT	100' DR	20,200 LBS	72-0001

*EG= ELECTRO GALVANIZED *HDG = HOT DIPPED GALVANIZED

*SC= SELF COLORED



550' 800'

HIGH TEST GRADE 40 (DOMESTIC)



275' 400'

SIZE	FINISH	WEIGHT	UNIT	DRUM PKG	WORKING LOAD LIMIT	STOCK NO.
1/4"	SELF COLORED	0.69 LBS	FT	400'/800'	2,600 LBS	12-0051
5/16"	SELF COLORED	1.00 LBS	FT	275'/550'	3,900 LBS	22-0051
3/8"	SELF COLORED	1.45 LBS	FT	200'/400'	5,400 LBS	32-0051
1/2"	SELF COLORED	2.65 LBS	FT	100'/200'	9,200 LBS	52-0051

SYSTEM 7 CHAIN GRADE 70 (INTERNATIONAL)

NOT FOR OVERHEAD LIFTING



SIZE	FINISH	WEIGHT	UNIT	DRUM PKG	WORKING LOAD LIMIT	STOCK NO.
1/4"	CHROMATE	0.74 LBS	FT	400'/800'	3,150 LBS	13-0001
5/16"	CHROMATE	1.00 LBS	FT	275'/550'	4,700 LBS	23-0001
3/8"	CHROMATE	1.45 LBS	FT	200'/400'	6,600 LBS	33-0001
1/2"	CHROMATE	2.46 LBS	FT	100'/200'	11,300 LBS	53-0001

WARNING

To prevent the possibility of serious bodily injury:

- DO NOT EXCEED the working load limits for chain or components.
- DO NOT USE for overhead lifting or hoisting.
- DO NOT USE if the chain or components are visibly distorted or worn.

CHAIN

SYSTEM 7 CHAIN GRADE 70 (DOMESTIC) NOT FOR OVERHEAD LIFTING



SIZE	FINISH	WEIGHT	UNIT	DRUM PKG	WORKING LOAD LIMIT	STOCK NO.
1/4"	CHROMATE	0.74 LBS	FT	400'/800'	3,150 LBS	18-DRUM
5/16"	CHROMATE	1.00 LBS	FT	275'/550'	4,700 LBS	28-DRUM
3/8"	CHROMATE	1.45 LBS	FT	200'/400'	6,600 LBS	38-DRUM
1/2"	CHROMATE	2.46 LBS	FT	100'/200'	11,300 LBS	58-DRUM

ALLOY CHAIN-GRADE 80 (DOMESTIC) FOR OVERHEAD LIFTING



SIZE	FINISH	WEIGHT	UNIT	DRUM PKG	WORKING LOAD LIMIT	STOCK NO.
9/32"	SELF COLORED	0.74 LBS	FT	400'/800'	3,500 LBS	19-DRUM
5/16"	SELF COLORED	1.00 LBS	FT	275'/550'	4,500 LBS	29-DRUM
3/8"	SELF COLORED	1.45 LBS	FT	200'/400'	7,100 LBS	39-DRUM
1/2"	SELF COLORED	2.64 LBS	FT	100'/200'	12,000 LBS	59-DRUM
5/8"	SELF COLORED	3.51 LBS	FT	150'	18,100 LBS	69-DRUM
3/4"	SELF COLORED	5.84 LBS	FT	100'	28,300 LBS	74-DRUM
7/8"	SELF COLORED	7.05 LBS	FT	100'	34,200 LBS	84-DRUM
1"	SELF COLORED	10.02 LBS	FT	100'	47,700 LBS	94-DRUM
1 1/4"	SELF COLORED	15.25 LBS	FT	60'	72,300 LBS	99-DRUM

ALLOY CHAIN – GRADE 100 FOR OVERHEAD LIFTING



SIZE	FINISH	WEIGHT LBS/FT	UNIT	DRUM PKG	WORKING LOAD LIMIT	STOCK NO.
9/32"	SELF COLORED	0.74 LBS	FT	500'	4,300 LBS	190-DRUM
5/16"	SELF COLORED	1.00 LBS	FT	500'	5,700 LBS	290-DRUM
3/8"	SELF COLORED	1.48 LBS	FT	500'	8,800 LBS	390-DRUM
1/2"	SELF COLORED	2.50 LBS	FT	300'	15,000 LBS	590-DRUM
5/8"	SELF COLORED	3.79 LBS	FT	200'	22,600 LBS	690-DRUM
3/4"	SELF COLORED	5.98 LBS	FT	100'	35,300 LBS	740-DRUM
7/8"	SELF COLORED	7.75 LBS	FT	100'	42,700 LBS	840-DRUM

WARNING

To prevent the possibility of serious bodily injury:

- * DO NOT EXCEED the working load limits for chain or components.
- * DO NOT USE if the chain or components are visibly distorted or worn.

CHAIN - STAINLESS STEEL

TYPE 316 CHAIN

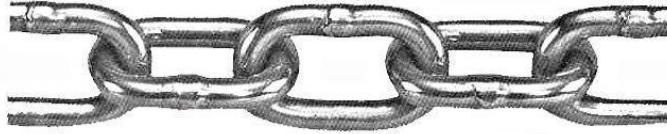

SIZE	WEIGHT	UNIT	STOCK NO.
1/8"	0.17 LBS/FT	FT	991504
3/16"	0.38 LBS/FT	FT	991506
1/4"	0.61 LBS/FT	FT	991509
5/16"	0.95 LBS/FT	FT	991510
3/8"	1.40 LBS/FT	FT	991513
1/2"	2.34 LBS/FT	FT	991517

TYPE 304 CHAIN

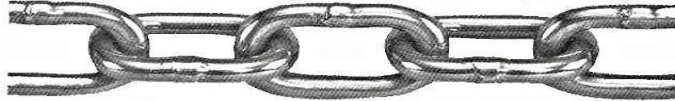

SIZE	TYPE	STANDARD	WEIGHT	UNIT	STOCK NO.
5/32"	PC	ASTM 80	0.20 LBS/FT	FT	991505
5/32"	HT	ASTM 80		FT	991555
1/4"	PC	ASTM 80	0.60 LBS/FT	FT	991508
1/4"	HT	ASTM 80		FT	991558
3/8"	PC	ASTM 80	1.38 LBS/FT	FT	991512
3/8"	HT	ASTM 80		FT	991562
1/2"	PC	ASTM 80	2.43 LBS/FT	FT	991516
1/2"	HT	ASTM 80		FT	991566

BOWTYE CHAIN



SIZE	WEIGHT	UNIT	STOCK NO.
#1	0.17 LBS/FT	FT	991501
#3	0.19 LBS/FT	FT	991503

⚠ WARNING

To prevent the possibility of serious bodily injury:

- **DO NOT EXCEED** the working load limits for chain or components.
- **DO NOT USE** for overhead lifting or hoisting.
- **DO NOT USE** if the chain or components are visibly distorted or worn.

CHAIN SLINGS

CHAIN SLINGS

INSPECTION, CARE AND PROPER USE OF CHAIN SLINGS

INSTRUCTIONS REGARDING ATTACHMENTS

Where attachments, such as hooks or rings, are designed for use with chain in sustaining loads, care should be taken to select type, grade and size recommended. Attachments shall be rated to the capacity of the weakest component. Volunteer Wire Rope & Supply Co., Inc. offers a full line of Alloy sling components engineered specifically to be compatible with our chain products.



CAUTIONS AND WARNINGS

The use of chain is subject to certain hazards that cannot be met by mechanical or manufacturing means, but only by the exercise of intelligence, care, and common sense. Sling use is subject to OSHA safety regulations, requiring the user to conduct safe working practices and perform inspections.

NEVER EXCEED THE WORKING LOAD LIMIT OF CHAIN FOR ANY REASON !

Volunteer Wire Rope & Supply Co., Inc. denies any liability for damage which may result from use in excess of the working load limit. Any abuse or misuse of the product may lessen the load the product will withstand. Some examples of such changes or abuses are:

- Overloading or previous overload,**
- Twisting,**
- Bending, especially over sharp corners or edges,**
- Gouges, nicks, kinks, or pressure marks,**
- Shock loading, or**
- Use in chemically active environments.**



Additional cautions and instructions pertaining to sling use are:

- **Do not rest load on chain.**
- **Inspect load at contact with hooks to be sure the load is properly seated within the throat opening.**
- **Balance the load. Unbalanced loads can put too much stress on one leg of multiple chain slings.**
- **Never bounce or jerk load when lowering or lifting.**
- **Never force or hammer hooks or chain into position.**
- **Store chain slings in a clean dry area, preferably by hanging on racks or walls rather than placing slings on floors where they are subject to abuse.**
- **Never anneal alloy slings. Return sling to factory for proper repair procedures.**
- **Do not use in acid solutions. Consult manufacturer for recommendations.**
- **Clean chain slings regularly as dirt and grit can cause wear at link bearing points**
- **A link-by-link inspection will afford an opportunity to discover deep gouges, distortion, spread in the throat opening of hooks and damage to master links and coupling links. An inspection can also detect elongation of the legs themselves (i.e. reach) and should also include a link-by-link inspection to uncover individual link wear.**

OSHA REQUIRES THAT ANY CHAIN SLING WHICH HAS EXPERIENCED TEMPERATURES IN EXCESS OF 1000 DEGREES FAHRENHEIT BE REMOVED FROM SERVICE.

CHAIN SLINGS

CHAIN SLINGS

ORDERING INFORMATION

PLEASE USE INFORMATION BELOW WHEN ORDERING CHAIN SLINGS.

STYLE CODES

SINGLE SLINGS

CODES

VCO	OBLONG MASTER LINK EACH END
VSOS	OBLONG MASTER LINK ONE END & SLIP HOOK OTHER END
VSOG	OBLONG MASTER LINK ONE END & GRAB HOOK OTHER END
VSSG	SLIP HOOK ONE END & GRAB HOOK OTHER END
VSSS	SLIP HOOK EACH END
VSOE	OBLONG MASTER LINK ONE END & FOUNDRY HOOK OTHER END

DOUBLE SLINGS

VDOE	OBLONG MASTER LINK ONE END & SLIP HOOKS OTHER ENDS
VDOG	OBLONG MASTER LINK ONE END & GRAB HOOKS OTHER ENDS
VDOF	OBLONG MASTER LINK ONE END & FOUNDRY HOOKS OTHER ENDS

TRIPLE SLINGS

VTOS	OBLONG MASTER LINK ONE END & SLIP HOOKS OTHER ENDS
I.E.:	
VTOG	OBLONG MASTER LINK ONE END & GRAB HOOKS OTHER ENDS

QUADRUPLE SLINGS

VQOS	OBLONG MASTER LINK ONE END & SLIP HOOKS OTHER ENDS
VQOG	OBLONG MASTER LINK ONE END & GRAB HOOKS OTHER ENDS

CHAIN SIZE

9/32"	14-
5/16"	516-
3/8"	38-
1/2"	12-
5/8"	58-
3/4"	34-
7/8"	78-
1"	100-
1 1/4"	125-

LENGTH CODES

LENGTH CODES ARE EQUAL TO THE DESIRED LENGTH

12' = 12, 6' = 6 ETC.

SAMPLE OF ORDERING CODE

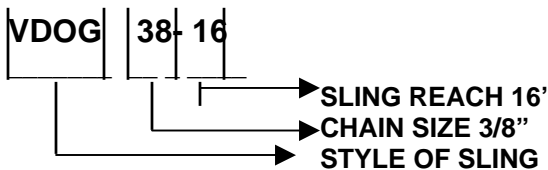

IF YOU NEED HELP IN ORDERING, ASK YOUR SALES REPRESENTATIVE. THEY WILL BE MORE THAN HAPPY TO ASSIST YOU.

⚠ WARNING

To prevent the possibility of serious bodily injury:

- **DO NOT EXCEED** the working load limits for chain or components.
- **DO NOT USE** if the chain or components are visibly distorted or worn.

CHAIN SLINGS

CHAIN SLINGS

SINGLE TYPES: VS AND VC

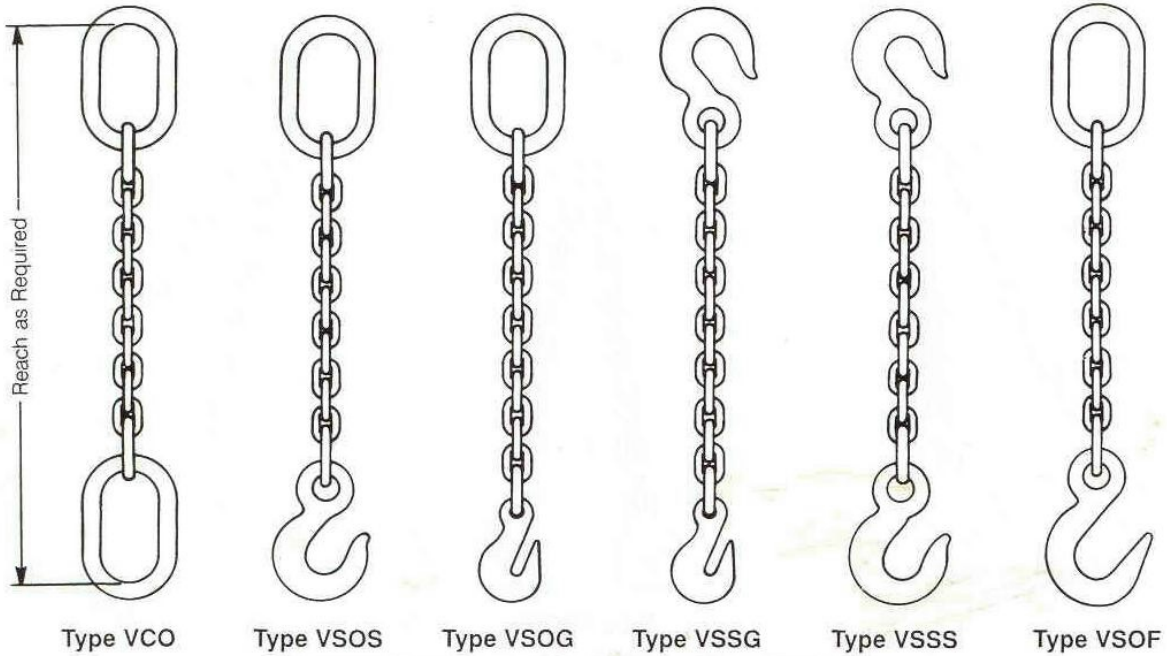

Other configurations available. Ask your sales representative.

Specifications and Working Load Limits

Oblong Master Link, Inches Dimensions are approximate.				
Chain Size Inches	Nominal Size Material	Inside Width	Inside Lgth.	Working Load Limit Pounds
9/32	1/2	2-1/2	5	3500
3/8	3/4	3	6	7100
1/2	1	4	8	12000
5/8	1	4	8	18100
3/4	1-1/4	5	10	28300
7/8	1-1/2	6	12	34200
1	1-3/4	6	12	47700
1-1/4	2	7	14	72300

⚠ WARNING

To prevent the possibility of serious bodily injury:

- **DO NOT EXCEED** the working load limits for chain or components.
- **DO NOT USE** if the chain or components are visibly distorted or worn.

CHAIN SLINGS

CHAIN SLINGS

DOUBLE TYPE: VD

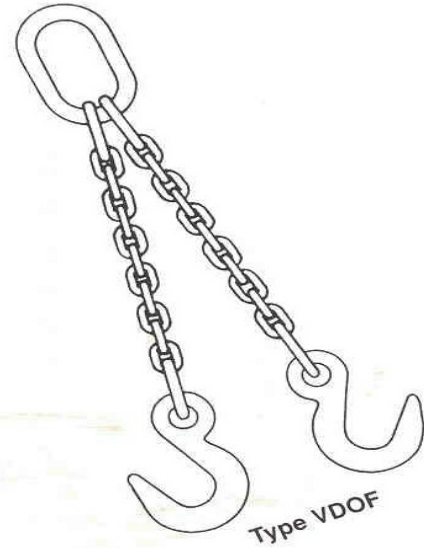
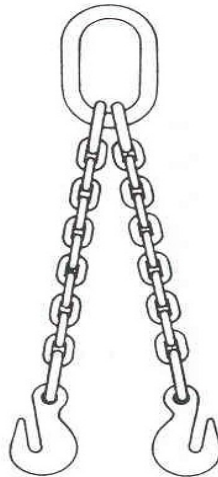
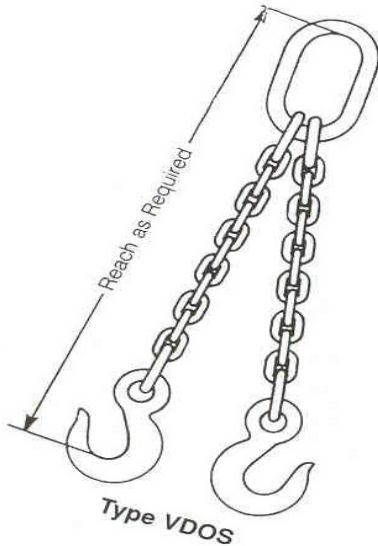

Other configurations available. Ask your sales representative.

Specifications and Working Load Limits

Dimensions are approximate. Double chain slings are available in other combinations.				Working Load Limit*		
				 Pounds	 Pounds	 Pounds
Oblong Master Link, Inches						
Chain Size Inches	Nominal Size Material	Inside Width	Inside Lgth.			
9/32	1/2	2-1/2	5	6100	4900	3500
3/8	3/4	3	6	12300	10000	7100
1/2	1	4	8	20800	17000	12000
5/8	1-1/4	5	10	31300	25600	18100
3/4	1-1/2	6	12	49000	40000	28300
7/8	1-3/4	6	12	59200	48400	34200
1	2	7	14	82600	67400	47700
1-1/4	2-1/4	8	16	125200	102200	72300

Important Terms

Working Load Limit. This is the maximum load in pounds which should be applied to the chain in service. MANUFACTURER DOES NOT ACCEPT ANY LIABILITY FOR DAMAGES WHICH MAY RESULT FROM CHAIN USED IN EXCESS OF THE WORKING LOAD LIMIT.

Proof Test. A term designating a quality control tensile test applied to the chain during or subsequent to the process

of manufacture. It is the minimum force in pounds which the chain has withstood IN THE CONDITION AT THE TIME IT LEFT THE FACTORY, under a test in which a constantly increasing force has been applied in direct tension to a straight length of chain on a standard testing machine.

⚠ WARNING

To prevent the possibility of serious bodily injury:

- **DO NOT EXCEED** the working load limits for chain or components.
- **DO NOT USE** if the chain or components are visibly distorted or worn.

CHAIN SLINGS

CHAIN SLINGS

TRIPLE TYPE: VT

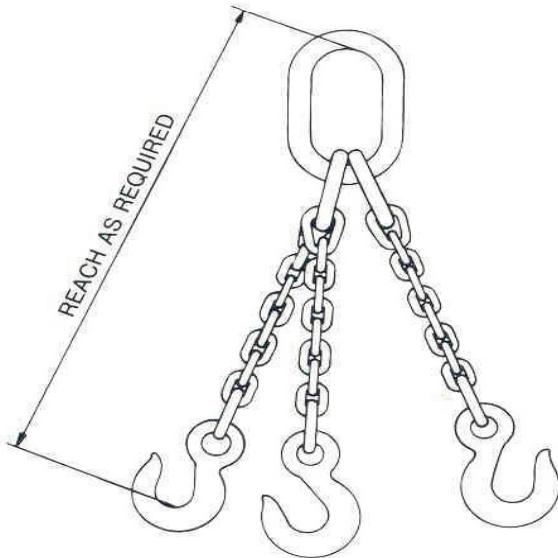

Type VTOS

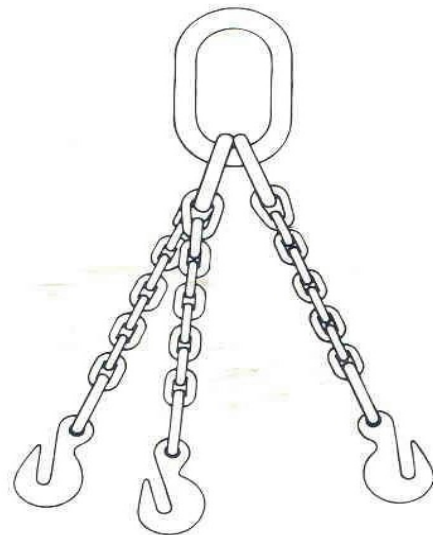

Type VTOG

Other configurations available. Ask your sales representative.

Specifications and Working Load Limits

Dimensions are approximate. Triple chain slings are available in other combinations.				Working Load Limit*		
				 Triple at 60°	 Triple at 45°	 Triple at 30°
Oblong Master Link, Inches				Pounds	Pounds	Pounds
Chain Size Inches	Nominal Size Material	Inside Width	Inside Lgth.			
9/32	3/4	3	6	9100	7400	5200
3/8	1	4	8	18400	15100	10600
1/2	1-1/4	5	10	31200	25500	18000
5/8	1-1/2	6	12	47000	38400	27100
3/4	1-3/4	6	12	73500	60000	42400
7/8	2	7	14	88900	72500	51300
1	2-1/4	8	16	123900	101200	71500
1-1/4	2-3/4	9	16	187800	153400	108400

WARNING

- To prevent the possibility of serious bodily injury:
- **DO NOT EXCEED** the working load limits for chain or components.
 - **DO NOT USE** if the chain or components are visibly distorted or worn.

CHAIN SLINGS

CHAIN SLINGS

QUADRUPLE TYPE: VQ

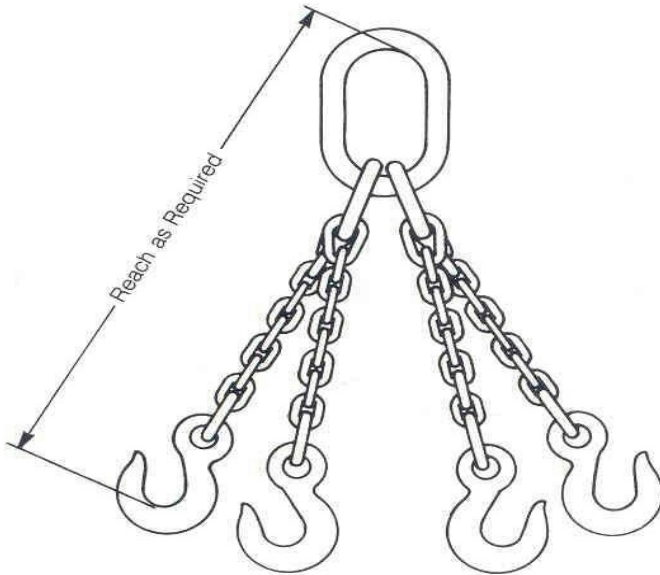

Type VQOS

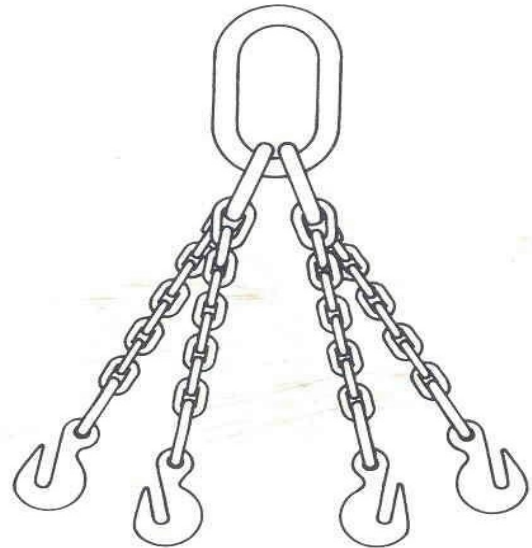

Type VQOG

Other configurations available. Ask your sales representative.

Specifications and Working Load Limits

Oblong Master Link, Inches				Working Load Limit*		
				Quad at 60°	Quad at 45°	Quad at 30°
Chain Size Inches	Nominal Size Material	Inside Width	Inside Lgth.	Pounds	Pounds	Pounds
9/32	3/4	3	6	9100	7400	5200
3/8	1	4	8	18400	15100	10600
1/2	1-1/4	5	10	31200	25500	18000
5/8	1-1/2	6	12	47000	38400	27100
3/4	1-3/4	6	12	73500	60000	42400
7/8	2	7	14	88900	72500	51300
1	2-1/4	8	16	123900	101200	71500
1-1/4	2-3/4	9	16	187800	153400	108400

* NOTE: In practice hooks on "Q" slings are in the plane opposite that shown.

⚠ WARNING

To prevent the possibility of serious bodily injury:

- **DO NOT EXCEED** the working load limits for chain or components.
- **DO NOT USE** if the chain or components are visibly distorted or worn.

CHAIN

TIE-DOWN CHAIN (INTERNATIONAL)



SIZE	FINISH	WEIGHT	UNIT	DRUM QTY	WORKING LOAD LIMIT	STOCK NO.
1/4" X 12'	HIGH TEST SELF COLORED	9.00 LBS	EA	20	2,600 LBS	141102
5/16" X 16'	HIGH TEST SELF COLORED	19.00 LBS	EA	20	3,900 LBS	141109
5/16" X 20'	HIGH TEST SELF COLORED	23.00 LBS	EA	25	3,900 LBS	141110
5/16" X 20'	G70 GOLD PLATED	23.00 LBS	EA	25	4,700 LBS	141610
5/16" X 25'	G70 GOLD PLATED	26.40 LBS	EA	20	4,700 LBS	141611
3/8" X 20'	HIGH TEST SELF COLORED	34.0 LBS	EA	20	5,400 LBS	141112
3/8" X 20'	G70 GOLD PLATED	34.0 LBS	EA	20	6,600 LBS	141612
3/8" X 25'	G70 GOLD PLATED	36.3 LBS	EA	15	6,600 LBS	141615
1/2" X 20'	HIGH TEST SELF COLORED	54.0 LBS	EA	10		141116
1/2" X 20'	G70 GOLD PLATED	54.0 LBS	EA	10	11,300 LBS	141516

NOTE: CLEVIS GRAB HOOKS ONLY

TIE-DOWN CHAIN (DOMESTIC)



SIZE	FINISH	WEIGHT	UNIT	DRUM QTY	WORKING LOAD LIMIT	STOCK NO.
5/16" X 20'	G70 GOLD CHROMATE	23.00 LBS	EA	25	4,700 LBS	141510C
5/16" X 25'	G70 GOLD CHROMATE	28.00 LBS	EA	20	4,700 LBS	141611C
3/8" X 20'	G70 GOLD CHROMATE	34.00 LBS	EA	20	6,600 LBS	141512C
3/8" X 20'	ALLOY- SELF COLORED	30.00 LBS	EA	20	7,100 LBS	141812C
3/8" X 25'	G70 GOLD CHROMATE	40.00 LBS	EA	15	6,600 LBS	141712C
1/2" X 20'	G70 GOLD CHROMATE	54.00 LBS	EA	10	11,300 LBS	141516C

NOTE: CLEVIS GRAB HOOKS ONLY

⚠ WARNING

To prevent the possibility of serious bodily injury:

- DO NOT EXCEED the working load limits for chain or components.
- DO NOT USE for overhead lifting or hoisting.
- DO NOT USE if the chain or components are visibly distorted or worn.

CHAIN

BOOMER CHAIN (DOMESTIC)



SIZE	FINISH	WEIGHT	UNIT	DRUM QTY	WORKING LOAD LIMIT	STOCK NO.
5/16" X 20'	HIGH TEST	25.0 LBS	EA	25 EA	3,900 LBS	141010C
3/8" X 20'	HIGH TEST	34.0 LBS	EA	25 EA	5,400 LBS	141012C
1/2" X 20'	HIGH TEST	54.0 LBS	EA	10 EA	9,200 LBS	141016C

TAIL CHAIN



SIZE	DESCRIPTION	WEIGHT	UNIT	WORKING LOAD LIMIT	STOCK NO.
5/16" - 3/8"	TAIL CHAIN	3.00 LBS	EA	5,400 LBS	146510
1/2" - 5/8"	TAIL CHAIN	5.00 LBS	EA	13,000 LBS	146516
3/4" - 7/8"	TAIL CHAIN	18.20 LBS	EA	34,200 lbs	146524
1" - 1 1/8"	TAIL CHAIN 18"	21.2 LBS	EA	47,700 LBS	146532
1" - 1 1/8"	TAIL CHAIN 24"	23.30 LBS	EA	47,700 LBS	146540

BARGE CHAIN



SIZE	DESCRIPTION	INNER LENGTH (IN)	INNER WIDTH (IN)	WEIGHT	UNIT	WORKING LOAD LIMIT	STOCK NO.
1"	BLACK	5"	2"	20.0LBS/FT	FT	80,000 LBS	

DOCK FENDER CHAIN

GRADE 30, PROOF COIL, HOT DIPPED GALVANIZED

TYPICAL LINK



SIZE	WEIGHT (PER FT)	UNIT	WORKING LOAD LIMIT	STOCK NO.
3/8"		FT		48-0012
1/2"	2.05 LBS	FT	7,500 LBS	48-0016
5/8"	3.20 LBS	FT	17,500 LBS	48-0020
3/4"	4.46 LBS	FT	27,500 LBS	48-0024
1"	8.14 LBS	FT	50,000 LBS	48-0032

WARNING

To prevent the possibility of serious bodily injury:

- **DO NOT EXCEED** the working load limits for chain or components.
- **DO NOT USE** for overhead lifting or hoisting.
- **DO NOT USE** if the chain or components are visibly distorted or worn.

CHAIN BINDERS

LEVER LOAD BINDER (INTERNATIONAL)



SIZE	WEIGHT	UNIT	WORKING LOAD LIMIT	CASE PKG	STOCK NO.
1/4"	3.00 LBS	EA	2,600 LBS	10	142008
5/16" - 3/8"	7.00 LBS	EA	5,400 LBS	5	142010
3/8" - 1/2"	10.00 LBS	EA	9,200 LBS	4	142012

LEVER LOAD BINDER (CROSBY)



SIZE	PART NO.	WEIGHT	UNIT	WORKING LOAD LIMIT	CASE PKG	STOCK NO.
5/16" - 3/8"	BINDER7-1	7.00 LBS	EA	5,400 LBS	4	142010C
3/8" - 1/2"	BINDER A-1	12.50 LBS	EA	9,200 LBS	4	142012C
1/2" - 5/8"	BINDER C-11	19.70 LBS	EA	13,000 LBS	4	142016C

LEVER LOAD BINDER (DOMESTIC)



SIZE	WEIGHT	UNIT	WORKING LOAD LIMIT	CASE PKG	STOCK NO.
5/16" - 3/8"	7.30 LBS	EA	5,400 LBS	4	142010M
3/8" - 7/16"	15.00 LBS	EA	9,200 LBS	4	142014M
3/8" - 1/2"	12.50 LBS	EA	9,200 LBS	4	142012M

WARNING

To prevent the possibility of serious bodily injury:
 • **DO NOT EXCEED** the working load limits

CHAIN BINDERS

RATCHET LOAD BINDER (INTERNATIONAL)



SIZE	WEIGHT	UNIT	WORKING LOAD LIMIT	CASE PKG	STOCK NO.
1/4"	3.50 LBS	EA	2,600 LBS	10	142508
5/16" - 3/8"	11.20 LBS	EA	5,400 LBS	5	142510
3/8" - 1/2"	12.80 LBS	EA	9,200 LBS	5	142512
1/2" - 5/8"	14.60 LBS	EA	13,000 LBS	4	142516

RATCHET LOAD BINDER (CROSBY)

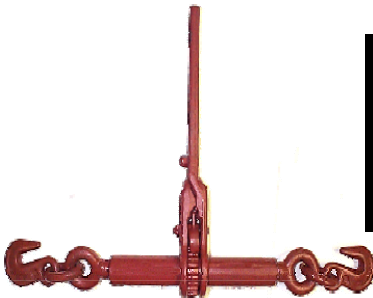

SIZE	DESCRIPTION	WEIGHT	UNT	CASE PKG	WORKINGLOAD LIMIT	STOCKNO
5/16" - 3/8"	BIDERR7	11.23LBS	EA	1	6,600 LBS	142510C
3/8" - 1/2"	BIDERRA	12.83LBS	EA	1	9,200 LBS	142512C
1/2" - 5/8"	BIDERRC	14.55LBS	EA	1	16,000 LBS	142516C

RATCHET LOAD BINDER (DOMESTIC)

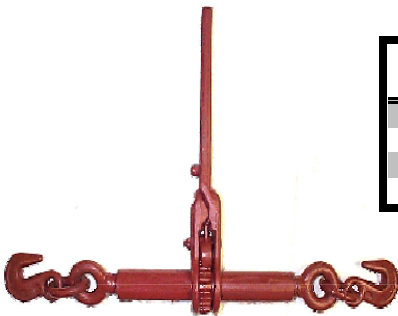

SIZE	WEIGHT	UNIT	WORKING LOAD LIMIT	CASE PKG	STOCK NO.
1/4"	3.00 LBS	EA	2,600 LBS	4	142508M
5/16" - 3/8"	12.25 LBS	EA	5,400 LBS	4	142510M
3/8" - 1/2"	12.25 LBS	EA	9,200 LBS	4	142512M
1/2" - 5/8"	14.00 LBS	EA	13,000 LBS	4	142516M

WARNING

To prevent the possibility of serious bodily injury:
 • **DO NOT EXCEED** the working load limits

CHAIN

DOUBLE LOOP CHAIN (ELECTRO GALV.)



SIZE	WEIGHT	UNIT	CASE PKG	WORKING LOAD LIMIT	STOCK NO.
#4	0.05 LBS	FT	100'	70 LBS	291574
#3	0.06 LBS	FT	100'	90 LBS	291573
#2	0.08 LBS	FT	100'	115 LBS	291572
#1	0.10 LBS	FT	100'	155 LBS	291571
1/O	0.13 LBS	FT	100'	200 LBS	291518
2/O	0.17 LBS	FT	250'	255 LBS	291528
4/O	0.25 LBS	FT	100'	365 LBS	291547

SPECIAL WELL CHAIN (ELECTRIC ZINC PLATED) DOUBLE LOOP, KNOTTED @ CENTER, LOW CARBON STEEL



SIZE	MATERIAL DIAMETER	INSIDE LENGTH	LINKS PER FOOT	WEIGHT PER FOOT	UNIT	CASE PKG	WORKING LOAD LIMIT	STOCK NO.
2/O	.135"	2.17"	5.5	0.16 LBS	FT	250'	255 LBS	291527

LOCK LINK CHAIN (ELECTRO GALV.) SINGLE LOOP



SIZE	DESCRIPTION	WEIGHT	UNIT	CASE PKG	WORKING LOAD LIMIT	STOCK NO.
2/O	LOCK LINK	0.23 LBS	FT	100'	340 LBS	292527
3/O	LOCK LINK	0.26 LBS	FT	100'	405 LBS	292537
4/O	LOCK LINK	0.29 LBS	FT	100'	485 LBS	292547
5/O	LOCK LINK	0.34 LBS	FT	100'	580 LBS	292557

HEEL COIL CHAIN



SIZE	DESCRIPTION	WEIGHT	UNIT	CASE PKG	WORKING LOAD LIMIT	STOCK NO.
5/16"	HEEL COIL CHAIN #130	0.78 LBS	FT	100'	1,350 LBS	292010
5/16"	HEEL COIL CHAIN #131	0.73 LBS	FT	100'	1,200 LBS	292011

WARNING

To prevent the possibility of serious bodily injury:

- DO NOT EXCEED the working load limits for chain or components.
- DO NOT USE for overhead lifting or hoisting.
- DO NOT USE if the chain or components are visibly distorted or worn.

CHAIN

PLASTIC CHAIN



SIZE	COLOR	WEIGHT	UNIT	CASE PKG	TENSILE STRENGTH	STOCK NO.
1 1/2" - 1/4"	YELLOW	.028 LBS	FT	500'	125 LBS	299008
2" - 5/16"	BLACK	.056 LBS	FT	500'	175 LBS	299009
2" - 5/16"	GREEN	.056 LBS	FT	500'	175 LBS	299011
2" - 5/16"	YELLOW	.056 LBS	FT	500'	175 LBS	299012
3" - 3/8"	YELLOW	.16 LBS	FT	300'	300 LBS	299013

PLASTIC CHAIN ACCESSORIES



SIZE	DESCRIPTION	WEIGHT	UNIT	CASE PKG	STOCK NO.
1 1/2" - 1/4"	YELLOW "S" HOOK	0.50 LBS	EA	100	299098
2" - 5/16"	YELLOW REPAIR LINK	0.50 LBS	EA	25	299103
2" - 5/16"	YELLOW "S" HOOK	0.50 LBS	EA	25	299102
1 1/2" - 1/4"	YELLOW REPAIR LINK	0.30 LBS	EA	50	299100
2"-3"	YELLOW SNAP HOOK	0.05 LBS	EA	25	299101
2"	YELLOW QUICK LINK	0.01 LBS	EA	25	299105

PLUMBERS CHAIN



SIZE	FINISH	WEIGHT	UNIT	CASE PKG	WORKING LOAD LIMIT	STOCK NO.
1/0	BRASS	0.03 LBS	FT	100'	35 LBS	291016

WARNING

To prevent the possibility of serious bodily injury:

- **DO NOT EXCEED** the working load limits for chain or components.
- **DO NOT USE** for overhead lifting or hoisting.
- **DO NOT USE** if the chain or components are visibly distorted or worn.

CHAIN

SASH CHAIN



SIZE	FINISH	WEIGHT	UNIT	CASE PKG	WORKING LOAD LIMIT	STOCK NO.
#8	COPPER PLATED	0.04 LBS	FT	100'	68 LBS	295003
#30	COPPER PLATED	0.05 LBS	FT	100'	75 LBS	295032
#35	COPPER PLATED	0.07 LBS	FT	100'	100 LBS	295035
#40	COPPER PLATED	0.07 LBS	FT	100'	131 LBS	295042
#45	COPPER PLATED	0.09 LBS	FT	100'	175 LBS	295045
#50	COPPER PLATED	0.11 LBS	FT	100'	225 LBS	295052
#65	COPPER PLATED	0.20 LBS	FT	100'	315 LBS	295065

SINGLE JACK CHAIN (ELECTRO GALV.)



SIZE	DESCRIPTION	WEIGHT	UNIT	CASE PKG	WORKING LOAD LIMIT	STOCK NO.
#8	SINGLE JACK STEEL	0.21 LBS	FT	100'	60 LBS	294008
#10	SINGLE JACK STEEL	0.14 LBS	FT	100'	34 LBS	294010
#12	SINGLE JACK STEEL	0.08 LBS	FT	100'	29 LBS	294012
#14	SINGLE JACK STEEL	0.04 LBS	FT	100'	16 LBS	294014
#16	SINGLE JACK STEEL	0.03 LBS	FT	100'	8 LBS	294016

STRAIGHT LINK MACHINE CHAIN (ELECTRO GALV.)



SIZE	FINISH	WEIGHT	UNIT	CASE PKG	WORKING LOAD LIMIT	STOCK NO.
3/0.	MACHINED	0.31 LBS	FT	100'	605 LBS	296036
#1	MACHINED	0.19 LBS	FT	100'	370 LBS	296061
#2	MACHINED	0.15 LBS	FT	100'	310 LBS	296072
#3	MACHINED	0.13 LBS	FT	100'	255 LBS	296073
#4	MACHINED	0.10 LBS	FT	100'	205 LBS	296074

⚠ WARNING

To prevent the possibility of serious bodily injury:

- DO NOT EXCEED the working load limits for chain or components.
- DO NOT USE for overhead lifting or hoisting.
- DO NOT USE if the chain or components are visibly distorted or worn.

CHAIN

TWIST LINK MACHINE CHAIN (ELECTRO GALV.)



SIZE	WEIGHT	UNIT	CASE PKG	WORKING LOAD LIMIT	STOCK NO.
1/0.	0.29 LBS	FT	100'	415 LBS	297017
2/0.	0.33 LBS	FT	100'	495 LBS	297027
4/0.	0.45 LBS	FT	100'	635 LBS	297047
#2	0.21 LBS	FT	100'	295 LBS	297072
#4	0.10 LBS	FT	100'	195 LBS	297074



TRAILER SAFETY CHAINS WITH "S" HOOKS-ELECTRO ZINC PLATED



SIZE	CLASS	NUMBER OF HOOKS	HOOK SIZE	WEIGHT	UNIT	DRUM PKG	WORKING LOAD LIMIT	STOCK NO.
3/16" X 4'	I	2	3/8"	1.95 LBS	EA	250	750 LBS	141171
3/16" X 5'	I	2	3/8"	2.64 LBS	EA	100/200	750 LBS	141172
1/4" X 27"	II	1	7/16"	1.80 LBS	EA	350	1,250 LBS	141183
1/4" X 4'	II	1	7/16"	2.00 LBS	EA	100	1,250 LBS	141185
1/4" X 4'	II	2	7/16"	2.00 LBS	EA	100/150	1,250 LBS	141186
1/4" X 5'	II	2	7/16"	2.00 LBS	EA	150/167	1,250 LBS	141187
1/4" X 54"	II	2	7/16"	2.00 LBS	EA	200	1,250 LBS	141188
5/16" X 4'	III	2	17/32"	5.00 LBS	EA	50/100	1,900 LBS	141191
5/16" X 4'	III	1	17/32"	5.50 LBS	EA	100	1,900 LBS	141193
5/16" X 5'6"	III	2	17/32"	6.00 LBS	EA	50/100	1,900 LBS	141196
3/8" X 5'5"	III	2	17/32"	6.54 LBS	EA	62	1,900 LBS	141204

NOT FOR OVERHEAD LIFTING!!!

NOTE: LENGTH MEASURED BEARING TO BEARING



MINE HANGER CHAIN (PROOF COIL/SELF-COLORED)

SIZE	NUMBER OF HOOKS	HOOK TYPE*	WEIGHT	UNIT	DRUM/PAIL QTY	WORKING LOAD LIMIT	STOCK NO.
1/4"X3'6"	1	EGH	3.41 LBS	EA	40/PL	1,300 LBS	141000
1/4"X8'	NO HOOKS	N/A	5.46 LBS	EA	100/DR	1,300 LBS	141001
1/4"X10'	NO HOOKS	N/A	5.80 LBS	EA	80/DR	1,300 LBS	141002
1/4"X7'	1	CGH	4.44 LBS	EA	20/PL-100/DR	1,300 LBS	141003
1/4"X8'	1	CGH	4.34 LBS	EA	20/PL-100/DR	1,300 LBS	141004
1/4"X4'	1	EGH	4.58 LBS	EA	25/PL	1,300 LBS	141005
1/4"X5'	1	EGH	4.58 LBS	EA	25/PL	1,300 LBS	141006
5/16"X7'	1	CGH	6.90 LBS	EA	15/PL	1,900 LBS	141106
3/8"X10'	NO HOOKS	N/A	14.19 LBS	EA	40/DR	2,650 LBS	141012

*EGH = EYE GRAB HOOK CGH = CLEVIS GRAB HOOK

WARNING

To prevent the possibility of serious bodily injury:

- **DO NOT EXCEED** the working load limits for chain or components.
- **DO NOT USE** for overhead lifting or hoisting.
- **DO NOT USE** if the chain or components are visibly distorted or worn.

LINKS

DOUBLE CLEVIS LINK (INTERNATIONAL)



SIZE	WEIGHT	UNIT	WORKING LOAD LIMIT	STOCK NO.
1/4"	0.40 LBS	EA	2,600 LBS	151508I
5/16"-3/8"	0.81 LBS	EA	5,400 LBS	151510I
7/16"	1.25 LBS	EA	7,000 LBS	151514I
1/2"	1.56 LBS	EA	9,200 LBS	151516I

TWIN CLEVIS LINK



SIZE	WEIGHT	UNIT	WORKING LOAD LIMIT	STOCK NO.
1/4"-5/16"	0.31 LBS	EA	4,700 LBS	152508
3/8"	0.44 LBS	EA	6,600 LBS	152512
7/16"-1/2"	0.97 LBS	EA	11,250 LBS	152516

ALLOY CONNECTING LINK



SIZE	DESCRIPTION	WEIGHT	UNIT	WORKING LOAD LIMIT	STOCK NO.
9/32"	BL COUPLER	0.30 LBS	EA	3,500 LBS	154608
3/8"	BL COUPLER	0.60 LBS	EA	7,100 LBS	154612
1/2"	BL COUPLER	1.40 LBS	EA	12,000 LBS	154616
5/8"	BL COUPLER	2.60 LBS	EA	18,100 LBS	154620
3/4"	BL COUPLER	4.40 LBS	EA	28,300 LBS	154624

ALLOY CONNECTING LINK



SIZE	WEIGHT	UNIT	WORKING LOAD LIMIT	STOCK NO.
7/32"	0.10 LBS	EA	2,100 LBS	154507
1/4"	0.28 LBS	EA	3,500 LBS	154508
5/16"	0.33 LBS	EA	4,500 LBS	154510
3/8"	0.73 LBS	EA	7,100 LBS	154512
1/2"	1.64 LBS	EA	12,000 LBS	154516
5/8"	2.86 LBS	EA	18,100 LBS	154520
3/4"	5.00 LBS	EA	28,300 LBS	154524
7/8"	7.50 LBS	EA	34,200 LBS	154528
1"	11.03 LBS	EA	47,700 LBS	154532
1 1/4"	20.38 LBS	EA	72,300 LBS	154540

WARNING

To prevent the possibility of serious bodily injury:
 * DO NOT EXCEED the working load limits

LINKS

ALLOY CONNECTING LINK (INTERNATIONAL)



SIZE	WEIGHT	UNIT	WORKING LOAD LIMIT	STOCK NO.
1/4"	0.28 LBS	EA	3,500 LBS	154508I
5/16"	0.34 LBS	EA	4,500 LBS	154510I
3/8"	0.75 LBS	EA	7,100 LBS	154512I
1/2"	1.64 LBS	EA	12,000 LBS	154516I
5/8"	2.86 LBS	EA	18,100 LBS	154520I
3/4"	5.00 LBS	EA	28,300 LBS	154524I
7/8"	7.50 LBS	EA	34,200 LBS	154528I
1"	11.03 LBS	EA	47,700 LBS	154532I
1 1/4"	20.38 LBS	EA	72,300 LBS	154540I

WELDLESS END LINK



SIZE	WEIGHT	UNIT	WORKING LOAD LIMIT	STOCK NO.
1/2"	0.50 LBS	EA	6,500 LBS	342016
5/8"	1.00 LBS	EA	9,300 LBS	342020
3/4"	1.51 LBS	EA	14,000 LBS	342024

LAP LINK



SIZE	WEIGHT	UNIT	STOCK NO.
3/16" X 1	0.005 LBS	EA	155506
1/4" X 1 1/4	0.010 LBS	EA	155508
5/16" X 1 1/2	0.019 LBS	EA	155510
3/8" X 1 5/8	0.037 LBS	EA	155512
1/2" X 2 1/2	0.070 LBS	EA	155516

COLD SHUTS (ELECTRO ZINC PLATED)



SIZE	WEIGHT	UNIT	WORKING LOAD LIMIT	STOCK NO.
3/16"	0.03 LBS	EA	525 LBS	153506
1/4"	0.06 LBS	EA	925 LBS	153508
5/16"	0.10 LBS	EA	1,450 LBS	153510
3/8"	0.18 LBS	EA	2,110 LBS	153512
7/16"	0.26 LBS	EA	2,850 LBS	153514
1/2"	0.38 LBS	EA	3,750 LBS	153516
5/8"	0.78 LBS	EA	5,850 LBS	153520
3/4"	1.30 LBS	EA	8,425 LBS	153524
7/8"	2.00 LBS	EA	11,475 LBS	153528
1"	3.25 LBS	EA	15,000 LBS	153532

WARNING

To prevent the possibility of serious bodily injury:
 * DO NOT EXCEED the working load limits

LINKS

ALLOY PEAR SHAPE LINK (DOMESTIC)



SIZE	WEIGHT	UNIT	WORKING LOAD LIMIT	STOCK NO.
1/2"	0.55 LBS	EA	3,800 LBS	343516C
5/8"	1.10 LBS	EA	4,200 LBS	343520C
3/4"	1.76 LBS	EA	7,000 LBS	343524C
7/8"	2.82 LBS	EA	14,500 LBS	343528C
1"	4.22 LBS	EA	18,000 LBS	343532C

CARBON PEAR SHAPE LINK



SIZE	DESCRIPTION	WEIGHT	UNIT	WORKING LOAD LIMIT	STOCK NO.
3/8"	SELF COLORED	0.25 LBS	EA	1,800 LBS	343612
3/8"	HOT DIPPED GALV	0.25 LBS	EA	1,800 LBS	343612G
3/8"	RED COLORED	0.25 LBS	EA	1,800 LBS	343612R
1/2"	SELF COLORED	0.55 LBS	EA	2,900 LBS	343616
1/2"	HOT DIPPED GALV	0.55 LBS	EA	2,900 LBS	343616G
1/2"	RED COLORED	0.55 LBS	EA	2,900 LBS	343616R
5/8"	SELF COLORED	1.10 LBS	EA	4,200 LBS	343620
5/8"	HOT DIPPED GALV	1.10 LBS	EA	4,200 LBS	343620G
5/8"	RED COLORED	1.10 LBS	EA	4,200 LBS	343620R
3/4"	SELF COLORED	1.90 LBS	EA	6,000 LBS	343624
3/4"	HOT DIPPED GALV	1.90 LBS	EA	6,000 LBS	343624G
3/4"	RED COLORED	1.90 LBS	EA	6,000 LBS	343624R
7/8"	SELF COLORED	2.78 LBS	EA	8,300 LBS	343628
7/8"	HOT DIPPED GALV	2.78 LBS	EA	8,300 LBS	343628G
7/8"	RED COLORED	2.78 LBS	EA	8,300 LBS	343628R
1"	SELF COLORED	4.40 LBS	EA	10,800 LBS	343632
1"	RED COLORED	4.40 LBS	EA	10,800 LBS	343632R
1 1/4"	SELF COLORED	8.65 LBS	EA	16,750 LBS	343640
1 1/4"	RED COLORED	8.65 LBS	EA	16,750 LBS	343640R
1 3/8"	SELF COLORED	11.50 LBS	EA	20,500 LBS	343644

CARBON PEAR SHAPE LINK (DOMESTIC)



SIZE	WEIGHT	UNIT	WORKING LOAD LIMIT	STOCK NO.
3/8"	0.25 LBS	EA	1,800 LBS	343612C
1/2"	0.55 LBS	EA	2,900 LBS	343616C
5/8"	1.10 LBS	EA	4,200 LBS	343620C
3/4"	1.90 LBS	EA	6,000 LBS	343624C
7/8"	2.78 LBS	EA	8,300 LBS	343628C
1"	4.40 LBS	EA	10,800 LBS	343632C
1 1/4"	8.65 LBS	EA	16,750 LBS	343640C
1 3/8"	11.50 LBS	EA	20,500 LBS	343644C

MISSING LINK



SIZE	WEIGHT	UNIT	WORKING LOAD LIMIT	STOCK NO.
3/16"	0.04 LBS	EA	800 LBS	157506
1/4"	0.063 LBS	EA	1,300 LBS	157508
5/16"	0.125 LBS	EA	1,900 LBS	157510
3/8"	0.20 LBS	EA	2,650 LBS	157512
7/16"	0.275 LBS	EA	3,700 LBS	157514
1/2"	0.38 LBS	EA	4,500 LBS	157516
5/8"	0.725 LBS	EA	6,900 LBS	157520
3/4"	1.225 LBS	EA	10,600 LBS	157524
7/8"	1.75 LBS	EA	12,800 LBS	157528
1"	2.50 LBS	EA	14,000 LBS	157532
1 1/4"	4.64 LBS	EA	18,000 LBS	157540

WARNING

To prevent the possibility of serious bodily injury:
 • DO NOT EXCEED the working load limits

LINKS

MASTER OBLONG LINK



SIZE	WEIGHT	UNIT	WORKING LOAD LIMIT	STOCK NO.
1/2"	0.82 LBS	EA	7,000 LBS	343016
5/8"	1.52 LBS	EA	9,000 LBS	343020
3/4"	2.08 LBS	EA	12,300 LBS	343024
7/8"	3.40 LBS	EA	8,900 LBS	343028
1"	4.85 LBS	EA	24,360 LBS	343032
1 1/4"	9.57 LBS	EA	36,200 LBS	343040
1 3/8"	10.70 LBS	EA	30,100 LBS	343044
1 1/2"	17.80 LBS	EA	54,300 LBS	343048
1 3/4"	24.50 LBS	EA	84,900 LBS	343056
2"	37.05 LBS	EA	102,600 LBS	343064
2 1/8"	50.00 LBS	EA	80,900 LBS	343068
2 1/4"	54.10 LBS	EA	143,100 LBS	343072
2 1/2"	67.75 LBS	EA	160,000 LBS	343080
2 3/4"	87.70 LBS	EA	216,900 LBS	343088

MASTER OBLONG LINK (CROSBY)



SIZE	WEIGHT	UNIT	WORKING LOAD LIMIT	STOCK NO.
1/2"	0.82 LBS	EA	7,000 LBS	343016C
5/8"	1.52 LBS	EA	9,000 LBS	343020C
3/4"	2.08 LBS	EA	12,300 LBS	343024C
1"	4.85 LBS	EA	24,360 LBS	343032C
1 1/4"	9.57 LBS	EA	36,200 LBS	343040C
1 1/2"	17.80 LBS	EA	54,300 LBS	343048C
1 3/4"	24.50 LBS	EA	84,900 LBS	343056C
2"	37.05 LBS	EA	102,600 LBS	343064C
2 1/4"	54.10 LBS	EA	143,100 LBS	343072C
2 1/2"	67.75 LBS	EA	160,000 LBS	343080C
2 3/4"	87.70 LBS	EA	216,900 LBS	343088C

QUICK LINK

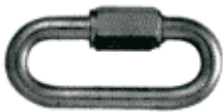

SIZE	WEIGHT	UNIT	WORKING LOAD LIMIT	STOCK NO.
1/8" (3.5MM)	0.02 LBS	EA	220 LBS	652604
3/16" (4MM)	0.05 LBS	EA	616 LBS	652606
7/32" (5MM)	0.08 LBS	EA	720 LBS	652607
1/4" (6MM)	0.12 LBS	EA	880 LBS	652608
5/16" (8MM)	0.18 LBS	EA	1,540 LBS	652610
3/8" (9MM)	0.25 LBS	EA	1,090 LBS	652612
1/2" (12MM)	0.54 LBS	EA	3,300 LBS	652616
5/8" (15MM)	1.33 LBS	EA	6,900 LBS	652620

WARNING

To prevent the possibility of serious bodily injury:
 * **DO NOT EXCEED** the working load limits

LINKS

SPRING LINK



SIZE	WEIGHT	UNIT	STOCK NO.
3/16" (5MM)	0.02 LBS	EA	652506
1/4" (6MM)	0.03 LBS	EA	652508
5/16" (8MM)	0.07 LBS	EA	652510
5/16" (8MM) WIDE MOUTH	0.16 LBS	EA	652510WM
3/8" (10MM)	0.10 LBS	EA	652512
7/16" (11MM)	0.15 LBS	EA	652514
1/2" (12MM)	0.22 LBS	EA	652516
9/16" (14MM)	0.30 LBS	EA	652518

OBLONG SUB ASSEMBLY



SIZE	WEIGHT	UNIT	WORKING LOAD LIMIT	STOCK NO.
3/4"	2.60 LBS	EA	10,500 LBS	343124
7/8"	5.00 LBS	EA	11,200 LBS	343128
1"	6.25 LBS	EA	24,360 LBS	343132
1 1/4"	13.50 LBS	EA	36,000 LBS	343140
1 3/8"	19.00 LBS	EA	37,600 LBS	343144
1 1/2"	23.75 LBS	EA	54,300 LBS	343148
1 3/4"	35.90 LBS	EA	84,900 LBS	343156
2"	57.30 LBS	EA	102,600 LBS	343164

OBLONG SUB ASSEMBLY (CROSBY)



SIZE	WEIGHT	UNIT	WORKING LOAD LIMIT	STOCK NO.
3/4"	2.60 LBS	EA	10,500 LBS	343124C
1"	6.25 LBS	EA	24,360 LBS	343132C
1 1/4"	13.50 LBS	EA	36,000 LBS	343140C
1 1/2"	23.75 LBS	EA	54,300 LBS	343148C
1 3/4"	35.90 LBS	EA	84,900 LBS	343156C
2"	57.30 LBS	EA	102,600 LBS	343164C

GALVANIZED ROUND RING



SIZE	WEIGHT	UNIT	STOCK NO.
1/4" X 2"	0.10 LBS	EA	345008
5/16" X 2.5"	0.20 LBS	EA	345010
3/8" X 3"	0.30 LBS	EA	345012
1/2" X 4"	0.80 LBS	EA	345016
5/8" X 4"	1.34 LBS	EA	345020
5/8" X 5"	1.63 LBS	EA	345020L

TONSBERG MOORING LINK



SIZE	WEIGHT	UNIT	STOCK NO.
90 TON	25.00 LBS	EA	343700

WARNING

To prevent the possibility of serious bodily injury:
 • DO NOT EXCEED the working load limits

VOLMASTER

SYNTHETIC WEB PRODUCTS

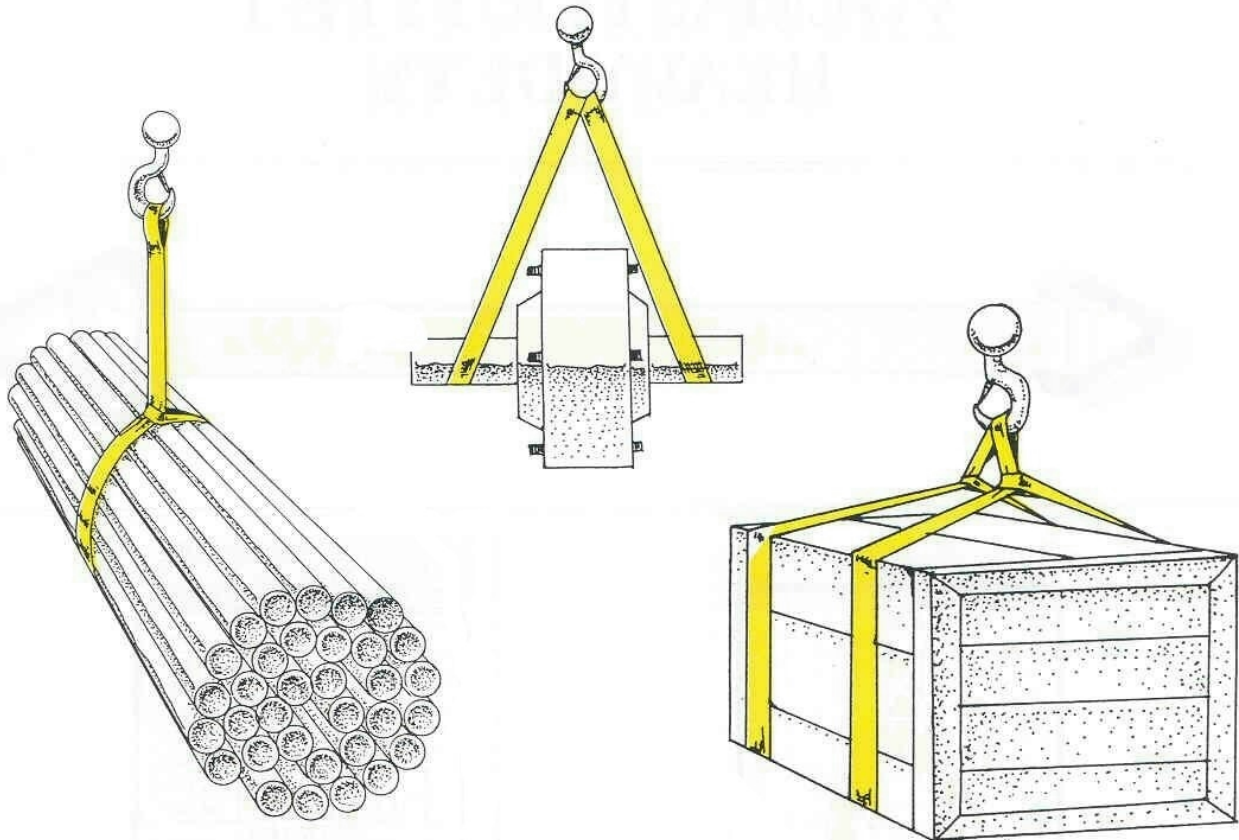

VOLUNTEER WIRE ROPE & SUPPLY CO., INC.

2716 John Deere Drive
Knoxville, TN 37917

PHONE (865)546- 8613 TOLL FREE (800)333-5789 FAX (865)522-6619

www.volwire.com



WEB SLINGS

HOW TO ORDER

DEFINITION OF WEB SLING ORDER CODE

VEE 19 04 15

SLING TYPE (3 LETTERS)

VTC – TYPE 1 – TRIANGLE & CHOKER
VTT – TYPE 2 – TRIANGLE EACH END
VEE – TYPE 3 – EYE & EYE (FLAT EYE STANDARD)
TYPE 4 – EYE & EYE (TWISTED EYE AS OPTION)
VEN – TYPE 5 – ENDLESS
VRE – TYPE 6 – REVERSED EYE
VWL – TYPE 7 – WIDE

NUMBER OF PLYS

1, 2, 3, OR 4

SLING LENGTH

USE ACTUAL PULL TO
PULL LENGTH (REACH IN FT)

SLING WIDTH

ACTUAL WIDTH IN INCHES.
EXCEPTIONS 1 3/4" WIDE SLINGS
WILL BE "30", 3 1/2" WIDE SLINGS
WILL BE "35".

WEB CLASS

6 = VOLMASTER 6000
9 = VOLMASTER 9000

DEFINITION OF WEB SLING ORDER CODE

SPECIFY:

1. SLING TYPE
2. NUMBER OF PLYS
3. WEB CLASS
4. SLING WIDTH IN INCHES
5. SLING LENGTH

WHEN ORDERING SLINGS CONSIDER:

- TYPE OF HITCH
- CAPACITY TABLES
- SLING TO LOAD ANGLES
- ENVIRONMENTAL CONDITIONS

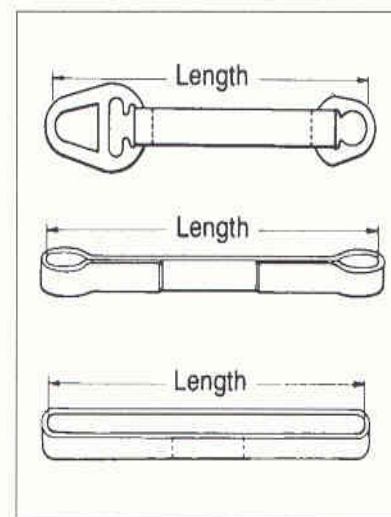

Always measure
sling pull to pull
when flat.

NOTE ON ABRASION TREATMENT

VOLMASTER SLINGS COME WITH AN ABRASION
RESISTANT TREATMENT APPLIED TO THE SLING
WEB.

**CAUTION – DO NOT EXCEED THE MAXIMUM
LOAD/RATED CAPACITIES**

WEB SLINGS

WEB SLINGS

VOLMASTER TYPE 1/VTC HEAVY DUTY

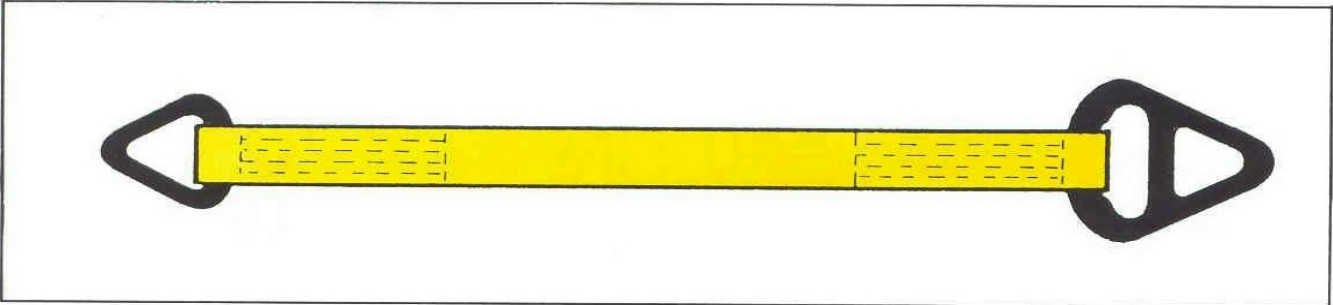

Web Width	RATED CAPACITIES IN LBS.		
	Vertical	Choker	Basket
SINGLE PLY			
2"	3,200	2,400	6,400
3"	4,800	3,600	9,600
4"	6,400	4,800	12,800
5"	8,000	6,000	16,000
6"	9,600	7,200	19,200
8"	12,800	9,600	25,600
10"	16,000	12,000	32,000
12"	19,200	14,400	38,400
TWO PLY			
2"	6,400	4,800	12,800
3"	8,600	6,500	17,200
4"	11,500	8,600	23,000
5"	14,000	10,500	28,000
6"	16,800	12,600	33,600

CHART IS FOR VOLMASTER 9000

TYPE I—Sling made with a triangle fitting on one end and a slotted triangle choker fitting on the other end. It can be used in a vertical, basket or choker hitch.

SLING HITCHES



**CAUTION – DO NOT EXCEED THE MAXIMUM
LOAD/RATED CAPACITIES**

WEB SLINGS

WEB SLINGS

VOLMASTER TYPE 2/VTT HEAVY DUTY

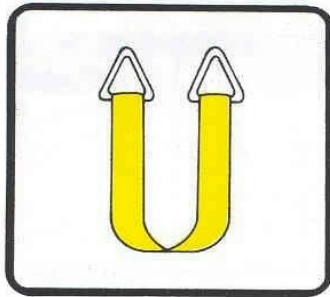
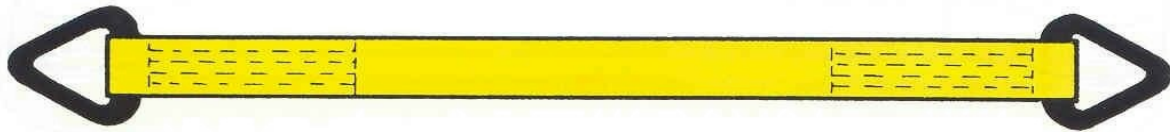

Web Width	RATED CAPACITIES IN LBS.		
	Vertical	Choker	Basket
SINGLE PLY			
2"	3,200		6,400
3"	4,800		9,600
4"	6,400		12,800
5"	8,000		16,000
6"	9,600		19,200
8"	12,800		25,600
10"	16,000		32,000
12"	19,200		38,400
TWO PLY			
2"	6,400		12,800
3"	8,600		17,200
4"	11,500		23,000
5"	14,000		28,000
6"	16,800		33,600

CHART IS FOR VOLMASTER 9000

TYPE II—Sling made with a triangle fitting on both ends. It can be used in a vertical or basket hitch.

NYLON PERFORMANCE CHARACTERISTICS

NYLON is a general purpose synthetic webbing. It is unaffected by grease or oil, and has a good chemical resistance to aldehydes, ethers, and strong alkalis. Nylon should not be exposed to either acids or to bleaching agents. This material should never be exposed to temperatures greater than 200 degrees F. Stretch at rated capacity of a nylon sling will be approximately 6%.

**CAUTION – DO NOT EXCEED THE MAXIMUM
LOAD/RATED CAPACITIES**

WEB SLINGS

WEB SLINGS

VOLMASTER TYPES 3 & 4/VEE HEAVY DUTY

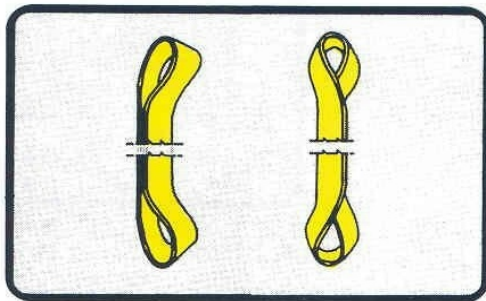
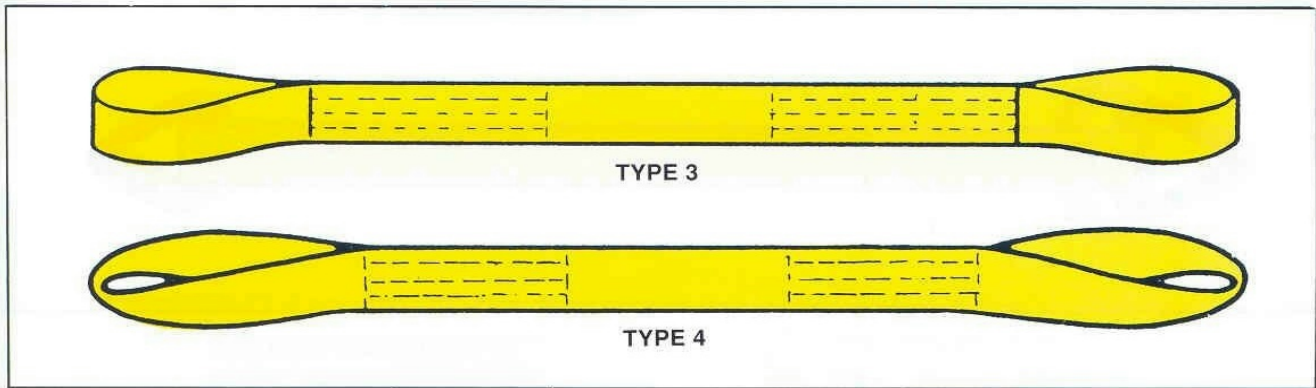

Web Width	RATED CAPACITIES IN LBS.		
	Vertical	Choker	Basket
SINGLE PLY			
1"	1,600	1,200	3,200
2"	3,200	2,400	6,400
3"	4,800	3,600	9,600
4"	6,400	4,800	12,800
5"	8,000	6,000	16,000
6"	9,600	7,200	19,200
TWO PLY			
1"	3,200	2,400	6,400
2"	6,400	4,800	12,800
3"	8,600	6,500	17,200
4"	11,500	8,600	23,000
5"	13,600	10,200	27,200
6"	16,300	12,200	32,600

CHART IS FOR VOLMASTER 9000

TYPE III—Sling made with a flat loop eye on each end with loop eye opening on same plane as sling body. This type of sling is sometimes called a flat eye and eye, eye and eye, or double eye sling.

TYPE IV—Sling made with both loop eyes formed as in Type III, except that the loop eyes are turned to form a loop eye which is at a right angle to the plane of the sling body. This type of sling is commonly referred to as a twisted eye sling.

**CAUTION – DO NOT EXCEED THE MAXIMUM
LOAD/RATED CAPACITIES**

WEB SLINGS

WEB SLINGS

VOLMASTER TYPE 5/VEN HEAVY DUTY

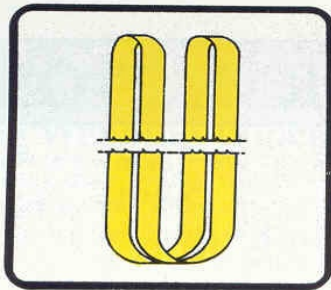
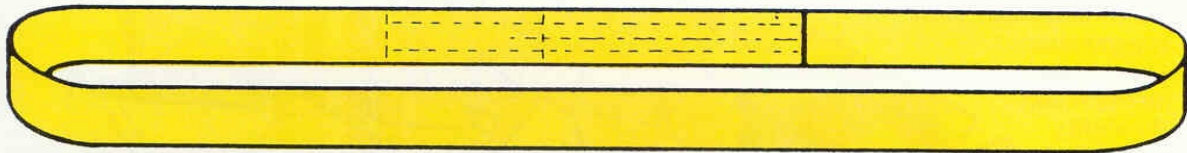

Web Width	RATED CAPACITIES IN LBS.		
	Vertical	Choker	Basket
SINGLE PLY			
1"	3,200	2,500	6,400
2"	6,400	5,000	12,800
3"	8,600	6,900	17,200
4"	11,500	9,200	23,000
5"	13,600	10,900	27,200
6"	16,300	13,000	32,600
TWO PLY			
1"	6,100	4,900	12,200
2"	12,200	9,800	24,400
3"	16,300	13,000	32,600
4"	20,700	16,500	41,400
5"	24,500	19,600	49,000
6"	28,600	23,000	57,200

CHART IS FOR VOLMASTER 9000

TYPE V—Endless sling, sometimes referred to as a grommet. It is a continuous loop formed by joining the ends of the fabric together with a splice.

AS THE ANGLE INCREASES THE SLING CAPACITY DECREASES

Angle (Degrees)	Reduction Factor	Angle (Degrees)	Reduction Factor
0	1.0000	40	0.7660
5	0.9962	45	0.7071
10	0.9848	50	0.6428
15	0.9659	55	0.5736
20	0.9397	60	0.5000
25	0.9083	65	0.4226
30	0.8660	70	0.3420
35	0.8192	75	0.2588

All angles measured from vertical

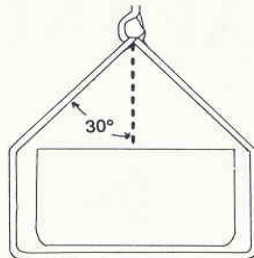





The angle increases of the sling leg reduces its capacity. See chart for reduction factor. Determine the angle between the sling leg and the vertical plane, then multiply the sling rating by the reduction factor from the chart. This will determine the slings reduced capacity.

**CAUTION – DO NOT EXCEED THE MAXIMUM
LOAD/RATED CAPACITIES**

ROUND SLINGS

RATED CAPACITIES (WORKING LOAD LIMITS)



PART NO.	COLOR	APPROX DIAMETER	APPROX WEIGHT/FT*	VERTICAL	CHOKE	VERT BASKET	30 DEGREE BASKET	45 DEGREE BASKET
								
		INCH	LBS/FT	LBS	LBS	LBS	LBS	LBS
VR1	PURPLE	0.60	0.30	2600	2080	5200	4500	3600
VR2	GREEN	0.80	0.40	5300	4240	10600	9100	7400
VR3	YELLOW	1.00	0.50	8400	6720	16800	14500	11800
VR4	TAN	1.20	0.60	10600	8480	21200	18300	15000
VR5	RED	1.30	0.80	13200	10560	26400	22800	18600
VR6	ORANGE	1.40	0.90	15900	12720	31800	27500	22500
VR7	BLUE	1.55	1.20	21200	16960	42400	36700	29900
VR8	ORANGE	1.75	1.50	25000	20000	50000	43300	35300
VR9	ORANGE	1.95	2.00	31000	24800	62000	53600	43800
VR10	ORANGE	2.35	2.80	40000	32000	80000	69200	56500
VR11	ORANGE	3.15	3.60	52900	42320	105800	91600	74800
VR12	ORANGE	3.95	4.60	66100	52880	132200	114400	93400
VR13	ORANGE	4.80	5.80	90000	72000	180000	158000	127200

*PER 2 FT CIRCUMFERENTIAL LENGTH

HOW TO ORDER

1. DETERMINE WORKING LOAD LIMIT NEEDED
2. USING CHART ABOVE, PLEASE PROVIDE PART NUMBER AND DIAMETER.
 - EXAMPLE: FOR A RED 10 FOOT ROUND SLING WITH A 13,200 LB VERTICAL CAPACITY, ORDER: VR5-10

**NEED HELP ORDERING?
GIVE US A CALL AT (800) 333-5789, AND AS ALWAYS, WE ARE READY TO HELP.**

**CAUTION – DO NOT EXCEED THE MAXIMUM
LOAD/RATED CAPACITIES**

WIRE MESH SLINGS

10 GAUGE HEAVY DUTY

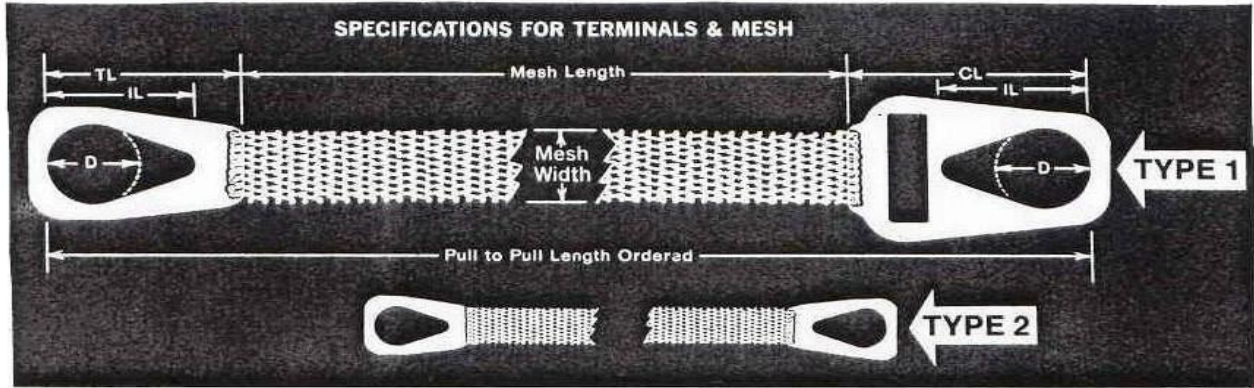

NOMINAL MESH WIDTH	TERMINAL DIMENSIONS				TERMINAL THICKNESS	APPROX. WEIGHT OF 3' TYPE 1 SLING	MESH WEIGHT (PER FT)
MW	D	IL	TL	CL	10 GA	10 GA	10 GA
2"	2"	3"	3 7/8"	5 5/8"	1/2"	6 LBS	1.3 LBS
3"	2 1/4"	3 3/8"	4 3/8"	6 1/4"	1/2"	8 LBS	1.9 LBS
4"	3"	4"	5"	6 3/4"	1/2"	10 LBS	2.5 LBS
6"	3 1/2"	4 1/2"	5 5/8"	7 3/4"	1/2"	14 LBS	3.9 LBS

WIRE MESH WIDTH	RATED CAPACITY			UNIT	STOCK NO. TYPE I
	VERTICAL	CHOKER	VERTICAL BASKET		
2"	2,300 LBS	2,300 LBS	4,600 LBS	EA	403200
3"	3,500 LBS	3,500 LBS	7,000 LBS	EA	403300
4"	4,800 LBS	4,800 LBS	9,600 LBS	EA	403400
6"	7,200 LBS	7,200 LBS	14,400 LBS	EA	403600

NOTE: THE CHOKER FITTING MUST NOT BE POSITIONED AGAINST A LOAD EDGE OR DIRECTLY ON THE TRIANGLE FITTING.

WHEN ORDERING PLEASE STATE WIDTH, LENGTH, AND TYPE.

WE ALSO REPAIR MESH SLINGS!!!

WARNING !

DO NOT EXCEED RATED CAPACITIES. SLING CAPACITY DECREASES AS THE ANGLE FROM HORIZONTAL DECREASES. SLINGS SHOULD NOT BE USED AT ANGLES OF LESS THAN 30 DEGREES.

CARGO CONTROL

WINCH STRAPS

FLAT HOOK



SIZE	WEIGHT	UNIT	WORKING LOAD LIMIT	STOCK NO.
2" X 27'	2.80 LBS	EA	3,335 LBS	144047
2" X 30'	3.10 LBS	EA	3,335 LBS	144050
3" X 27'	3.75 LBS	EA	4,300 LBS	144053
3" X 30'	4.00 LBS	EA	4,300 LBS	144054
4" X 27'	4.25 LBS	EA	5,400 LBS	144057
4" X 30'	4.75 LBS	EA	5,400 LBS	144060



CHAIN END

SIZE	WEIGHT	UNIT	WORKING LOAD LIMIT	STOCK NO.
2" X 27'	5.00 LBS	EA	3,335 LBS	144045
2" X 30'	4.25 LBS	EA	3,335 LBS	144048
3" X 27'	5.60 LBS	EA	4,300 LBS	144051
3" X 30'	5.90 LBS	EA	4,300 LBS	144056
4" X 27'	7.40 LBS	EA	5,400 LBS	144059
4" X 30'	7.80 LBS	EA	5,400 LBS	144062



WIRE HOOK

SIZE	WEIGHT	UNIT	WORKING LOAD LIMIT	STOCK NO.
2" X 27'	2.80 LBS	EA	3,335 LBS	144046
2" X 30'	3.10 LBS	EA	3,335 LBS	144049
3" X 27'	3.75 LBS	EA	4,300 LBS	144052
3" X 30'	4.00 LBS	EA	4,300 LBS	144055
4" X 27'	4.25 LBS	EA	5,400 LBS	144058
4" X 30'	4.75 LBS	EA	5,400 LBS	144061

⚠ WARNING
To prevent the possibility of serious bodily injury: • DO NOT EXCEED the working load limits

CARGO CONTROL

FLAT HOOK RATCHET STRAPS



SIZE*	WEIGHT	UNIT	WORKING LOAD LIMIT	STOCK NO.
2" X 27'	6.50 LBS	EA	3,335 LBS	144027
2" X 30'	6.70 LBS	EA	3,335 LBS	144030
3" X 27'	12.34 LBS	EA	5,400 LBS	144031
3" X 30'	4.00 LBS	EA	4,300 LBS	144055
4" X 27'	14.87 LBS	EA	6,670 LBS	144035

*THE ABOVE ARE STOCKED SIZES, NEED A SPECIAL SIZE?, SEE NEXT PAGE TO ORDER.

CHAIN ANCHOR RATCHET STRAPS

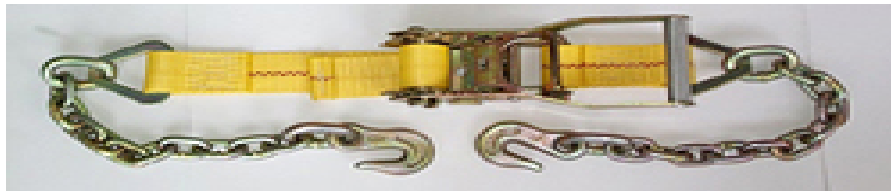

SIZE*	WEIGHT	UNIT	WORKING LOAD LIMIT	STOCK NO.
2" X 30'	15.65 LBS	EA	3,335 LBS	144029

*THE ABOVE ARE STOCKED SIZES, NEED A SPECIAL SIZE?, SEE NEXT PAGE TO ORDER.

WIRE HOOK RATCHET STRAPS



SIZE*	WEIGHT	UNIT	WORKING LOAD LIMIT	STOCK NO.
2" X 27'	6.35 LBS	EA	3,335 LBS	144028

*THE ABOVE ARE STOCKED SIZES, NEED A SPECIAL SIZE?, SEE NEXT PAGE TO ORDER.

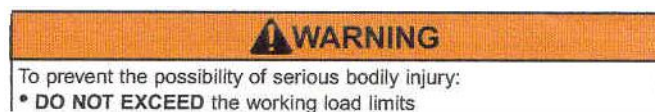

CARGO CONTROL

PORTA-RATCHET ASSEMBLIES

VOLMASTER PORTA-RATCHET STRAPS



Standard porta-ratchet strap is 27'. Other lengths available on request.

NOT TO BE USED FOR OVERHEAD LIFTING.

EASY TO USE

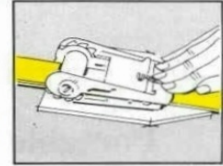
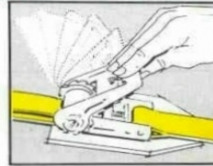
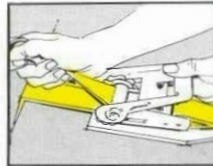
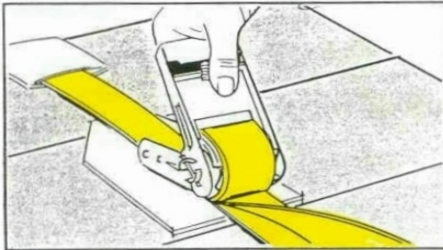

1. Insert end of strap through slot in ratchet reel and pull until snug.

2. Pump handle back and forth to operate ratchet.

3. When straps are tight, put handle down flat to lock and hold the load.

ORDERING INFORMATION

2"x27' Porta Ratchet Assy W/ Flat Hook

CODE	Style Codes WIDTH
PR	1" Porta-Ratchet Strap
PR	2" Porta-Ratchet Strap
PR	3" Porta-Ratchet Strap
CB	2" Cambuckle Strap

CODE	Hardware Codes ITEM
FH	Flat Hook
DR	Delta Ring
SH	Snap Hook
WH	Wire Hook
CA	Chain Anchor
ET	E-Track

EXAMPLE:

PR227FH

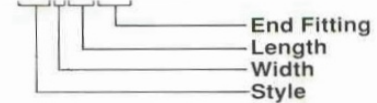



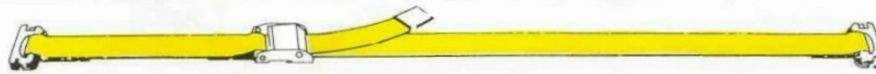



VOLMASTER CAMBUCKLE STRAPS



Standard Cambuckle strap is 27'. Other lengths available on request.

NOT TO BE USED FOR OVERHEAD LIFTING.

END FITTINGS

					
FLAT HOOK	DELTA RING	SNAP HOOK	WIRE HOOK	CHAIN ANCHOR	E-TRACK

WARNING

To prevent the possibility of serious bodily injury:
 • DO NOT EXCEED the working load limits

CARGO CONTROL

CARGO TIE DOWN STRAPS



SIZE	DESCRIPTION	WEIGHT	WORKING LOAD LIMIT	UNIT	STOCK NO.
1" X 6'	CARGO TIE-DOWN W WIRE HOOK	1.40 LBS	1,000 LBS	EA	144073
1" X 10'	CARGO TIE-DOWN W WIRE HOOK	1.52 LBS	1,000 LBS	EA	144074
1" X 12'	CARGO TIE-DOWN W WIRE HOOK	1.53 LBS	1,000 LBS	EA	144075
1" X 15'	CARGO TIE-DOWN W WIRE HOOK	1.54 LBS	1,000 LBS	EA	144076
7/8" X 5 1/2"	TIE-DOWN STRAP W HOOK	0.55 LBS	NA	SET	144006
7/8" X 6'	TIE-DOWN STRAP W HOOK(2PCS)	0.60 LBS	NA	SET	144008
1" X 6'	4 PC LOCKING TIE DOWN SET	2.00 LBS	NA	SET	144018
1" X 15'	CARGO LASHING TIE DOWN	0.46 LBS	NA	EA	144001
1" X 15'	RATCHET CARGO TIE-DOWN	0.55 LBS	NA	EA	144015
1" X 15'	CARGO TIE-DOWN W S HOOK	1.00 LBS	NA	EA	144026
1" X 15'	4 PC LOCKING TIE DOWN SET	1.75 LBS	NA	SET	144010

1" CAMBUCKLE ASSY



1" CAMBUCKLE ASSY

AVAILABLE WITH: FLAT HOOK, D-RING, S-HOOK, COATED S-HOOK, SNAP HOOK, CHAIN ANCHOR

2" CAMBUCLKE ASSY



2" CAMBUCKLE ASSY

AVAILABLE WITH: FLAT HOOK, D-RING, S-HOOK, COATED S-HOOK, SNAP HOOK, CHAIN ANCHOR

⚠ WARNING
To prevent the possibility of serious bodily injury: • DO NOT EXCEED the working load limits

CARGO CONTROL

SPECIAL APPLICATION

Need a special size or design?
We can make it to your exact specifications.

Assorted
Standard Designs

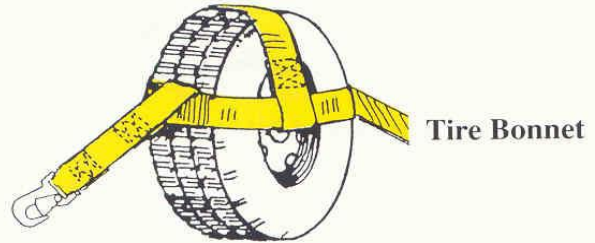
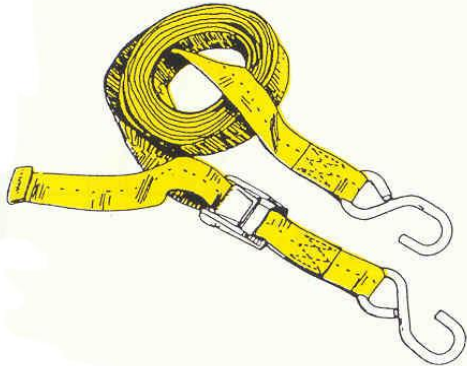
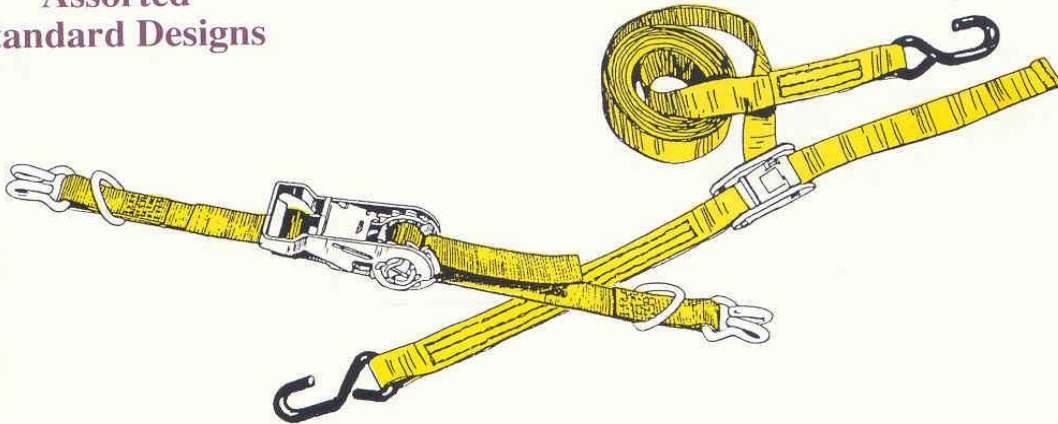

Tire Bonnet

Axle Strap

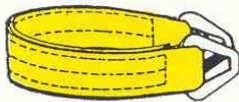

Car Tie-Down

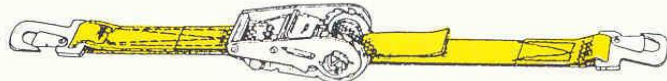

with snap hooks

FOR CARGO RESTRAINT APPLICATION ONLY.

CARGO CONTROL



CHAIN ANCHOR ASSEMBLY

SIZE	DESCRIPTION	WEIGHT	UNIT	WORKING LOAD LIMIT	STOCK NO.
5/16" X 18"	CHAIN END, 5/16", 1/2" RING	3.00 LBS	EA	4,700 LBS	145006
3/8" X 18"	CHAIN END, 3/8", 1/2" RING	3.50 LBS	EA	5,400 LBS	145003



CORNER PROTECTORS

SIZE	MATERIAL	WEIGHT	UNIT	WORKING LOAD LIMIT	STOCK NO.
90 DEG	PLASTIC	0.25 LBS	EA	NOT RATED	145800
2" X 3"	RUBBER	0.25 LBS	EA	NOT RATED	145806

CARGO NET

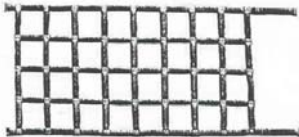

SIZE	DESCRIPTION	WEIGHT	UNIT	STOCK NO.
90" X 90"	CARGO NET	50.00 LBS	EA	145048

BUCKLE

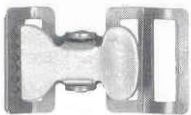















SIZE	DESCRIPTION	WEIGHT	UNIT	WORKING LOAD LIMIT	STOCK NO.
1"	WEB STRAP BUCKLE	0.09 LBS	EA	NOT RATED	145509
1"	CAMBUCKLE 835 LBS	0.44 LBS	EA	835 LBS	145506
1"	CAMBUCKLE 150 LBS	0.38 LBS	EA	150 LBS	145507
2"	CAMBUCKLE 835 LBS	0.56 LBS	EA	835 LBS	145508

⚠ WARNING
To prevent the possibility of serious bodily injury: • DO NOT EXCEED the working load limits

CARGO CONTROL

HOOKS

	SIZE	DESCRIPTION	WEIGHT	UNIT	WORKING LOAD LIMIT	STOCK NO.
	3/8"	GRAB HOOK W/PEAR LINK ASSY	1.36 LBS	EA	5,400 LBS	145002
	2"	NARROW FLAT HOOK	0.40 LBS	EA	1,835 LBS	144110
	2"	FLAT HOOK	0.68 LBS	EA	3,335 LBS	144111
	4"	FLAT HOOK	1.06 LBS	EA	5,400 LBS	144115
	1"	FLAT SNAP HOOK	0.22 LBS	EA	1,835 LBS	144120
	2"	FLAT SIDE SNAP HOOK	0.41 LBS	EA	2,000 LBS	144131
	2"	FLAT SNAP HOOK	0.69 LBS	EA	3,335 LBS	144133
	2"	TWISTED SNAP HOOK	0.61 LBS	EA	3,335 LBS	144136
	1"	NARROW "J" HOOK	0.12 LBS	EA	170 LBS	144150
	1"	WIRE "J" HOOK	0.39 LBS	EA	170 LBS	144151
	2"	WIRE "J" HOOK	0.40 LBS	EA	1,660 LBS	144155
	2"	WIRE "J" HOOK	0.66 LBS	EA	3,335 LBS	144156
	3"	WIRE "J" HOOK	1.50 LBS	EA	6,500 LBS	144157
	N/A	DOUBLE LOCKING LAYNARD HOOK	0.75 LBS	EA	5,000 LBS	144170
	1"	VINYL COATED "S" HOOK, .27	0.14 LBS	EA	170 LBS	144220
	1"	VINYL COATED "S" HOOK, .37	0.31 LBS	EA	400 LBS	144221
	1"	ZP COATED "S" HOOK, .37	0.29 LBS	EA	400 LBS	144225
	1.5 TON	WEB SLING HOOK, VS320A	1.10 LBS	EA	3,000 LBS	144234
	3 TON	WEB SLING HOOK, VS320A	2.86 LBS	EA	6,000 LBS	144237
	2"	WEB SLIDING CHOKER HOOK	1.50 LBS	EA	2,000 LBS	144300
	8"	EYE "J" HOOK HT-ZP	2.25 LBS	EA	3,900 LBS	144306
	15"	TURNED EYE "J" HOOK HT-ZP	3.50 LBS	EA	3,900 LBS	144315
	8"	CLEVIS "J" HOOK HT-ZP	2.05 LBS	EA	3,000 LBS	144305
	15"	CLEVIS "J" HOOK ZP	3.25 LBS	EA	3,000 LBS	144310
	N/A	CLUSTER, R-T-J-TOW HOOK	2.30 LBS	EA	3,900 LBS	144325

WARNING

To prevent the possibility of serious bodily injury:
 • DO NOT EXCEED the working load limits

CARGO CONTROL

RINGS



SIZE	DESCRIPTION	WEIGHT	UNIT	WORKING LOAD LIMIT	STOCK NO.
1 1/2"	DELTA RING, WELDED	0.11 LBS	EA	500 LBS	145302
2"	DELTA RING, FORGED	0.25 LBS	EA	5,000 LBS	145310
2"	DELTA RING WELDED	0.10 LBS	EA	1,670 LBS	145360
2"	DELTA RING FLAT	0.29 LBS	EA	3,335 LBS	145315
2"	DELTA RING SAFETY BELT	0.30 LBS	EA	5,000 LBS	145330
3"	DELTA RING	0.90 LBS	EA	5,400 LBS	145342
4"	DELTA RING	1.25 LBS	EA	6,600 LBS	145343

RATCHETS



SIZE	DESCRIPTION	WEIGHT	UNIT	WORKING LOAD LIMIT	STOCK NO.
1"	WIDE HANDLE	0.74 LBS	EA	1,100 LBS	145500
1"	RATCHET	0.50 LBS	EA	500 LBS	145500.1
2"	WIDE HANDLE	2.46 LBS	EA	3,335 LBS	145501
2"	SHORT HANDLE	2.24 LBS	EA	3,335 LBS	145501.2
3"	WIDE HANDLE	7.05 LBS	EA	5,670 LBS	145504
4"	WIDE HANDLE	7.94 LBS	EA	8,000 LBS	145505

CARGO WINCH TRACK



SIZE	DESCRIPTION	WEIGHT	UNIT	STOCK NO.
1/4" X 6'	STEEL WINCH TRACK	39.00 LBS	EA	146000
1/4" X 10'	"E" WINCH TRACK	65.00 LBS	EA	146001

WINCH TRACK FITTINGS



SIZE	DESCRIPTION	WEIGHT	UNIT	STOCK NO.
2"	"E" TRACK FITTING	0.22 LBS	EA	146051
2"	"F" TRACK FITTING	0.19 LBS	EA	146055

⚠ WARNING
To prevent the possibility of serious bodily injury: • DO NOT EXCEED the working load limits

CARGO CONTROL

CARGO WINCH



DISC WEBBING



WELD ON



LASHING



BOLT ON



STANDARD SLIDING



CABLE WINCH

SIZE	DESCRIPTION	WEIGHT	UNIT	WORKING LOAD LIMIT	STOCK NO.
2"	DISC WEBBING WINCH V-300	10.90 LBS	EA	3,335 LBS	149001
2"	LASHING BOLT ON	3.40 LBS	EA	3,335 LBS	149064
4"	STANDARD WELD ON V-700	8.40 LBS	EA	5,000 LBS	149011
4"	LOW PROFILE WELD ON V-700-LP	7.30 LBS	EA	5,000 LBS	149012
4"	STORABLE WELD ON V-700S	9.60 LBS	EA	5,000 LBS	149013
4"	STANDARD BOLT ON V700P	9.60 LBS	EA	5,000 LBS	149021
4"	STANDARD SLIDING V700S	9.10 LBS	EA	5,000 LBS	149031

CHROME WINCH BARS



SIZE	DESCRIPTION	WEIGHT	UNIT	WORKING LOAD LIMIT	STOCK NO.
24"	WINCH ADJUSTING BAR	4.50 LBS	EA	NOT RATED	140103
24"	ADJUSTING BAR COMBINATION	6.00 LBS	EA	NOT RATED	140104

⚠ WARNING

To prevent the possibility of serious bodily injury:
 • DO NOT EXCEED the working load limits

HOISTS

HOISTS

AND ACCESSORIES

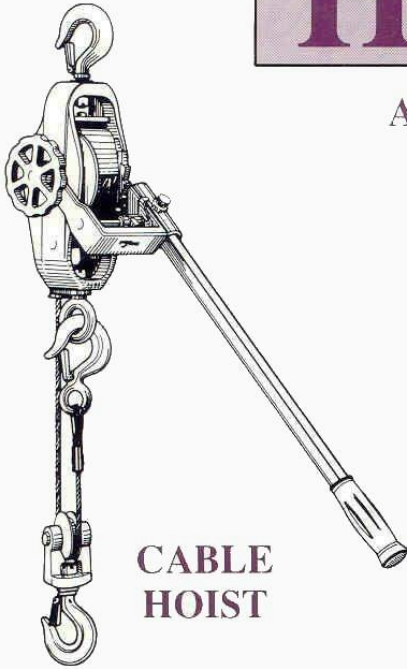

**CABLE
HOIST**

BEAM CLAMP

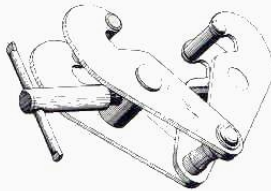

**CAPACITY
2000 LBS-20000 LBS.**

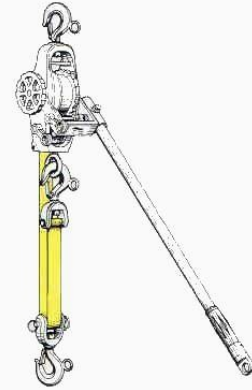

**NYLON WEB
HOIST**

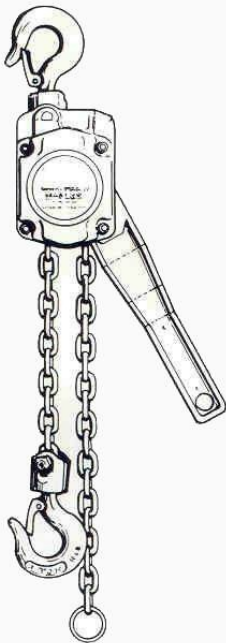

**RATCHET
LEVER HOIST**

TROLLEYS

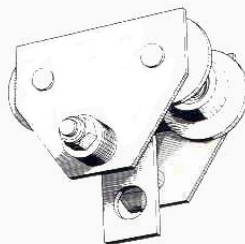

**PLAIN or GEARED
CAPACITY
½ TON - 16 TON**



**ELECTRIC
CHAIN HOIST**

HOISTS

LEVER OPERATED CHAIN HOIST (PREMIER – INTERNATIONAL)



SIZE	TYPE	FALL	WEIGHT	UNIT	WORKING LOAD LIMIT	STOCK NO.
3/4 TON	V LEVER	5 FT	19.0 LBS	EA	3/4 TON	303320.05
3/4 TON	V LEVER	10 FT	21.0 LBS	EA	3/4 TON	303320.10
3/4 TON	V LEVER	15 FT	26.0 LBS	EA	3/4 TON	303320.15
3/4 TON	V LEVER	20 FT	28.0 LBS	EA	3/4 TON	303320.20
1 1/2 TON	V LEVER	5 FT	27.0 LBS	EA	1 1/2 TON	303340.05
1 1/2 TON	V LEVER	10 FT	32.0 LBS	EA	1 1/2 TON	303340.10
1 1/2 TON	V LEVER	15 FT	37.0 LBS	EA	1 1/2 TON	303340.15
1 1/2 TON	V LEVER	20 FT	41.0 LBS	EA	1 1/2 TON	303340.20
3 TON	V LEVER	5 FT	45.0 LBS	EA	3 TON	303360.05
3 TON	V LEVER	10 FT	51.0 LBS	EA	3 TON	303360.10
3 TON	V LEVER	20 FT	75.0 LBS	EA	3 TON	303360.20

LEVER OPERATED CHAIN HOIST (CM 653 SERIES)



SIZE	FALL	WEIGHT	UNIT	WORKING LOAD LIMIT	STOCK NO.
3/4 TON	5 FT	19.0 LBS	EA	3/4 TON	312320.05
3/4 TON	10 FT	21.0 LBS	EA	3/4 TON	312320.10
3/4 TON	15 FT	26.0 LBS	EA	3/4 TON	312320.15
3/4 TON	20 FT	28.0 LBS	EA	3/4 TON	312320.20
1 1/2 TON	5 FT	31.0 LBS	EA	1 1/2 TON	312340.05
1 1/2 TON	10 FT	36.0 LBS	EA	1 1/2 TON	312340.10
1 1/2 TON	15 FT	41.0 LBS	EA	1 1/2 TON	312340.15
1 1/2 TON	20 FT	45.0 LBS	EA	1 1/2 TON	312340.20
3 TON	5 FT	51.0 LBS	EA	3 TON	312360.05
3 TON	10 FT	59.0 LBS	EA	3 TON	312360.10
3 TON	20 FT	67.0 LBS	EA	3 TON	312360.20

WARNING

To prevent the possibility of serious bodily injury:
• **DO NOT EXCEED** the working load limits

HOISTS

CHAIN HAND HOIST (PREMIER INTERNATIONAL)

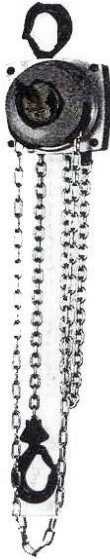

SIZE	FALL	WEIGHT	UNIT	WORKING LOAD LIMIT	STOCK NO.
1/4 TON	5 FT	32.0 LBS	EA	1/4 TON	3031105.05
1/4 TON	10 FT	32.0 LBS	EA	1/4 TON	3031105.10
1/2 TON	8 FT	15.0 LBS	EA	1/2 TON	303110.08
1/2 TON	15 FT	25.0 LBS	EA	1/2 TON	303110.15
1/2 TON	20 FT	30.0 LBS	EA	1/2 TON	303110.20
1/2 TON	30 FT	38.0 LBS	EA	1/2 TON	303110.30
1 TON	8 FT	25.0 LBS	EA	1 TON	3031130.08
1 TON	15 FT	32.00 LBS	EA	1 TON	3031130.15
1 TON	20 FT	38.0 LBS	EA	1 TON	3031130.20
1 TON	30 FT	48.0 LBS	EA	1 TON	3031130.30
2 TON	8 FT	57.0 LBS	EA	2 TON	3031150.08
2 TON	10 FT	61.0 LBS	EA	2 TON	3031150.10
2 TON	20 FT	80.0 LBS	EA	2 TON	3031150.20
3 TON	10 FT	87.0 LBS	EA	3 TON	3031160.10
3 TON	20 FT	109.0 LBS	EA	3 TON	3031160.20
5 TON	20 FT	123.00 LBS	EA	5 TON	3031170.20
10 TON	30 FT	181.5 LBS	EA	10 TON	3031190.30

CHAIN HAND HOIST (CM 622 SERIES)



SIZE	FALL	WEIGHT	UNIT	WORKING LOAD LIMIT	STOCK NO.
1/2 TON	8 FT	15.0 LBS	EA	1/2 TON	311110.08
1/2 TON	12 FT	22.0 LBS	EA	1/2 TON	311110.12
1/2 TON	20 FT	30.0 LBS	EA	1/2 TON	311110.20
1 TON	8 FT	22.0 LBS	EA	1 TON	311130.08
1 TON	12 FT	29.0 LBS	EA	1 TON	311130.12
1 TON	20 FT	38.0 LBS	EA	1 TON	311130.20
1 TON	30 FT	48.0 LBS	EA	1 TON	311130.30
2 TON	8 FT	44.0 LBS	EA	2 TON	311150.08
2 TON	12 FT	65.0 LBS	EA	2 TON	311150.12
2 TON	15 FT	72.0 LBS	EA	2 TON	311150.15
2 TON	20 FT	80.0 LBS	EA	2 TON	311150.20
2 TON	30 FT	98.0 LBS	EA	2 TON	311150.30
3 TON	8 FT	85.0 LBS	EA	3 TON	311160.08
3 TON	20 FT	109.0 LBS	EA	3 TON	311160.20
5 TON	20 FT	123.0 LBS	EA	5 TON	311170.20
10 TON	8 FT	164.0 LBS	EA	10 TON	311190.08

WARNING

To prevent the possibility of serious bodily injury:
 • **DO NOT EXCEED** the working load limits

HOISTS

CABLE HOIST (COMALONG) (DOMESTIC-ALUM HOUSING)



SIZE	LIFT	WEIGHT	UNIT	WORKING LOAD LIMIT	STOCK NO.
1/2 TON	15 FT	7.00 LBS	EA	1/2 TON	305610.15
1 1/8 TON	38 FT	7.00 LBS	EA	1 1/8 TON	305622.38
1 1/2 TON	10 FT	14.00 LBS	EA	1 1/2 TON	305630.10
1 1/2 TON	30 FT	15.00 LBS	EA	1 1/2 TON	305630.30
2 TON	20 FT	16.00 LBS	EA	2 TON	305640.20
3 TON	15 FT	34.00 LBS	EA	3 TON	305660.15



CABLE HOIST (CABLE PULLER) (INTERNATIONAL)

SIZE	WEIGHT	UNIT	WORKING LOAD LIMIT	STOCK NO.
2 TON	10.0 LBS	EA	2 TON	305450
4 TON	12.0 LBS	EA	4 TON	305460

ELECTRIC WIRE ROPE HOIST (DOMESTIC)

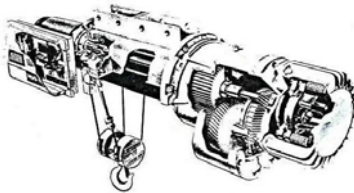

SIZE	UNIT	LOAD LIMIT	STOCK NO.
5 TON	EA	5 TON	304770
6 TON	EA	6 TON	304780

⚠ WARNING

To prevent the possibility of serious bodily injury:
 • **DO NOT EXCEED** the working load limits

TROLLEYS – BEAM CLAMPS

MANUAL TROLLEY



SIZE	WEIGHT	UNIT	WORKING LOAD LIMIT	STOCK NO.
1/2 TON	10.00 LBS	EA	1/2 TON	308410
1 TON	12.00 LBS	EA	1 TON	308430
2 TON	25.00 LBS	EA	2 TON	308450
3 TON	33.00 LBS	EA	3 TON	308460
5 TON	80.50 LBS	EA	5 TON	308470



GEARED TROLLEY

SIZE	WEIGHT	UNIT	WORKING LOAD LIMIT	STOCK NO.
3 TON	90.00 LBS	EA	3 TON	308460X
5 TON	121.00 LBS	EA	5 TON	308470X

BEAM CLAMP



SIZE	WEIGHT	UNIT	WORKING LOAD LIMIT	STOCK NO.
1 TON	11.00 LBS	EA	1 TON	308566
2 TON	12.00 LBS	EA	2 TON	308567
3 TON	26.00 LBS	EA	3 TON	308568
5 TON	34.00 LBS	EA	5 TON	308570
10 TON	75.00 LBS	EA	10 TON	308574

⚠ WARNING
To prevent the possibility of serious bodily injury: • DO NOT EXCEED the working load limits

WIRE ROPE CLIPS

MALLABLE WIRE ROPE CLIPS* (ELECTRO GALV.)



SIZE	WEIGHT	UNIT	BOX QTY	MINIMUM NO. OF CLIPS REQUIRED	TORQUE IN FT LBS	STOCK NO.
1/16"	0.03 LBS	EA	100	3	2	186002
1/8"	0.04 LBS	EA	100	3	3	186004
3/16"	0.63 LBS	EA	100	3	5	186006
1/4"	0.13 LBS	EA	100	3	15	186008
5/16"	0.15 LBS	EA	100	3	15	186010
3/8"	0.21 LBS	EA	100	3	30	186012
7/16"	0.24 LBS	EA	100	4	40	186014
1/2"	0.37 LBS	EA	100	4	45	186016
9/16"	0.59 LBS	EA	100	4	50	186018
5/8"	0.50 LBS	EA	50	4	75	186020
3/4"	0.75 LBS	EA	50	5	75	186024
7/8"	1.25 LBS	EA	50	5	130	186028
1"	1.50 LBS	EA	40	6	130	186032
1 1/8"	2.40 LBS	EA	40	7	200	186036
1 1/4"	2.60 LBS	EA	10	8		186040
1 3/8"	4.50 LBS	EA	10	8		186044
1 1/2"	5.00 LBS	EA	10	9		186048

***WARNING: NOT TO BE USED FOR OVERHEAD LIFTING!**

WARNING

To prevent the possibility of serious bodily injury:
 • DO NOT EXCEED the working load limits

WIRE ROPE CLIPS

DROP FORGED WIRE ROPE CLIPS (H.D. GALV.)



SIZE	WEIGHT	UNIT	BOX QTY	MINIMUM NO. OF CLIPS REQUIRED	TORQUE IN FT LBS.	STOCK NO.
1/8"	0.06 LBS	EA	100	2	4.5	183004
3/16"	0.10 LBS	EA	100	2	7.5	183006
1/4"	0.22 LBS	EA	100	2	15	183008
5/16"	0.33 LBS	EA	100	2	30	183010
3/8"	0.49 LBS	EA	100	2	45	183012
7/16"	0.70 LBS	EA	100	2	65	183014
1/2"	0.74 LBS	EA	100	3	65	183016
9/16"	1.00 LBS	EA	100	3	95	183018
5/8"	1.04 LBS	EA	50	3	95	183020
3/4"	1.51 LBS	EA	50	4	130	183024
7/8"	2.21 LBS	EA	25	4	225	183028
1"	2.61 LBS	EA	25	5	225	183032
1 1/8"	4.36 LBS	EA	25	6	225	183036
1 1/4"	4.60 LBS	EA	10	7	360	183040
1 3/8"	5.20 LBS	EA	10	7	360	183044
1 1/2"	5.90 LBS	EA	5	8	360	183048
1 3/4"	9.00 LBS	EA	5	8	430	183056
2"	13.00 LBS	EA	3	8	590	183064
2 1/4"	16.00 LBS	EA	3	8	750	183072
2 1/2"	19.00 LBS	EA	3	8	750	183080
2 3/4"	23.00 LBS	EA	3	10	750	183088

NOTE: SIZES 1/8" – 3/16" U-BOLTS & NUTS ARE ELECTRO GALVANIZED

CROSBY WIRE ROPE CLIPS (H.D.G.)

G-450



SIZE	WEIGHT	UNIT	BOX QTY	MINIMUM NO. OF CLIPS REQUIRED*	AMOUNT OF ROPE TO TURN BACK	TORQUE IN FT LBS.	STOCK NO.
1/8"	0.06 LBS	EA	100	2	3 1/4"	4.5	181504
3/16"	0.10 LBS	EA	100	2	3 3/4"	7.5	181506
1/4"	0.19 LBS	EA	100	2	4 3/4"	15	181508
5/16"	0.28 LBS	EA	100	2	5 1/4"	30	181510
3/8"	0.48 LBS	EA	100	2	6 1/2"	45	181512
7/16"	0.78 LBS	EA	50	2	7"	65	181514
1/2"	0.80 LBS	EA	50	3	11 1/2"	65	181516
9/16"	1.09 LBS	EA	50	3	12"	95	181518
5/8"	1.10 LBS	EA	50	3	12"	95	181520
3/4"	1.42 LBS	EA	25	4	18"	130	181524
7/8"	2.13 LBS	EA	25	4	19"	225	181528
1"	2.52 LBS	EA	10	5	26"	225	181532
1 1/8"	2.84 LBS	EA	10	6	34"	225	181536
1 1/4"	4.38 LBS	EA	10	7	44"	360	181540
1 3/8"	4.42 LBS	EA	10	7	44"	360	181544
1 1/2"	5.44 LBS	EA	10	8	54"	360	181548
1 5/8"	7.04 LBS	EA	BULK	8	58"	430	181552
1 3/4"	9.34 LBS	EA	BULK	8	61"	590	181556
2"	13.00 LBS	EA	BULK	8	71"	750	181564
2 1/4"	16.00 LBS	EA	BULK	8	73"	750	181572
2 1/2"	19.00 LBS	EA	BULK	9	84"	750	181580
3"	31.00 LBS	EA	BULK	10	106"	1200	181596
3 1/2"	40.00 LBS	EA	BULK	12	149"	1200	181599

***IF A PULLEY (SHEAVE) IS USED FOR TURNING BACK THE WIRE ROPE, ADD ONE (1) ADDITIONAL CLIP!**

⚠ WARNING

To prevent the possibility of serious bodily injury:
*** DO NOT EXCEED the working load limits**

WIRE ROPE CLIPS



WEDGE SOCKET CLIPS (H.D.G.)

SIZE	WEIGHT	UNIT	MINIMUM TAIL LENGTH	TORQUE (FT-LBS)*	STOCK NO.
7/16"	1.30 LBS	EA	6"	65	182514
1/2"	1.40 LBS	EA	6"	65	182516
9/16"	1.70 LBS	EA	6"	95	185218
5/8"	1.70 LBS	EA	6"	95	182520
3/4"	2.50 LBS	EA	6"	130	182524
7/8"	3.60 LBS	EA	6"	225	182528
1"	3.90LBS	EA	6"	225	182532

* THE TIGHTENING TORQUE VALUES SHOWN ARE BASED UPON THE THREADS BEING CLEAN, DRY AND FREE OF LUBRICATION.

FIST GRIP CLIP (H.D. GALVANIZED)

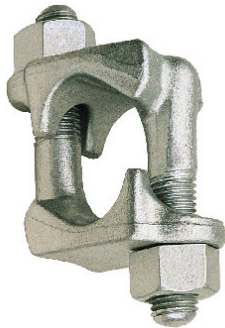

SIZE	WEIGHT	UNIT	BOX QTY	STOCK NO.
3/16" - 1/4"	0.23 LBS	EA	100	184506
5/16"	0.28 LBS	EA	100	184510
3/8"	0.40 LBS	EA	100	184512
7/16" - 1/2"	0.62 LBS	EA	50	184514
1/2"	0.62 LBS	EA	50	184516
9/16" - 5/8"	1.03 LBS	EA	25	184518
3/4"	1.75 LBS	EA	25	184524
7/8"	2.25 LBS	EA	25	184528
1"	3.00 LBS	EA	10	184532
1 1/8"	4.00 LBS	EA	10	184536
1 1/4"	4.00 LBS	EA	10	184540

⚠ WARNING

To prevent the possibility of serious bodily injury:
 • **DO NOT EXCEED** the working load limits

SHACKLES

ANCHOR STYLE

Nominal Shackles Size (in.) A	Working Load Limits * (tons)	Pin Dia. B	Dimensions (in.)			
			C	D	E	F
3/16	+ 1/3	1/4	7/8	3/8	19/32	9/16
1/4	1/2	5/16	1-1/8	15/32	25/32	11/16
5/16	3/4	3/8	1-1/4	17/32	27/32	3/4
3/8	1	7/16	1-7/16	21/32	31/32	15/16
7/16	1-1/2	1/2	1-3/4	23/32	1-5/32	1-1/8
1/2	2	5/8	1-15/16	13/16	1-1/4	1-1/4
5/8	3-1/4	3/4	2-7/16	1-1/6	1-9/16	1-7/16
3/4	4-3/4	7/8	2-13/16	1-1/4	1-13/16	1-3/4
7/8	6-1/2	1	3-1/8	1-7/16	2-1/16	2
1	8-1/2	1-1/8	3-3/4	1-11/16	2-1/2	2-3/8
1-1/8	9-1/2	1-1/4	4-1/4	1-13/16	2-15/16	2-5/8
1-1/4	12	1-3/8	4-1/2	2	3-1/4	3
1-3/8	13-1/2	1-1/2	5-1/4	2-1/4	3-1/2	3-1/4
1-1/2	17	1-5/8	5-3/4	2-3/8	3-7/8	3-1/2
1-5/8	20	1-3/4	6-1/4	2-5/8	4-1/4	3-5/8
1-3/4	25	2	7	2-7/8	4-3/4	4
2	35	2-1/4	7-3/4	3-1/4	5-3/4	4-7/8
2-1/4	40	2-1/2	9-1/4	3-3/4	6	5
2-1/2	55	2-3/4	10-9/16	4-1/8	7-1/4	5-1/2
2-3/4	60	3	11-1/2	4-1/2	7-1/2	6
3	75	3-1/4	13-1/8	5	8	6-1/2
3-1/2	100	3-3/4	15	5-3/4	9-1/2	7-3/8

* Furnished in screw pin only.
 * NOTE: Maximum Proof Load is 2.2 times the Working Load Limit. Minimum Ultimate Strength is 6 times the WLL.

CHAIN STYLE

Nominal Shackles Size (in.) A	Working Load Limits * (tons)	Pin Dia. B	Dimensions (in.)		
			C	D	F
1/4	1/2	5/16	7/8	15/32	11/16
5/16	3/4	3/8	1	17/32	13/16
3/8	1	7/16	1-1/4	21/32	15/16
7/16	1-1/2	1/2	1-1/2	23/32	1-1/8
1/2	2	5/8	1-11/16	13/16	1-1/4
5/8	3-1/4	3/4	2	1-1/16	1-7/16
3/4	4-3/4	7/8	2-5/16	1-1/4	1-3/4
7/8	6-1/2	1	2-7/8	1-7/16	2
1	8-1/2	1-1/8	3-1/4	1-11/16	2-3/8
1-1/8	9-1/2	1-1/4	3-1/2	1-13/16	2-3/4
1-1/4	12	1-3/8	3-7/8	2	3
1-3/8	13-1/2	1-1/2	4-1/2	2-1/4	3-1/8
1-1/2	17	1-5/8	5	2-3/8	3-1/2
1-5/8	20	1-3/4	5-1/4	2-5/8	3-5/8
1-3/4	25	2	5-7/8	2-7/8	4
2	35	2-1/4	6-3/4	3-1/4	4-7/8
2-1/4	40	2-1/2	7	3-3/4	5
2-1/2	55	2-3/4	8-1/16	4-1/8	5-1/2
2-3/4	60	3	8-9/16	4-1/2	6
3	75	3-1/4	9-1/16	5	6-1/2
3-1/2	100	3-3/4	10-1/2	5-3/4	7-3/8

* NOTE: Maximum Proof Load is 2.2 times the Working Load Limit. Minimum Ultimate Strength is 6 times WLL.

SHACKLES

ANCHOR SCREW PIN (INTERNATIONAL)



SIZE	WEIGHT	UNIT	WORKING LOAD LIMIT	STOCK NO.
3/16"	0.06 LBS	EA	1/3 TON	552006
1/4"	0.11 LBS	EA	1/2 TON	552008
5/16"	0.17 LBS	EA	3/4 TON	552010
3/8"	0.28 LBS	EA	1 TON	552012
7/16"	0.38 LBS	EA	1 1/2 TON	552014
1/2"	0.73 LBS	EA	2 TON	552016
5/8"	1.38 LBS	EA	3 1/4 TON	552020
3/4"	2.35 LBS	EA	4 3/4 TON	552024
7/8"	3.62 LBS	EA	6 1/2 TON	552028
1"	5.04 LBS	EA	8 1/2 TON	552032
1 1/8"	7.42 LBS	EA	9 1/2 TON	552036
1 1/4"	9.50 LBS	EA	12 TON	552040
1 3/8"	13.25 LBS	EA	13 1/2 TON	552044
1 1/2"	17.20 LBS	EA	17 TON	552048
1 3/4"	30.38 LBS	EA	25 TON	552056
2"	45.00 LBS	EA	35 TON	552064
2 1/2"	87.55 LBS	EA	55 TON	552080

ANCHOR SCREW PIN (DOMESTIC)



SIZE	WEIGHT	UNIT	WORKING LOAD LIMIT	STOCK NO.
3/16"	0.06 LBS	EA	1/3 TON	552006M
1/4"	0.11 LBS	EA	1/2 TON	552008M
5/16"	0.17 LBS	EA	3/4 TON	552010M
3/8"	0.28 LBS	EA	1 TON	552012M
7/16"	0.38 LBS	EA	1 1/2 TON	552014M
1/2"	0.73 LBS	EA	2 TON	552016M
5/8"	1.38 LBS	EA	3 1/4 TON	552020M
3/4"	2.35 LBS	EA	4 3/4 TON	552024M
7/8"	3.62 LBS	EA	6 1/2 TON	552028M
1"	5.04 LBS	EA	8 1/2 TON	552032M
1 1/8"	7.42 LBS	EA	9 1/2 TON	552036M
1 1/4"	9.50 LBS	EA	12 TON	552040M
1 3/8"	13.25 LBS	EA	13 1/2 TON	552044M
1 1/2"	17.20 LBS	EA	17 TON	552048M
1 3/4"	30.38 LBS	EA	25 TON	552056M
2"	45.00 LBS	EA	35 TON	552064M

WARNING

To prevent the possibility of serious bodily injury:
 • DO NOT EXCEED the working load limits

SHACKLES

ANCHOR BOLT TYPE (INTERNATIONAL)



SIZE	WEIGHT	UNIT	WORKING LOAD LIMIT	STOCK NO.
3/8"	0.33 LBS	EA	1 TON	551012
1/2"	0.82 LBS	EA	2 TON	551016
5/8"	1.68 LBS	EA	3 1/4 TON	551020
3/4"	2.72 LBS	EA	4 3/4 TON	551024
7/8"	3.95 LBS	EA	6 1/2 TON	551028
1"	5.56 LBS	EA	8 1/2 TON	551032
1 1/8"	8.27 LBS	EA	9 1/2 TON	551036
1 1/4"	11.71 LBS	EA	12 TON	551040
1 3/8"	15.83 LBS	EA	13 1/2 TON	551044
1 1/2"	20.80 LBS	EA	17 TON	551048
1 3/4"	34.72 LBS	EA	25 TON	551056
2"	52.25 LBS	EA	35 TON	551064
2 1/2"	98.25 LBS	EA	55 TON	551080
3"	154.00 LBS	EA	85 TON	551096

ANCHOR BOLT TYPE (DOMESTIC)



SIZE	WEIGHT	UNIT	WORKING LOAD LIMIT	STOCK NO.
3/16"	0.06 LBS	EA	1/3 TON	551006M
1/4"	0.11 LBS	EA	1/2 TON	551008M
5/16"	0.22 LBS	EA	3/4 TON	551010M
3/8"	0.33 LBS	EA	1 TON	551012M
7/16"	0.49 LBS	EA	1 1/2 TON	551014M
1/2"	0.82 LBS	EA	2 TON	551016M
5/8"	1.68 LBS	EA	3 1/4 TON	551020M
3/4"	2.72 LBS	EA	4 3/4 TON	551024M
7/8"	3.95 LBS	EA	6 1/2 TON	551028M
1"	5.56 LBS	EA	8 1/2 TON	551032M
1 1/8"	8.27 LBS	EA	9 1/2 TON	551036M
1 1/4"	11.71 LBS	EA	12 TON	551040M
1 3/8"	15.83 LBS	EA	13 1/2 TON	551044M
1 1/2"	20.80 LBS	EA	17 TON	551048M
1 3/4"	34.72 LBS	EA	25 TON	551056M
2"	52.25 LBS	EA	35 TON	551064M
2 1/2"	98.25 LBS	EA	55 TON	551080M
3"	154.00 LBS	EA	85 TON	551096M

⚠ WARNING
To prevent the possibility of serious bodily injury: * DO NOT EXCEED the working load limits

SHACKLES

SCREW PIN CHAIN (INTERNATIONAL)



SIZE	WEIGHT	UNIT	WORKING LOAD LIMIT	STOCK NO.
1/4"	0.11 LBS	EA	1/2 TON	554008
5/16"	0.17 LBS	EA	3/4 TON	554010
3/8"	0.28 LBS	EA	1 TON	554012
7/16"	0.40 LBS	EA	1 1/2 TON	554014
1/2"	0.59 LBS	EA	2 TON	554016
5/8"	1.26 LBS	EA	3 1/4 TON	554020
3/4"	2.25 LBS	EA	4 3/4 TON	554024
7/8"	3.25 LBS	EA	6 1/2 TON	554028
1"	4.75 LBS	EA	8 1/2 TON	554032
1 1/8"	6.75 LBS	EA	9 1/2 TON	554036
1 1/4"	9.06 LBS	EA	12 TON	554040
1 3/8"	11.63 LBS	EA	13 1/2 TON	554044
1 1/2"	15.95 LBS	EA	17 TON	554048
1 3/4"	26.75 LBS	EA	25 TON	554056
2"	42.31 LBS	EA	35 TON	554064
2 1/2"	71.75 LBS	EA	55 TON	554080

SCREW PIN CHAIN (DOMESTIC)



SIZE	WEIGHT	UNIT	WORKING LOAD LIMIT	STOCK NO.
1/4"	0.11 LBS	EA	1/2 TON	554008M
5/16"	0.17 LBS	EA	3/4 TON	554010M
3/8"	0.28 LBS	EA	1 TON	554012M
7/16"	0.40 LBS	EA	1 1/2 TON	554014M
1/2"	0.59 LBS	EA	2 TON	554016M
5/8"	1.26 LBS	EA	3 1/4 TON	554020M
3/4"	2.25 LBS	EA	4 3/4 TON	554024M
7/8"	3.25 LBS	EA	6 1/2 TON	554028M
1"	4.75 LBS	EA	8 1/2 TON	554032M
1 1/8"	6.75 LBS	EA	9 1/2 TON	554036M
1 1/4"	9.06 LBS	EA	12 TON	554040M
1 3/8"	11.63 LBS	EA	13 1/2 TON	554044M
1 1/2"	15.95 LBS	EA	17 TON	554048M
1 3/4"	26.75 LBS	EA	25 TON	554056M
2"	42.31 LBS	EA	35 TON	554064M
2 1/2"	71.75 LBS	EA	55 TON	554080M

⚠ WARNING

To prevent the possibility of serious bodily injury:
 • DO NOT EXCEED the working load limits

SHACKLES

BOLT TYPE CHAIN (INTERNATIONAL)



SIZE	WEIGHT	UNIT	WORKING LOAD LIMIT	STOCK NO.
1/4"	0.13 LBS	EA	1/2 TON	553008
5/16"	0.23 LBS	EA	3/4 TON	553010
3/8"	0.33 LBS	EA	1 TON	553012
7/16"	0.49 LBS	EA	1 1/2 TON	553014
1/2"	0.75 LBS	EA	2 TON	553016
5/8"	1.47 LBS	EA	3 1/4 TON	553020
3/4"	2.52 LBS	EA	4 3/4 TON	553024
7/8"	3.85 LBS	EA	6 1/2 TON	553028
1"	5.55 LBS	EA	8 1/2 TON	553032
1 1/8"	7.60 LBS	EA	9 1/2 TON	553036
1 1/4"	10.81 LBS	EA	12 TON	553040
1 3/8"	13.75 LBS	EA	13 1/2 TON	553044

BOLT TYPE CHAIN (DOMESTIC)



SIZE	WEIGHT	UNIT	WORKING LOAD LIMIT	STOCK NO.
1/4"	0.13 LBS	EA	1/2 TON	553008M
5/16"	0.23 LBS	EA	3/4 TON	553010M
3/8"	0.33 LBS	EA	1 TON	553012M
7/16"	0.49 LBS	EA	1 1/2 TON	553014M
1/2"	0.75 LBS	EA	2 TON	553016M
5/8"	1.47 LBS	EA	3 1/4 TON	553020M
3/4"	2.52 LBS	EA	4 3/4 TON	553024M
7/8"	3.85 LBS	EA	6 1/2 TON	553028M
1"	5.55 LBS	EA	8 1/2 TON	553032M
1 1/8"	7.60 LBS	EA	9 1/2 TON	553036M
1 1/4"	10.81 LBS	EA	12 TON	553040M
1 3/8"	13.75 LBS	EA	13 1/2 TON	553044M

WARNING

To prevent the possibility of serious bodily injury:
 • DO NOT EXCEED the working load limits

SHACKLES

ROUND PIN ANCHOR (DOMESTIC)



SIZE	WEIGHT	UNIT	WORKING LOAD LIMIT	STOCK NO.
1/4"	0.13 LBS	EA	1/2 TON	551508M
5/16"	0.18 LBS	EA	3/4 TON	551510M
3/8"	0.29 LBS	EA	1 TON	551512M
7/16"	0.38 LBS	EA	1.5 TON	551514C
1/2"	0.59 LBS	EA	2 TON	551516M
5/8"	1.50 LBS	EA	3 1/4 TON	551520M
3/4"	2.32 LBS	EA	4 3/4 TON	551524M

ALLOY SCREW PIN ANCHOR (DOMESTIC)



SIZE	WEIGHT	UNIT	WORKING LOAD LIMIT	STOCK NO.
3/8"	0.32 LBS	EA	2 TON	552112M
7/16"	0.38 LBS	EA	2.6 TON	552114M
1/2"	0.63 LBS	EA	3.3 TON	552116M
5/8"	1.38 LBS	EA	5 TON	552120M
3/4"	2.25 LBS	EA	7 TON	552124M
7/8"	3.62 LBS	EA	9.5 TON	552128M
1"	5.32 LBS	EA	12.5 TON	552132M
1 1/8"	7.25 LBS	EA	15 TON	552136M
1 1/2"	17.50 LBS	EA	25 TON	552148M

WEB SLING SHACKLE (BOLT TYPE)



SIZE	WEIGHT	UNIT	WORKING LOAD LIMIT	STOCK NO.
4"	3.20 LBS	EA	14,500 LBS	557514
5"	4.95 LBS	EA	19,000 LBS	557515
6"	10.00 LBS	EA	22,500 LBS	557516

⚠ WARNING

To prevent the possibility of serious bodily injury:
 • DO NOT EXCEED the working load limits

SHACKLES

STRAIGHT CLEVIS



SIZE	WEIGHT	UNIT	WORKING LOAD LIMIT	STOCK NO.
5/8"	1.50 LBS	EA	NOT RATED	556920
3/4"	3.00 LBS	EA	NOT RATED	556924
7/8"	3.50 LBS	EA	NOT RATED	556928

TWISTED CLEVIS



SIZE	WEIGHT	UNIT	WORKING LOAD LIMIT	STOCK NO.
5/8"	1.50 LBS	EA	NOT RATED	557020
3/4"	3.00 LBS	EA	NOT RATED	577024
7/8"	3.50 LBS	EA	NOT RATED	557028

COMMERCIAL ANCHOR SCREW PIN (INTERNATIONAL)

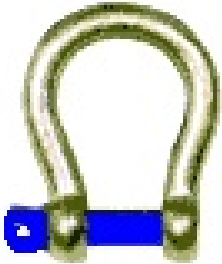

SIZE	WEIGHT	UNIT	LOAD LIMIT	STOCK NO.
1/4"	.066 LBS	EA	NOT RATED	551708
5/16"	.154 LBS	EA	NOT RATED	551710
3/8"	.286 LBS	EA	NOT RATED	551712
7/16"	.396 LBS	EA	NOT RATED	551714
1/2"	.572 LBS	EA	NOT RATED	551716
5/8"	1.10 LBS	EA	NOT RATED	551720
3/4"	1.76 LBS	EA	NOT RATED	551724
7/8"	2.86 LBS	EA	NOT RATED	551728
1"	4.40 LBS	EA	NOT RATED	551732
1 1/4"	9.46 LBS	EA	NOT RATED	551740
1 1/2"	15.40 LBS	EA	NOT RATED	551748

NOTE: PLEASE STATE BLUE COLORED PIN WHEN ORDERING.

NOTE: NONE OF THE ITEMS ON THIS PAGE ARE RATED FOR OVERHEAD LIFTING!

WARNING

To prevent the possibility of serious bodily injury:
 * DO NOT EXCEED the working load limits

HOOKS

HOOKS

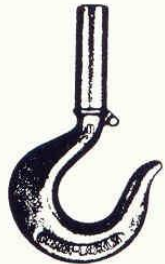

SHANK



SWIVEL



CLEVIS GRAB

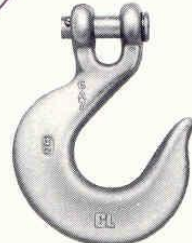

CLEVIS SLIP

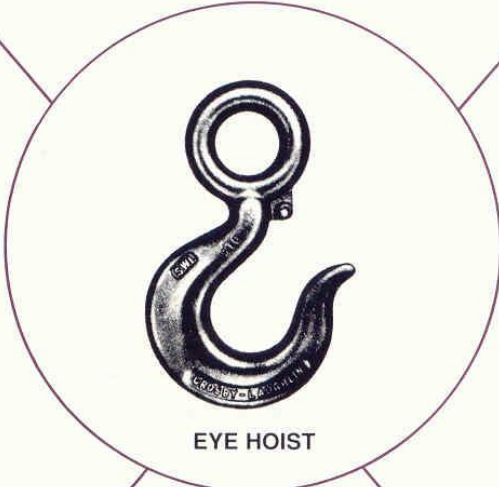

EYE HOIST



EYE GRAB

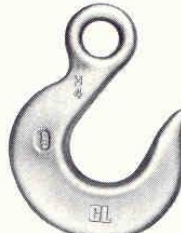

EYE SLIP



SLIDING CHOKER



SELF LOCKING



SORTING

SAFETY LATCHES AVAILABLE

HOOKS

CARBON EYE HOIST HOOK (INTERNATIONAL) WITH STAINLESS STEEL LATCH



SIZE	WEIGHT	UNIT	WORKING LOAD LIMIT	STOCK NO.
3/4 TON	0.61 LBS	EA	3/4 TON	261602
1 TON	0.89 LBS	EA	1 TON	261603
1 1/2 TON	1.44 LBS	EA	1 1/2 TON	261604
2 TON	2.07 LBS	EA	2 TON	261605
3 TON	4.30 LBS	EA	3 TON	261607
5 TON	8.30 LBS	EA	5 TON	261610
7 1/2 TON	15.00 LBS	EA	7 1/2 TON	261613

ELECTRO-GALVANIZED EYE HOIST HOOK (INTERNATIONAL) WITH STAINLESS STEEL LATCH



SIZE	WEIGHT	UNIT	WORKING LOAD LIMIT	STOCK NO.
3/4 TON	0.61 LBS	EA	3/4 TON	261652
1 TON	0.89 LBS	EA	1 TON	261653
1 1/2 TON	1.44 LBS	EA	1 1/2 TON	261654
2 TON	2.07 LBS	EA	2 TON	261655

CARBON EYE HOIST NO LATCH (DOMESTIC)



SIZE	WEIGHT	UNIT	WORKING LOAD LIMIT	STOCK NO.
3/4 TON	0.62 LBS	EA	3/4 TON	261202C
1 TON	0.90 LBS	EA	1 TON	261203C
1 1/2 TON	1.45 LBS	EA	1 1/2 TON	261204C
2 TON	2.00 LBS	EA	2 TON	261205C
3 TON	4.25 LBS	EA	3 TON	261207C
5 TON	8.45 LBS	EA	5 TON	261210C
7 1/2 TON	15.12 LBS	EA	7 1/2 TON	261213C
10 TON	22.75 LBS	EA	10 TON	261214C
15 TON	39.50 LBS	EA	15 TON	261217C
20 TON	60.00 LBS	EA	20 TON	261218C
25 TON	105.00 LBS	EA	25 TON	261220C
30 TON	148.00 LBS	EA	30 TON	261221C

WARNING

To prevent the possibility of serious bodily injury:
 • **DO NOT EXCEED** the working load limits

HOOKS

ALLOY EYE HOIST HOOK WITH LATCH (INTERNATIONAL)



SIZE	WEIGHT	UNIT	WORKING LOAD LIMIT	STOCK NO.
1 TON	0.62 LBS	EA	1 TON	251603
1 1/2 TON	0.90 LBS	EA	1 1/2 TON	251604
2 TON	2.00 LBS	EA	2 TON	251605
3 TON	4.25 LBS	EA	3 TON	251607
5 TON	8.45 LBS	EA	5 TON	251609
7 TON	15.12 LBS	EA	7 TON	251612
11 TON	22.75 LBS	EA	11 TON	251615
15 TON	22.75 LBS	EA	15 TON	251617
22 TON	39.51 LBS	EA	22 TON	251619

ALLOY EYE HOIST NO LATCH (DOMESTIC)



SIZE	WEIGHT	UNIT	WORKING LOAD LIMIT	STOCK NO.
1 TON	0.62 LBS	EA	1 TON	251203M
1 1/2 TON	0.90 LBS	EA	1 1/2 TON	251204M
2 TON	1.45 LBS	EA	2 TON	251205M
3 TON	2.00 LBS	EA	3 TON	251207M
5 TON	4.30 LBS	EA	5 TON	250209M
7 TON	8.30 LBS	EA	7 TON	251212M
11 TON	15.12 LBS	EA	11 TON	251215M
15 TON	21.60 LBS	EA	15 TON	251217M
22 TON	39.50 LBS	EA	22 TON	251219M

ALLOY EYE HOIST HOOK NO LATCH (CROSBY)



SIZE	WEIGHT	UNIT	WORKING LOAD LIMIT	STOCK NO.
1 TON	0.62 LBS	EA	1 TON	251203C
1 1/2 TON	0.90 LBS	EA	1 1/2 TON	251204C
2 TON	1.45 LBS	EA	2 TON	251205C
3 TON	2.00 LBS	EA	3 TON	251207C
5 TON	4.30 LBS	EA	5 TON	251209C
7 TON	8.30 LBS	EA	7 TON	251212C
11 TON	15.12 LBS	EA	11 TON	251215C
15 TON	21.60 LBS	EA	15 TON	251217C
22 TON	39.50 LBS	EA	22 TON	251219C

WARNING

To prevent the possibility of serious bodily injury:
 • **DO NOT EXCEED** the working load limits

HOOKS

ALLOY SWIVEL HOOK (INTERNATIONAL) WITH STAINLESS STEEL LATCH



SIZE	WEIGHT	UNIT	WORKING LOAD LIMIT	STOCK NO.
1 TON	0.80 LBS	EA	1 TON	252403
1 1/2 TON	1.25 LBS	EA	1 1/2 TON	252404
2 TON	2.30 LBS	EA	2 TON	252405
3 TON	3.28 LBS	EA	3 TON	252407
4 1/2 TON	4.50 LBS	EA	4 1/2 TON	252409
5 TON	4.97 LBS	EA	5 TON	252410
7 TON	10.29 LBS	EA	7 TON	252412
11 TON	16.20 LBS	EA	11 TON	252415
15 TON	23.25 LBS	EA	15 TON	252417
22 TON	49.75 LBS	EA	22 TON	252419

ALLOY SWIVEL HOOK (DOMESTIC)



SIZE	WEIGHT	UNIT	WORKING LOAD LIMIT	STOCK NO.
1 TON	1.27 LBS	EA	1 TON	252403M
1 1/2 TON	1.25 LBS	EA	1 1/2 TON	252404M
2 TON	2.75 LBS	EA	2 TON	252405M
3 TON	3.28 LBS	EA	3 TON	252407M
5 TON	7.20 LBS	EA	5 TON	252409M
7 TON	13.60 LBS	EA	7 TON	252412M
11 TON	16.20 LBS	EA	11 TON	252415C
15 TON	23.25 LBS	EA	15 TON	252417C
22 TON	49.75 LBS	EA	22 TON	252419C



REPLACEMENT HOOK-CHAIN HOIST

SIZE	WEIGHT	UNIT	WORKING LOAD LIMIT	STOCK NO.
1/2 TON	1.25 LBS	EA	1/2 TON	256801
1 TON	2.60 LBS	EA	1 TON	256803

WARNING

To prevent the possibility of serious bodily injury:
 • DO NOT EXCEED the working load limits

HOOKS

TRU-LOC ALLOY SWIVEL SAFETY HOOK



SIZE	TYPE	WEIGHT	UNIT	WORKING LOAD LIMIT	STOCK NO.
7/32"	5-6.	1.50 LBS	EA	2,500 LBS	252501
9/32"	7-8.	3.10 LBS	EA	4,500 LBS	252502
3/8"	10	5.26 LBS	EA	7,100 LBS	252512
1/2"	13	8.64 LBS	EA	12,000 LBS	252516
5/8"	16	17.00 LBS	EA	18,100 LBS	252520

TRU-LOC SELF LOCKING EYE HOOK



SIZE	TYPE	WEIGHT	UNIT	WORKING LOAD LIMIT	STOCK NO.
7/32"	SL-6	1.00 LBS	EA	2,100 LBS	254006
9/32"	SL-7	2.20 LBS	EA	4,500 LBS	254007
3/8"	SL-10	3.24 LBS	EA	7,100 LBS	254010
1/2"	SL-13	5.96 LBS	EA	12,000 LBS	254013

TRU-LOC ALLOY CLEVIS SLING HOOK



SIZE	WEIGHT	UNIT	WORKING LOAD LIMIT	STOCK NO.
1/4"-5/16"	1.81 LBS	EA	3,500 LBS	253708
3/8"	3.42 LBS	EA	7,100 LBS	253712
1/2"	5.96 LBS	EA	12,000 LBS	253716
5/8"	12.75 LBS	EA	18,100 LBS	253720

WARNING

To prevent the possibility of serious bodily injury:
 • **DO NOT EXCEED** the working load limits

HOOKS

CARBON SHANK HOOK



SIZE	WEIGHT	UNIT	WORKING LOAD LIMIT	STOCK NO.
3/4 TON	0.65 LBS	EA	3/4 TON	267702
1 1/2 TON	1.20 LBS	EA	1 1/2 TON	267704
2 TON	1.85 LBS	EA	2 TON	267705
5 TON	7.25 LBS	EA	5 TON	267710
7 1/2 TON	13.49 LBS	EA	7 1/2 TON	267713
10 TON	18.00 LBS	EA	10 TON	267714
15 TON	35.00 LBS	EA	15 TON	267717
20 TON	85.50 LBS	EA	20 TON	267801
25 TON	134.00 LBS	EA	25 TON	267802
30 TON	182.00 LBS	EA	30 TON	267804

ALLOY SHANK HOOK



SIZE	WEIGHT	UNIT	WORKING LOAD LIMIT	STOCK NO.
1 TON	0.65 LBS	EA	1 TON	257703
1 1/2 TON	0.75 LBS	EA	1 1/2 TON	257704
2 TON	1.20 LBS	EA	2 TON	257705
3 TON	1.85 LBS	EA	3 TON	257707
5 TON	3.85 LBS	EA	5 TON	257709
7 TON	7.25 LBS	EA	7 TON	257712
11 TON	13.40 LBS	EA	11 TON	257715
15 TON	18.00 LBS	EA	15 TON	257717
22 TON	35.23 LBS	EA	22 TON	257719
30 TON 10"	72.00 LBS	EA	30 TON	257800
30 TON, 18"	85.50 LBS	EA	30 TON	257801
37 TON, 15"	134.00 LBS	EA	37 TON	257802
200 TON, 20"	1,020.00 LBS	EA	200 TON	257898

SAFETY SNAP HOOK



SIZE	DESCRIPTION	WEIGHT	UNIT	WORKING LOAD LIMIT	STOCK NO.
7/16"	SAFETY SNAP HOOK	0.26 LBS	EA	750 LBS	268100
7/16"	MAGNAFLUXED SAFETY HOOK	0.26 LBS	EA	750 LBS	268100.1
9/16"	SAFETY SNAP HOOK	0.51 LBS	EA	1,000 LBS	268101

⚠ WARNING

To prevent the possibility of serious bodily injury:
 • **DO NOT EXCEED** the working load limits

HOOKS

ROLLOX BULLARD® HOOK-CROSBY SELF-CLOSING, BL-C



SIZE	WEIGHT	UNIT	WORKING LOAD LIMIT	STOCK NO.
1C	0.80 LBS	EA	0.50 TONS	254441
3C	1.90 LBS	EA	1.40 TONS	254443
5C	2.30 LBS	EA	2.30 TONS	254445
8C	9.60 LBS	EA	5.50 TONS	254448

ROLLOX BULLARD® HOOK, CROSBY SELF-CLOSING, BL-D



SIZE	WEIGHT	UNIT	WORKING LOAD LIMIT	STOCK NO.
2D	1.10 LBS	EA	1.00 TONS	254462
7D	5.20 LBS	EA	4.20 TONS	254467

ROLLOX BULLARD® HOOK, CROSBY LINK CHAIN NEST, SELF-CLOSING, BL-O



SIZE	WEIGHT	UNIT	WORKING LOAD LIMIT	STOCK NO.
1/4"	2.50 LBS	EA	1.70 TONS	254540
5/16"-3/8"	4.50 LBS	EA	2.30 TONS	254545

ROLLOX BULLARD® HOOK, CROSBY ROLLER CHAIN NEST, SELF-CLOSING, BL-S



SIZE	WEIGHT	UNIT	WORKING LOAD LIMIT	STOCK NO.
4S	2.90 LBS	EA	0.75 TONS	254584
6S	6.20 LBS	EA	1.25 TONS	254586

WARNING

To prevent the possibility of serious bodily injury:
 • **DO NOT EXCEED** the working load limits

HOOKS

CLEVIS GRAB HOOK (INTERNATIONAL) HIGH TEST, SELF COLORED, QUENCHED & TEMPERED CARBON



SIZE	WEIGHT	UNIT	WORKING LOAD LIMIT	STOCK NO.
1/4"	0.36 LBS	EA	2,600 LBS	260308
5/16"	0.63 LBS	EA	3,900 LBS	260310
3/8"	1.00 LBS	EA	5,400 LBS	260312
7/16"	1.52 LBS	EA	7,200 LBS	260314
1/2"	2.22 LBS	EA	9,200 LBS	260316
5/8"	4.40 LBS	EA	13,000 LBS	260320
3/4"	6.50 LBS	EA	20,200 LBS	260324

CLEVIS GRAB HOOK (DOMESTIC) HIGH TEST, SELF COLORED, QUENCHED & TEMPERED CARBON



SIZE	WEIGHT	UNIT	WORKING LOAD LIMIT	STOCK NO.
1/4"	0.36 LBS	EA	2,600 LBS	260308M
5/16"	0.63 LBS	EA	3,900 LBS	260310M
3/8"	1.00 LBS	EA	5,400 LBS	260312M
7/16"	1.52 LBS	EA	7,200 LBS	260314M
1/2"	2.22 LBS	EA	9,200 LBS	260316M
5/8"	4.40 LBS	EA	13,000 LBS	260320M
3/4"	6.50 LBS	EA	20,200 LBS	260324M

CLEVIS GRAB HOOK (INTERNATIONAL) ELECTRO GLAVANIZED, CARBON, HIGH TEST



SIZE	WEIGHT	UNIT	WORKING LOAD LIMIT	STOCK NO.
1/4"	0.36 LBS	EA	2,600 LBS	265508
5/16"	0.62 LBS	EA	3,900 LBS	265510
3/8"	1.10 LBS	EA	5,400 LBS	265512
7/16"	1.60 LBS	EA	7,200 LBS	265514
1/2"	2.42 LBS	EA	9,200 LBS	265516

WARNING

To prevent the possibility of serious bodily injury:
 * DO NOT EXCEED the working load limits

HOOKS

CLEVIS GRAB HOOK (INTERNATIONAL) GRADE 80 ALLOY, QUENCHED & TEMPERED



SIZE	WEIGHT	UNIT	WORKING LOAD LIMIT	STOCK NO.
1/4"	0.36 LBS	EA	3,500 LBS	250308
5/16"	0.63 LBS	EA	4,500 LBS	250310
3/8"	1.00 LBS	EA	7,100 LBS	250312
7/16"	1.52 LBS	EA	6,900 LBS	250314
1/2"	2.20 LBS	EA	12,000 LBS	250316
5/8"	4.40 LBS	EA	15,800 LBS	250320
3/4"	6.50 LBS	EA	24,700 LBS	250324

CLEVIS GRAB HOOK (DOMESTIC) GRADE 80, ALLOY, HOT FORGED, HEAT TREATED & TEMPERED



SIZE	WEIGHT	UNIT	WORKING LOAD LIMIT	STOCK NO.
1/4"	0.36 LBS	EA	3,500 LBS	250308M
5/16"	0.63 LBS	EA	4,500 LBS	250310M
3/8"	1.00 LBS	EA	7,100 LBS	250312M
7/16"	1.52 LBS	EA	6,900 LBS	250314M
1/2"	2.20 LBS	EA	12,000 LBS	250316M
5/8"	4.40 LBS	EA	15,800 LBS	250320M

CLEVIS GRAB HOOK (INTERNATIONAL) GRADE 70, YELLOW, QUENCHED & TEMPERED



SIZE	WEIGHT	UNIT	WORKING LOAD LIMIT	STOCK NO.
1/4"	0.40 LBS	EA	3,150 LBS	265308
5/16"	0.75 LBS	EA	4,700 LBS	265310
3/8"	1.10 LBS	EA	6,600 LBS	265312
1/2"	2.22 LBS	EA	10,800 LBS	265316
5/8"	4.41 LBS	EA		265320

WARNING

To prevent the possibility of serious bodily injury:
 • **DO NOT EXCEED** the working load limits

HOOKS

EYE GRAB HOOK (INTERNATIONAL) FORGED STEEL, QUENCHED, CARBON -PROOF COIL



SIZE	WEIGHT	UNIT	WORKING LOAD LIMIT	STOCK NO.
5/16"	0.52 LBS	EA	1,900 LBS	265610
3/8"	0.83 LBS	EA	2,650 LBS	265612
7/16"	1.38 LBS	EA	3,700 LBS	265614
1/2"	1.95 LBS	EA	4,500 LBS	265616
5/8"	3.72 LBS	EA	6,900 LBS	265620
3/4"	3.73 LBS	EA	10,600 LBS	265624

EYE GRAB HOOK (INTERNATIONAL) FORGED STEEL, HIGH TEST, ELECTRO GALVANIZED



SIZE	WEIGHT	UNIT	WORKING LOAD LIMIT	STOCK NO.
1/4"	0.28 LBS	EA	2,600 LBS	265908
5/16"	0.45 LBS	EA	3,900 LBS	265910
3/8"	0.79 LBS	EA	5,400 LBS	265912
1/2"	1.75 LBS	EA	9,200 LBS	265916

EYE GRAB HOOK (DOMESTIC) FORGED STEEL, QUENCHED & TEMPERED, HIGH TEST



SIZE	WEIGHT	UNIT	WORKING LOAD LIMIT	STOCK NO.
1/4"	0.28 LBS	EA	2,600 LBS	261308M
5/16"	0.45 LBS	EA	3,900 LBS	261310M
3/8"	0.90 LBS	EA	5,400 LBS	261312M
1/2"	1.75 LBS	EA	9,200 LBS	261316M
5/8"	3.25 LBS	EA	13,000 LBS	261320M

⚠ WARNING
To prevent the possibility of serious bodily injury: • DO NOT EXCEED the working load limits

HOOKS

EYE GRAB HOOK (DOMESTIC) FORGED STEEL, HEAT TREATED & TEMPERED, ALLOY



SIZE	WEIGHT	UNIT	WORKING LOAD LIMIT	STOCK NO.
1/4"	0.28 LBS	EA	3,500 LBS	251308M
5/16"	0.45 LBS	EA	4,500 LBS	251310M
3/8"	0.90 LBS	EA	7,100 LBS	251312M
1/2"	1.75 LBS	EA	12,000 LBS	251316M
5/8"	3.25 LBS	EA	18,100 LBS	251320M

CLEVIS SLIP HOOK (INTERNATIONAL) HIGH TEST, SELF-COLORED, QUENCHED & TEMPERED CARBON



SIZE	WEIGHT	UNIT	WORKING LOAD LIMIT	STOCK NO.
1/4"	0.55 LBS	EA	1,950 LBS	260808
5/16"	0.78 LBS	EA	2,875 LBS	260810
3/8"	1.20 LBS	EA	4,000 LBS	260812
7/16"	2.06 LBS	EA	5,000 LBS	260814
1/2"	2.83 LBS	EA	6,500 LBS	260816
5/8"	4.75 LBS	EA	9,250 LBS	260820
3/4"	11.28 LBS	EA	9,750 LBS	260824

NOTE: NOT FOR LIFTING

CLEVIS SLIP HOOK (DOMESTIC) HIGH TEST, SELF-COLORED, QUENCHED & TEMPERED, CARBON



SIZE	WEIGHT	UNIT	WORKING LOAD LIMIT	STOCK NO.
1/4"	0.55 LBS	EA	1,950 LBS	260808M
5/16"	0.70 LBS	EA	2,875 LBS	260810M
3/8"	1.20 LBS	EA	4,000 LBS	260812M
7/16"	2.06 LBS	EA	5,000 LBS	260814M
1/2"	2.83 LBS	EA	6,500 LBS	260816M
5/8"	4.75 LBS	EA	9,250 LBS	260820M

⚠ WARNING

To prevent the possibility of serious bodily injury:
 • **DO NOT EXCEED** the working load limits

HOOKS

CLEVIS SLIP HOOK WITH SS LATCH (INTERNATIONAL) CARBON, FORGED STEEL, HIGH TEST, ZINC PLATED



SIZE	WEIGHT	UNIT	WORKING LOAD LIMIT	STOCK NO.
1/4"	0.35 LBS	EA	2,600 LBS	260908
5/16"	0.63 LBS	EA	3,900 LBS	260910
3/8"	1.02 LBS	EA	5,400 LBS	260912
1/2"	2.27 LBS	EA	9,200 LBS	260916

NOT FOR LIFTING

CLEVIS SLIP HOOK WITH SS LATCH GRADE 70, FORGED STEEL, YELLOW ZINC PLATED



SIZE	WEIGHT	UNIT	WORKING LOAD LIMIT	STOCK NO.
1/4"	0.55 LBS	EA	2,750 LBS	250908
5/16"	0.90 LBS	EA	4,300 LBS	250910
3/8"	1.37 LBS	EA	5,250 LBS	250912
1/2"	1.84 LBS	EA	9,000 LBS	250916

NOT FOR LIFTING

CLEVIS SLIP HOOK WITH LATCH (DOMESTIC) HIGH TEST, FORGED STEEL, GALVANIZED, CARBON



SIZE	WEIGHT	UNIT	WORKINGLOAD	
			LIMIT	STOCKNO
1/4"	0.35 LBS	EA	2,600 LBS	260908M
5/16"	0.63 LBS	EA	3,900 LBS	260910M
3/8"	1.02 LBS	EA	5,400 LBS	260912M
1/2"	2.27 LBS	EA	9,200 LBS	260916M

⚠ WARNING

To prevent the possibility of serious bodily injury:
• **DO NOT EXCEED** the working load limits

HOOKS

CLEVIS SLIP HOOK (INTERNATIONAL) ALLOY



SIZE	WEIGHT	UNIT	WORKING LOAD LIMIT	STOCK NO.
1/4"	0.55 LBS	EA	2,750 LBS	250808
5/16"	0.78 LBS	EA	3,600 LBS	250810
3/8"	1.20 LBS	EA	5,500 LBS	250812
7/16"	2.06 LBS	EA	6,900 LBS	250814
1/2"	2.83 LBS	EA	9,400 LBS	250816
5/8"	4.75 LBS	EA	14,200 LBS	250820
3/4"	11.28 LBS	EA	19,250 LBS	250824

NOTE: NOT FOR LIFTING!

CLEVIS SLIP HOOK (DOMESTIC) ALLOY, FORGED STEEL



SIZE	WEIGHT	UNIT	WORKING LOAD LIMIT	STOCK NO.
1/4"	0.55 LBS	EA	2,750 LBS	250808M
5/16"	0.78 LBS	EA	3,600 LBS	250810M
3/8"	1.20 LBS	EA	5,250 LBS	250812M
7/16"	2.06 LBS	EA	6,900 LBS	250814M
1/2"	2.75 LBS	EA	9,000 LBS	250916M
5/8"	4.75 LBS	EA	13,500 LBS	250820M
3/4"	11.28 LBS	EA	19,250 LBS	250824C

NOTE: NOT FOR LIFTING!

CLEVIS SLIP HOOK (INTERNATIONAL) HIGH TEST, ELECTRO GALVANIZED



SIZE	WEIGHT	UNIT	WORKING LOAD LIMIT	STOCK NO.
1/4"	0.35 LBS	EA	1,950 LBS	265708
5/16"	0.63 LBS	EA	2,875 LBS	265710
3/8"	1.02 LBS	EA	4,000 LBS	265712
1/2"	2.27 LBS	EA	6,500 LBS	265716
3/4"	10.75 LBS	EA	9,250 LBS	265724

EYE SLIP HOOK (INTERNATIONAL) FORGED STEEL, HIGH TEST, CARBON



SIZE	WEIGHT	UNIT	WORKING LOAD LIMIT	STOCK NO.
1/4"	0.40 LBS	EA	1,950 LBS	262208
5/16"	0.65 LBS	EA	2,875 LBS	262210
3/8"	1.10 LBS	EA	4,000 LBS	262212
7/16"	1.56 LBS	EA	5,000 LBS	262214
1/2"	2.09 LBS	EA	6,500 LBS	262216
5/8"	3.90 LBS	EA	9,250 LBS	262220
3/4"	6.93 LBS	EA	12,500 LBS	262224

WARNING

To prevent the possibility of serious bodily injury:
• **DO NOT EXCEED** the working load limits

HOOKS

EYE SLIP HOOK (DOMESTIC) FORGED STEEL, HIGH TEST, CARBON



SIZE	WEIGHT	UNIT	WORKING LOAD LIMIT	STOCK NO.
1/4"	0.40 LBS	EA	1,950 LBS	262208C
5/16"	0.65 LBS	EA	2,875 LBS	262210C
3/8"	1.10 LBS	EA	4,000 LBS	262212C
7/16"	1.56 LBS	EA	5,000 LBS	262214C
1/2"	2.09 LBS	EA	6,500 LBS	262216C
5/8"	3.90 LBS	EA	9,250 LBS	262220C
3/4"	6.93 LBS	EA	12,500 LBS	262224C

SORTING HOOK (DOMESTIC)



SIZE	WEIGHT	UNIT	WORKING LOAD LIMIT	STOCK NO.
2 TON	6.20 LBS	EA	SEE NOTE	258305

NOTE: WLL IS 2TON TIP OF HOOK, 7 TON BOTTOM OF HOOK

SLIDING CHOKER HOOK (DOMESTIC)



SIZE	DESCRIPTION	WEIGHT	UNIT	WORKING LOAD LIMIT	STOCK NO.
3/8"	SLIDING CHOKER	0.77 LBS	EA	2,500 LBS	257900
1/2"	SLIDING CHOKER	1.19 LBS	EA	3,300 LBS	257901
5/8"	SLIDING CHOKER, SM	2.70 LBS	EA	5,000 LBS	257902
5/8"	SLIDING CHOKER, LG	2.89 LBS	EA	5,000 LBS	257903
3/4"	SLIDING CHOKER, SM	2.95 LBS	EA	8,000 LBS	257904
3/4"	SLIDING CHOKER, LG	5.00 LBS	EA	8,000 LBS	257905
7/8"-1"	SLIDING CHOKER, LG	9.70 LBS	EA	15,000 LBS	257906

⚠ WARNING

To prevent the possibility of serious bodily injury:

• **DO NOT EXCEED** the working load limits

HOOKS

CLEVIS SLIP HOOK

FORGED STEEL, ALLOY, FOR OVERHEAD LIFTING



SIZE	WEIGHT	UNIT	WORKING LOAD LIMIT	STOCK NO.
1/4"	2.21 LBS	EA	3,500 LBS	250608
3/8"	2.43 LBS	EA	7,100 LBS	250612
1/2"	4.30 LBS	EA	12,000 LBS	250616
5/8"	7.49 LBS	EA	18,100 LBS	250620
3/4"	13.70 LBS	EA	28,300 LBS	250624
7/8"	15.65 LBS	EA	34,200 LBS	250628

CLEVIS SLIP HOOK WITH LATCH

FORGED STEEL, ALLOY, FOR OVERHEAD LIFTING



SIZE	WEIGHT	UNIT	WORKING LOAD LIMIT	STOCK NO.
1/4"	2.21 LBS	EA	3,500 LBS	250608L
3/8"	2.43 LBS	EA	7,100 LBS	250612L
1/2"	4.30 LBS	EA	12,000 LBS	250616L
5/8"	7.49 LBS	EA	18,100 LBS	250620L
3/4"	13.70 LBS	EA	28,300 LBS	250624L
7/8"	15.65 LBS	EA	34,200 LBS	250628L

CLEVIS SLIP HOOK (DOMESTIC)

**GRADE 80/100, ALLOY STEEL, QUENCHED & TEMPERED
FOR OVERHEAD LIFTING**



SIZE	WEIGHT	UNIT	WORKING LOAD LIMIT	STOCK NO.
1/4"	1.05 LBS	EA	4,500 LBS	250608C
3/8"	2.25 LBS	EA	7,100 LBS	250612C
1/2"	4.25 LBS	EA	12,000 LBS	250616C
5/8"	7.50 LBS	EA	18,100 LBS	250620C
3/4"	13.70 LBS	EA	28,300 LBS	250624C
7/8"	17.00 LBS	EA	34,200 LBS	250628C

WARNING

To prevent the possibility of serious bodily injury:
• **DO NOT EXCEED** the working load limits

HOOKS

EYE SLING HOOK FORGED STEEL, GRADE 80, ALLOY

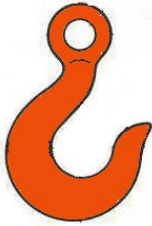

SIZE	PART NO.	WEIGHT	UNIT	WORKING LOAD LIMIT	STOCK NO.
1/4"	WA-30	0.80 LBS	EA	3,500 LBS	252008
3/8"	WA-31	2.10 LBS	EA	7,100 LBS	252012
1/2"	WA-32	3.65 LBS	EA	12,000 LBS	252016
5/8"	WA-33	6.40 LBS	EA	18,100 LBS	252020
3/4"	WA-34	9.80 LBS	EA	28,300 LBS	252024
7/8"	WA-35	15.40 LBS	EA	34,200 LBS	252028

EYE SLING HOOK WITH LATCH FORGED STEEL, GRADE 80, ALLOY



SIZE	PART NO.	WEIGHT	UNIT	WORKING LOAD LIMIT	STOCK NO.
1/4"	WA-30	0.80 LBS	EA	3,500 LBS	252008L
3/8"	WA-31	2.10 LBS	EA	7,100 LBS	252012L
1/2"	WA-32	3.65 LBS	EA	12,000 LBS	252016L
5/8"	WA-33	6.40 LBS	EA	18,100 LBS	252020L
3/4"	WA-34	9.80 LBS	EA	28,300 LBS	252024L
7/8"	WA-35	15.40 LBS	EA	34,200 LBS	252028L

ALLOY EYE FOUNDRY HOOK



SIZE	WEIGHT	UNIT	WORKING LOAD LIMIT	STOCK NO.
1/4"	2.40 LBS	EA	3,500 LBS	252808
3/8"	4.50 LBS	EA	7,100 LBS	252812
1/2"	7.10 LBS	EA	12,000 LBS	252816
5/8"	12.20 LBS	EA	18,100 LBS	252820
3/4"	19.30 LBS	EA	28,300 LBS	252824

WARNING

To prevent the possibility of serious bodily injury:
 • **DO NOT EXCEED** the working load limits

HOOKS

CLEVIS GRAB HOOK

G 80, ALLOY STEEL, QUENCHED & TEMPERED



SIZE	WEIGHT	UNIT	WORKING LOAD LIMIT	STOCK NO.
1/4"	0.64 LBS	EA	3,500 LBS	250408
5/16"	0.95 LBS	EA	4,500 LBS	250410
3/8"	1.25 LBS	EA	7,100 LBS	250412
1/2"	3.45 LBS	EA	12000 LBS	250416
5/8"	5.65 LBS	EA	18,100 LBS	250420
3/4"	10.60 LBS	EA	28,300 LBS	250424
7/8"	13.60 LBS	EA	34,200 LBS	250428

CLEVIS GRAB HOOK (DOMESTIC)

G80, ALLOY, FORGED STEEL, HEAT TREATED



SIZE	WEIGHT	UNIT	WORKING LOAD LIMIT	STOCK NO.
1/4"	0.64 LBS	EA	3,500 LBS	250408C
3/8"	1.25 LBS	EA	7,100 LBS	250412C
1/2"	3.45 LBS	EA	12,000 LBS	250416C
5/8"	5.65 LBS	EA	18,100 LBS	250420C
3/4"	10.60 LBS	EA	28,300 LBS	250424C
7/8"	13.60 LBS	EA	34,200 LBS	250428C

CLEVIS GRAB HOOK

G100, ALLOY, QUENCHED & TEMPERED



SIZE	WEIGHT	UNIT	WORKING LOAD LIMIT	STOCK NO.
1/4"	0.64 LBS	EA	4,300 LBS	250458
5/16"	0.61 LBS	EA	5,700 LBS	250460
3/8"	1.54 LBS	EA	8,800 LBS	250462
1/2"	3.41 LBS	EA	15,000 LBS	250466
5/8"	6.06 LBS	EA	22,600 LBS	250470
3/4"	9.25 LBS	EA	35,300 LBS	250474

WARNING

To prevent the possibility of serious bodily injury:
 • **DO NOT EXCEED** the working load limits

HOOKS

ALLOY EYE GRAB HOOK



SIZE	WEIGHT	UNIT	WORKING LOAD LIMIT	STOCK NO.
9/32"	0.65 LBS	EA	3,500 LBS	251408W
3/8"	1.30 LBS	EA	7,100 LBS	251412W
1/2"	2.73 LBS	EA	12,000 LBS	251416W
5/8"	4.65 LBS	EA	18,100 LBS	251420W
7/8"	13.00 LBS	EA	34,200 LBS	251428W



J HOOK, ALLOY (DOMESTIC)

SIZE	WEIGHT	UNIT	WORKING LOAD LIMIT	STOCK NO.
3/8"	0.25 LBS	EA	350 LBS	254083
7/16"	0.50 LBS	EA	500 LBS	254084
1/2"	1.00 LBS	EA	650 LBS	254086

BARREL HOOKS



SIZE	DESCRIPTION	WEIGHT	UNIT	WORKING LOAD LIMIT	STOCK NO.
1 TON	BARRELL HOOKS	3.60 LBS	PR	1 TON	260200

ALLOY WELD ON HOOK



SIZE	WEIGHT	UNIT	WORKING LOAD LIMIT	STOCK NO.
3 TON	2.90 LBS	EA	3 TON	265109
5 TON	4.60 LBS	EA	5 TON	265110
8 TON	8.20 LBS	EA	8 TON	265110.08
10 TON	11.0 LBS	EA	10 TON	265111

WARNING

To prevent the possibility of serious bodily injury:
 • **DO NOT EXCEED** the working load limits

HOOKS

REVERSE EYE HOOK (DOMESTIC) (NO LATCH BARB)



SIZE	WEIGHT	UNIT	WORKING LOAD LIMIT	STOCK NO.
1 TON	0.50 LBS	EA	1 TON	257003
1 1/2 TON	0.75 LBS	EA	1 1/2 TON	257004
3 TON	1.70 LBS	EA	3 TON	257007
4 1/2 TON	3.50 LBS	EA	4 1/2 TON	257009
11 TON	13.00 LBS	EA	11 TON	257015
15 TON	19.25 LBS	EA	15 TON	257017

TRAILER SAFETY S-HOOK



SIZE	WEIGHT	UNIT	WORKING LOAD LIMIT	STOCK NO.
3/8"	0.25 LBS	EA	750 LBS	144205
13/32"	0.30 LBS	EA	875 LBS	144210
7/16"	0.40 LBS	EA	1,250 LBS	144215
17/32"	0.56 LBS	EA	1,900 LBS	144218

S HOOK



SIZE	WEIGHT	UNIT	WORKING LOAD LIMIT	STOCK NO.
1/16"	0.002 LBS	EA	2 LBS	656202
3/32"	0.004 LBS	EA	7 LBS	656203
1/8"	0.004 LBS	EA	17 LBS	656204
5/32"	0.008 LBS	EA	26 LBS	656205.1
3/16"	0.014 LBS	EA	40 LBS	656206
7/32"	0.022 LBS	EA	70 LBS	656207
1/4"	0.044 LBS	EA	70 LBS	656208
5/16"	0.050 LBS	EA	132 LBS	656210
3/8"	0.130 LBS	EA	170 LBS	656212



MIDGET TWITCH HOOK

SIZE	WEIGHT	UNIT	STOCK NO.
5/16" PIN	3.00 LBS	EA	263902

WARNING

To prevent the possibility of serious bodily injury:
 • **DO NOT EXCEED** the working load limits

HOOKS

GLOVE HOOK/STANDARD CHOKER



SIZE	WEIGHT	UNIT	WORKING LOAD LIMIT	STOCK NO.
3/8"-1/2"	2.25 LBS	EA	3,400 LBS	262612
5/8"	4.25 LBS	EA	5,100 LBS	262620
3/4"	5.35 LBS	EA	8,000 LBS	262624
7/8"	7.50 LBS	EA	10,000 LBS	262628
1"	10.00 LBS	EA	15,000 LBS	262632

LOGGING CHOKER HOOK



SIZE	DESCRIPTION	WEIGHT	UNIT	WORKING LOAD LIMIT	STOCK NO.
3/8"	LARGE,ALLOY	2.12 LBS	EA	6,600 LBS	263954

LOGGING CHOKER SLIDE HOOK



SIZE	DESCRIPTION	WEIGHT	UNIT	STOCK NO.
1/2" - 9/16"	MICRO-MIDGET	0.75 LBS	EA	263401
1/2" - 9/16"	MIDGET	1.50 LBS	EA	263402
5/8"	DWARF	3.25 LBS	EA	263403

LOGGING HOLDRITE HOOK SLEEVE TYPE, LARGE HOLE



SIZE	DESCRIPTION	WEIGHT	UNIT	STOCK NO.
9/16"	MIDGET	2.25 LBS	EA	263802
5/8"	DWARF	4.00 LBS	EA	263803

LOGGING HOLDRITE HOOK RING TYPE, SMALL HOLE



SIZE	DESCRIPTION	WEIGHT	UNIT	STOCK NO.
1/2"-9/16"	MIDGET	3.00 LBS	EA	263602
5/8"	DWARF	3.50 LBS	EA	263820

WARNING

To prevent the possibility of serious bodily injury:
 • **DO NOT EXCEED** the working load limits

LATCH KITS

HOOK LATCH KIT V4320



SIZE	WEIGHT	UNIT	STOCK NO.
3/4T CARBON/ 1T ALLOY	0.03 LBS	EA	269302
1T CARBON/ 1.5T ALLOY	0.04 LBS	EA	269303
1.5T CARBON/ 2T ALLOY	0.04 LBS	EA	269404
2T CARBON/ 3T ALLOY	0.06 LBS	EA	269405
3T CARBON/ 5T ALLOY	0.10 LBS	EA	269407
5T CARBON/ 7T ALLOY	0.15 LBS	EA	269410
7.5T CARBON/ 11T ALLOY	0.29 LBS	EA	269413
10T CARBON/ 15T ALLOY	0.33 LBS	EA	269414
15T CARBON/ 22T ALLOY	0.84 LBS	EA	269317

HOOK LATCH KIT V4055

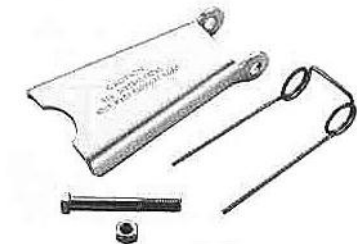

SIZE	WEIGHT	UNIT	STOCK NO.
3/4T CARBON/ 1T ALLOY	0.02 LBS	EA	269500
1T CARBON/ 1.5T ALLOY	0.02 LBS	EA	269501
1.5-2T CARBON/ 2-3T ALLOY	0.03 LBS	EA	269502
3T CARBON/ 4.5T ALLOY	0.06 LBS	EA	269503
5T CARBON/ 7T ALLOY	0.11 LBS	EA	269504
7.5-10T CARBON/ 11-15T ALLOY	0.17 LBS	EA	269505
15T CARBON/ 22T ALLOY	0.39 LBS	EA	269506
20T CARBON/ 30T ALLOY	0.63 LBS	EA	269507
25-30T CARBON/ 37-45T ALLOY	1.12 LBS	EA	269508
40T CARBON/ 60T ALLOY	1.77 LBS	EA	269509

HOOK LATCH KIT, FLAPPER

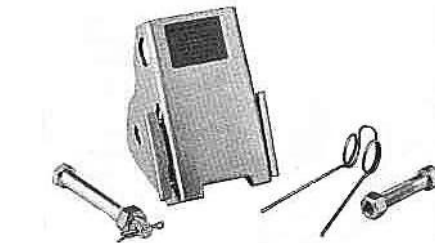

SIZE	WEIGHT	UNIT	STOCK NO.
3T CARBON/ 4.5T ALLOY	0.54 LBS	EA	269600
5T CARBON/ 7T ALLOY	0.66 LBS	EA	269601
7.5T CARBON/ 10T ALLOY	1.00 LBS	EA	269602
10T CARBON/ 15T ALLOY	1.25 LBS	EA	269603
15T CARBON/ 22T ALLOY	2.96 LBS	EA	269604
20T CARBON/ 30T ALLOY	4.05 LBS	EA	269605

WARNING

To prevent the possibility of serious bodily injury:
 • DO NOT EXCEED the working load limits

LATCH KITS

HOOK LATCH KIT

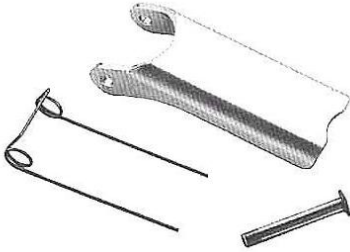

SIZE	DESCRIPTION	WEIGHT	UNIT	STOCK NO.
2\22	KIT 100/3.3	0.03 LBS	EA	269700
3\23	KIT 100/3.7	0.03 LBS	EA	269701
4\24	KIT 100/5	0.05 LBS	EA	269702
5\25	KIT 100/5.6	0.06 LBS	EA	269703
6\26	KIT 100/6.2	0.07 LBS	EA	269704
7\27	KIT 100/6.5	0.12 LBS	EA	269705
8\28	KIT 100/12	0.12 LBS	EA	269706
9\29	KIT 100/16.5	0.17 LBS	EA	269707
10\30	KIT 100/18.2	0.18 LBS	EA	269708
11\31	KIT 100/36	0.36 LBS	EA	269709
12\32	KIT 100/52	0.52 LBS	EA	269710
33	KIT #33	0.57 LBS	EA	269711
34	KIT #34	0.71 LBS	EA	269712
16\36	KIT #16-36	0.82 LBS	EA	269714

HOOK LATCH KIT

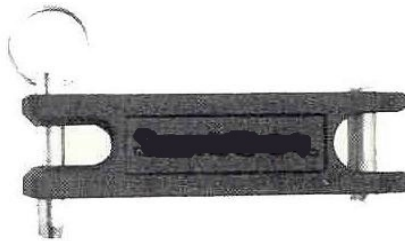

SIZE	DESCRIPTION	WEIGHT	UNIT	STOCK NO.
5 TON	KIT A5J	0.30 LBS	EA	269781
7 TON	KIT A7J	0.60 LBS	EA	269783
15 TON	KIT A15J	0.85 LBS	EA	269784
22 TON	KIT A22J	1.00 LBS	EA	269786
30 TON	KIT A30J	2.00 LBS	EA	269787
40 TON	KIT A40J	4.35 LBS	EA	269788
45 TON	KIT A45J	6.40 LBS	EA	269789
70 TON	KIT A70J	7.25 LBS	EA	269790
75-110 TON	KIT A75-110J	8.00 LBS	EA	269793
130-165 TON	KIT A130-165J	8.00 LBS	EA	269795

HOOK LATCH KIT CM

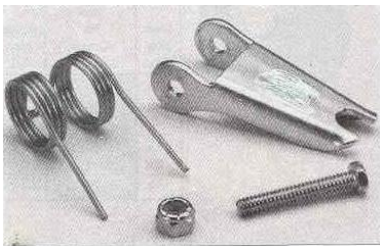

SIZE	DESCRIPTION	WEIGHT	UNIT	STOCK NO.
#4	KIT 4X1304	0.20 LBS	EA	269901
#6-7	KIT 4X1306	0.20 LBS	EA	269902
#5	KIT 4X1305	0.20 LBS	EA	269904
#7	KIT 4X1307	0.20 LBS	EA	269906
#9	KIT #9	0.20 LBS	EA	269903
#11	KIT 4X1311	0.25 LBS	EA	269911
#13	KIT 4X1313	0.25 LBS	EA	269913

WARNING

To prevent the possibility of serious bodily injury:
 • DO NOT EXCEED the working load limits

LATCH KITS

HOOK LATCH KIT, COLLAR STYLE



SIZE	WEIGHT	UNIT	STOCK NO.
B	0.10 LBS	EA	269801
C	0.15 LBS	EA	269802
D	0.15 LBS	EA	269803
E	0.20 LBS	EA	269804
F	0.25 LBS	EA	269805
G	0.30 LBS	EA	269806
H	0.38 LBS	EA	269807
J	0.42 LBS	EA	269809
K	0.47 LBS	EA	269810
L	0.51 LBS	EA	269811
M	0.56 LBS	EA	269812
O	0.60 LBS	EA	269814

RIGGING HOOK LATCH KIT CM



SIZE	DESCRIPTION	WEIGHT	UNIT	STOCK NO.
1/2 TON	KIT 4X404	0.08 LBS	EA	269920
1 TON	KIT 4X405	0.10 LBS	EA	269921
2 TON	KIT 4X406	0.15 LBS	EA	269922
3 TON	KIT 4X410	0.50 LBS	EA	269924
5 TON	KIT 4X412	0.70 LBS	EA	269923
7 1/2 TON	KIT 4X414	1.10 LBS	EA	269925

BRASS LATCH KIT (WEISSENFELS STYLE)

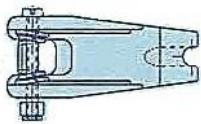

SIZE	WEIGHT	UNIT	STOCK NO.
1/4"	0.10 LBS	EA	269108
3/8"	0.20 LBS	EA	269112
1/2"	0.25 LBS	EA	269116
5/8"	0.25 LBS	EA	269120
3/4"	0.50 LBS	EA	269124

WARNING

To prevent the possibility of serious bodily injury:
 • **DO NOT EXCEED** the working load limits

EYE BOLTS

REGULAR NUT EYE BOLT H.D. GALVANIZED



SIZE	WEIGHT	UNIT	WORKING LOAD LIMIT*	STOCK NO.
1/4" X 2"	0.08 LBS	EA	500 LBS	19500802
1/4" X 3"	0.10 LBS	EA	500 LBS	19500803
1/4" X 4"	0.12 LBS	EA	500 LBS	19500804
1/4" X 5"	0.12 LBS	EA	500 LBS	19500805
1/4" X 6"	0.14 LBS	EA	500 LBS	19500806
5/16" X 2 1/4"	0.13 LBS	EA	800 LBS	19501002.25
5/16" X 2 1/2"	0.14 LBS	EA	800 LBS	19501002.5
5/16" X 3"	0.15 LBS	EA	800 LBS	19501003
5/16" X 3 1/4"	0.16 LBS	EA	800 LBS	19501003.25
5/16" X 4"	0.17 LBS	EA	800 LBS	19501004
5/16" X 4 1/4"	0.25 LBS	EA	800 LBS	19501004.25
5/16" X 4 1/2"	0.25 LBS	EA	800 LBS	19501004.5
5/16" X 6"	0.25 LBS	EA	800 LBS	19501006
3/8" X 2 1/2"	0.23 LBS	EA	1,200 LBS	19501202.5
3/8" X 3"	0.24 LBS	EA	1,200 LBS	19501203
3/8" X 3 1/2"	0.25 LBS	EA	1,200 LBS	19501203.5
3/8" X 4"	0.29 LBS	EA	1,200 LBS	19501204
3/8" X 4 1/2"	0.30 LBS	EA	1,200 LBS	19501204.5
3/8" X 6"	0.35 LBS	EA	1,200 LBS	19501206
3/8" X 8"	0.37 LBS	EA	1,200 LBS	19501208
3/8" X 10"	0.40 LBS	EA	1,200 LBS	19501210
3/8" X 12"	0.45 LBS	EA	1,200 LBS	19501212
3/8" X 18"	0.50 LBS	EA	1,200 LBS	19501218
1/2" X 2"	0.04 LBS	EA	2,200 LBS	19501602
1/2" X 3"	0.45 LBS	EA	2,200 LBS	19501603
1/2" X 3 1/4"	0.46 LBS	EA	2,200 LBS	19501603.25
1/2" X 4"	0.50 LBS	EA	2,200 LBS	19501604
1/2" X 4 1/2"	0.53 LBS	EA	2,200 LBS	19501604.5
1/2" X 6"	0.66 LBS	EA	2,200 LBS	19501606
1/2" X 8"	0.82 LBS	EA	2,200 LBS	19501608
1/2" X 10"	0.88 LBS	EA	2,200 LBS	19501610
1/2" X 12"	0.96 LBS	EA	2,200 LBS	19501612

***RATED CAPACITY IS FOR STRAIGHT LIFTS. ANGLE LIFTS SHOULD BE AVOIDED. LOAD LIMITS ARE REDUCED BY 75% ON ANGLE LIFTS.**

WARNING

To prevent the possibility of serious bodily injury:
 • DO NOT EXCEED the working load limits

EYE BOLTS

REGULAR NUT EYE BOLT H.D. GALVANIZED



SIZE	WEIGHT	UNIT	WORKING LOAD LIMIT*	STOCK NO.
5/8" X 4"	1.03 LBS	EA	3,500 LBS	19502004
5/8" X 4 1/2"	1.05 LBS	EA	3,500 LBS	19502004.5
5/8" X 6"	1.18 LBS	EA	3,500 LBS	19502006
5/8" X 8"	1.35 LBS	EA	3,500 LBS	19502008
5/8" X 10"	1.53 LBS	EA	3,500 LBS	19502010
5/8" X 12"	1.76 LBS	EA	3,500 LBS	19502012
5/8" X 15"	2.01 LBS	EA	3,500 LBS	19502015
5/8" X 18"	2.50 LBS	EA	3,500 LBS	19502018
5/8" X 21"	2.48 LBS	EA	3,500 LBS	19502021
5/8" X 24"	2.80 LBS	EA	3,500 LBS	19502024
3/4" X 4"	1.68 LBS	EA	5,200 LBS	19502404
3/4" X 4 1/2"	1.68 LBS	EA	5,200 LBS	19502404.5
3/4" X 6"	1.86 LBS	EA	5,200 LBS	19502406
3/4" X 8"	2.08 LBS	EA	5,200 LBS	19502408
3/4" X 10"	2.35 LBS	EA	5,200 LBS	19502410
3/4" X 12"	2.58 LBS	EA	5,200 LBS	19502412
3/4" X 15"	2.98 LBS	EA	5,200 LBS	19502415
3/4" X 18"	3.00 LBS	EA	5,200 LBS	19502418
3/4" X 24"	3.69 LBS	EA	5,200 LBS	19502424
7/8" X 6"	2.70 LBS	EA	7,000 LBS	19502806
7/8" X 8"	3.00 LBS	EA	7,000 LBS	19502808
7/8" X 10"	3.50 LBS	EA	7,000 LBS	19502810
7/8" X 12"	4.00 LBS	EA	7,000 LBS	19502812
1" X 4"	2.50 LBS	EA	8,500 LBS	19503204
1" X 6"	4.21 LBS	EA	8,500 LBS	19503206
1" X 8"	4.50 LBS	EA	8,500 LBS	19503208
1" X 10"	5.00 LBS	EA	8,500 LBS	19503210
1" X 12"	5.40 LBS	EA	8,500 LBS	19503212
1" X 18"	6.50 LBS	EA	8,500 LBS	19503218
1" X 24"	7.60 LBS	EA	8,500 LBS	19503224
1 1/4" X 6"	5.00 LBS	EA	13,500 LBS	19504006
1 1/4" X 8"	7.00 LBS	EA	13,500 LBS	19504008
1 1/4" X 12"	9.00 LBS	EA	13,500 LBS	19504012
1 1/4" X 20"	12.00 LBS	EA	13,500 LBS	19504020
1 1/2" X 12"	10.80 LBS	EA	20,000 LBS	19504812

***RATED CAPACITY IS FOR STRAIGHT LIFTS. ANGLE LIFTS SHOULD BE AVOIDED. LOAD LIMITS ARE REDUCED BY 75% ON ANGLE LIFTS.**

WARNING

To prevent the possibility of serious bodily injury:
*** DO NOT EXCEED** the working load limits

EYE BOLTS

MACHINE EYE BOLT SELF-COLORED



SIZE	WEIGHT	UNIT	WORKING LOAD LIMIT*	STOCK NO.
1/4" - 20	0.06 LBS	EA	500 LBS	1930081
5/16" - 18	0.11 LBS	EA	900 LBS	1930101
3/8" - 16	0.18 LBS	EA	1,200 LBS	1930121
7/16" - 14	0.23 LBS	EA	1,800 LBS	1930141
1/2" - 13	0.35 LBS	EA	2,200 LBS	1930161
9/16" - 12	0.47 LBS	EA	3,200 LBS	1930181
5/8" - 11	0.70 LBS	EA	3,500 LBS	1930201
3/4" - 10	1.10 LBS	EA	5,000 LBS	1930241
7/8" - 9	1.70 LBS	EA	7,000 LBS	1930281
1" - 8	2.36 LBS	EA	9,000 LBS	1930321
1 1/8" - 7	3.40 LBS	EA	12,000 LBS	1930361
1 1/4" - 7	4.68 LBS	EA	15,000 LBS	1930401
1 3/8" - 8	5.52 LBS	EA	17,000 LBS	1930441
1 1/2" - 6	7.77 LBS	EA	21,000 LBS	1930481
1 3/4" - 5	11.35 LBS	EA	28,000 LBS	1930561
2" - 5	16.70 LBS	EA	38,000 LBS	1930641

MACHINE EYE BOLT ZINC PLATED



SIZE	WEIGHT	UNIT	WORKING LOAD LIMIT*	STOCK NO.
3/8"	0.18 LBS	EA	1,300 LBS	192012
1/2"	0.35 LBS	EA	2,400 LBS	192016
5/8"	0.70 LBS	EA	4,000 LBS	192020
3/4"	1.10 LBS	EA	5,000 LBS	192024
7/8"	1.70 LBS	EA	7,000 LBS	192028
1"	2.36 LBS	EA	9,000 LBS	192032

METRIC MACHINE EYE BOLT SELF-COLORED



SIZE	WEIGHT	UNIT	WORKING LOAD LIMIT*	STOCK NO.
6 MM	0.06 LBS	EA	462 LBS	1935061
7 MM	0.10 LBS	EA	814 LBS	1935071
8 MM	0.17 LBS	EA	1,110 LBS	1935081
10 MM	0.24 LBS	EA	1,628 LBS	1935101
12 MM	0.36 LBS	EA	2,266 LBS	1935121
14 MM	0.48 LBS	EA	3,520 LBS	1935141
16 MM	0.69 LBS	EA	3,520 LBS	1935161
18 MM	1.10 LBS	EA	4,708 LBS	1935181
20 MM	1.51 LBS	EA	6,292 LBS	1935201
24 MM	2.36 LBS	EA	8,470 LBS	1935241
27 MM	3.41 LBS	EA	11,440 LBS	1935271

***RATED CAPACITY IS FOR STRAIGHT LIFTS. ANGLE LIFTS SHOULD BE AVOIDED. LOAD LIMITS ARE REDUCED BY 75% ON ANGLE LIFTS.**

WARNING

To prevent the possibility of serious bodily injury:
*** DO NOT EXCEED** the working load limits

EYE BOLTS

SHOULDER NUT EYE BOLT HD GALVANIZED



SIZE	WEIGHT	UNIT	WORKING LOAD LIMIT*	STOCK NO.
1/4" X 2"	0.066 LBS	EA	500 LBS	19800802
5/16" X 2 1/4"	0.12 LBS	EA	800 LBS	19801002.25
5/16" X 4 1/4"	0.19 LBS	EA	800 LBS	19801004.25
3/8" X 2 1/2"	0.21 LBS	EA	1,200 LBS	19801202.5
3/8" X 4 1/4"	0.25 LBS	EA	1,200 LBS	19801204.25
3/8" X 4 1/2"	0.25 LBS	EA	1,200 LBS	19801204.5
1/2" X 2"	0.42 LBS	EA	2,200 LBS	19801602
1/2" X 3 1/4"	0.43 LBS	EA	2,200 LBS	19801603.25
1/2" X 4"	0.56 LBS	EA	2,200 LBS	19801604
1/2" X 6"	0.58 LBS	EA	2,200 LBS	19801606
5/8" X 4"	0.69 LBS	EA	3,500 LBS	19802004
5/8" X 4 1/2"	0.70 LBS	EA	3,500 LBS	19802004.5
5/8" X 6"	1.02 LBS	EA	3,500 LBS	19802006
3/4" X 3 1/2"	1.40 LBS	EA	5,200 LBS	19802403.5
3/4" X 4 1/2"	1.44 LBS	EA	5,200 LBS	19802404.5
3/4" X 6"	1.67 LBS	EA	5,200 LBS	19802406
1" X 4"	3.45 LBS	EA	10,000 LBS	19803204
1" X 6"	3.66 LBS	EA	10,000 LBS	19803206
1 1/2" X 15"	14.25 LBS	EA	21,400 LBS	19804815

***RATED CAPACITY IS FOR STRAIGHT LIFTS. ANGLE LIFTS SHOULD BE AVOIDED.
LOAD LIMITS ARE REDUCED BY 75% ON ANGLE LIFTS.**

LAG SCREW EYE BOLTS – HD GALVANIZED



SIZE	WEIGHT	UNIT	STOCK NO.
1/4" X 1"	0.03LBS	EA	213407
1/4" X 2"	0.04 LBS	EA	213408
5/16" X 2 1/4"	0.10 LBS	EA	213410
3/8" X 2 1/2"	0.19 LBS	EA	213412
1/2" X 3 1/4"	0.37 LBS	EA	213416
5/8" X 4 1/2"	0.87 LBS	EA	213420
3/4" X 4 1/2"	0.90 LBS	EA	213424
1" X 6"	1.25 LBS	EA	213432

WARNING

To prevent the possibility of serious bodily injury:
• **DO NOT EXCEED** the working load limits

TURNBUCKLES



HOOK & HOOK

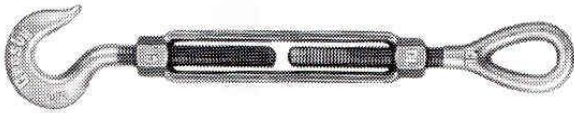

HOOK & EYE



EYE & EYE

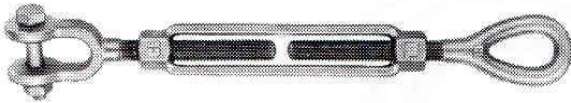

JAW & EYE

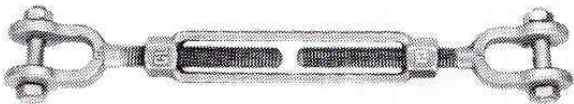

JAW & JAW



STUB END

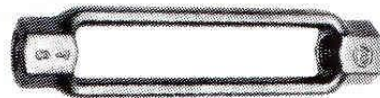

BODY ONLY

TURNBUCKLES

HOOK & HOOK (INTERNATIONAL) HD GALVANIZED



SIZE	WEIGHT	UNIT	WORKING LOAD LIMIT	STOCK NO.	SIZE	WEIGHT	UNIT	WORKING LOAD LIMIT	STOCK NO.
1/4" X 4"	0.35 LBS	EA	400 LBS	950104	3/4" X 6"	3.89 LBS	EA	3,000 LBS	955106
5/16" X 4.5"	0.47 LBS	EA	700 LBS	951104	3/4" X 9"	5.28 LBS	EA	3,000 LBS	955109
3/8" X 6"	0.78 LBS	EA	1,000 LBS	952106	3/4" X 12"	5.43 LBS	EA	3,000 LBS	955112
1/2" X 6"	1.60 LBS	EA	1,500 LBS	953106	3/4" X 18"	6.33 LBS	EA	3,000 LBS	955118
1/2" X 9"	1.85 LBS	EA	1,500 LBS	953109	7/8" X 12"	8.10 LBS	EA	4,000 LBS	956112
1/2" X 12"	2.28 LBS	EA	1,500 LBS	953112	7/8" X 18"	9.95 LBS	EA	4,000 LBS	956118
5/8" X 6"	2.75 LBS	EA	2,250 LBS	954106	1" X 12"	11.93 LBS	EA	5,000 LBS	957112
5/8" X 9"	3.38 LBS	EA	2,250 LBS	954109	1" X 18"	14.00 LBS	EA	5,000 LBS	957118
5/8" X 12"	3.50 LBS	EA	2,250 LBS	954112	1" X 24"	17.25 LBS	EA	5,000 LBS	957124

HOOK & EYE (INTERNATIONAL) HD GALVANIZED



SIZE	WEIGHT	UNIT	WORKING LOAD LIMIT	STOCK NO.	SIZE	WEIGHT	UNIT	WORKING LOAD LIMIT	STOCK NO.
1/4" X 4"	0.31 LBS	EA	400LBS	950204	3/4" X 6"	3.89 LBS	EA	3,000 LBS	955206
5/16" X 4.5"	0.47 LBS	EA	700 LBS	951204	3/4" X 9"	5.28 LBS	EA	3,000 LBS	955209
3/8" X 6"	0.78 LBS	EA	1,000 LBS	952206	3/4" X 12"	5.43 LBS	EA	3,000 LBS	955212
1/2" X 6"	1.60 LBS	EA	1,500 LBS	953206	3/4" X 18"	6.33 LBS	EA	3,000 LBS	955218
1/2" X 9"	1.85 LBS	EA	1,500 LBS	953209	7/8" X 12"	8.10 LBS	EA	4,000 LBS	956212
1/2" X 12"	2.28 LBS	EA	1,500 LBS	953212	7/8" X 18"	9.95 LBS	EA	4,000 LBS	956218
5/8" X 6"	2.75 LBS	EA	2,250 LBS	954206	1" X 12"	11.93 LBS	EA	5,000 LBS	957212
5/8" X 9"	3.38 LBS	EA	2,250 LBS	954209	1" X 18"	14.00 LBS	EA	5,000 LBS	957218
5/8" X 12"	3.50 LBS	EA	2,250 LBS	954212	1" X 24"	17.25 LBS	EA	5,000 LBS	957224

WARNING

To prevent the possibility of serious bodily injury:
 • **DO NOT EXCEED** the working load limits

TURNBUCKLES

EYE & EYE (INTERNATIONAL) HD GALVANIZED



SIZE	WEIGHT	UNIT	WORKING LOAD LIMIT	STOCK NO.	SIZE	WEIGHT	UNIT	WORKING LOAD LIMIT	STOCK NO.
1/4" X 4"	0.30 LBS	EA	500 LBS	950304	3/4" X 18"	6.33 LBS	EA	5,200 LBS	955318
5/16" X 4.5"	0.45 LBS	EA	800 LBS	951304	7/8" X 12"	8.10 LBS	EA	7,200 LBS	956312
3/8" X 6"	0.76 LBS	EA	1,200 LBS	952306	7/8" X 18"	9.95 LBS	EA	7,200 LBS	956318
1/2" X 6"	1.60 LBS	EA	2,200 LBS	953306	1" X 12"	11.93 LBS	EA	10,000 LBS	957312
1/2" X 9"	1.83 LBS	EA	2,200 LBS	953309	1" X 18"	14.00 LBS	EA	10,000 LBS	957318
1/2" X 12"	2.26 LBS	EA	2,200 LBS	953312	1" X 24"	17.25 LBS	EA	10,000 LBS	957324
5/8" X 6"	2.75 LBS	EA	3,500 LBS	954306	1-1/4" X 12"	20.55 LBS	EA	15,200 LBS	958312
5/8" X 9"	3.38 LBS	EA	3,500 LBS	954309	1-1/4" X 18"	23.00 LBS	EA	15,200 LBS	958318
5/8" X 12"	3.50 LBS	EA	3,500 LBS	954312	1-1/2" X 12"	27.50 LBS	EA	21,400 LBS	959312
3/4" X 6"	3.89 LBS	EA	5,200 LBS	955306	1-1/2" X 18"	31.00 LBS	EA	21,400 LBS	959318
3/4" X 9"	5.28 LBS	EA	5,200 LBS	955309	1-1/2" X 24"	37.50 LBS	EA	21,400 LBS	959324
3/4" X 12"	5.43 LBS	EA	5,200 LBS	955312	1-3/4" X 18"	52.50 LBS	EA	28,000 LBS	959906

JAW & EYE (INTERNATIONAL) HD GALVANIZED



SIZE	WEIGHT	UNIT	WORKING LOAD LIMIT	STOCK NO.	SIZE	WEIGHT	UNIT	WORKING LOAD LIMIT	STOCK NO.
1/4" X 4"	0.31 LBS	EA	500 LBS	950404	7/8" X 12"	8.36 LBS	EA	7,200 LBS	956412
5/16" X 4.5"	0.50 LBS	EA	800 LBS	951404	7/8" X 18"	9.75 LBS	EA	7,200 LBS	956418
3/8" X 6"	0.76 LBS	EA	1,200 LBS	952406	1" X 12"	11.20 LBS	EA	10,000 LBS	957412
1/2" X 6"	1.54 LBS	EA	2,200 LBS	953406	1" X 18"	13.30 LBS	EA	10,000 LBS	957418
1/2" X 9"	1.71 LBS	EA	2,200 LBS	953409	1" X 24"	17.00 LBS	EA	10,000 LBS	957424
1/2" X 12"	2.28 LBS	EA	2,200 LBS	953412	1-1/4" X 12"	19.42 LBS	EA	15,200 LBS	958412
5/8" X 6"	2.75 LBS	EA	3,500 LBS	954406	1-1/4" X 18"	24.18 LBS	EA	15,200 LBS	958418
5/8" X 9"	3.38 LBS	EA	3,500 LBS	954409	1-1/4" X 24"	28.50 LBS	EA	15,200 LBS	958424
5/8" X 12"	3.61 LBS	EA	3,500 LBS	954412	1-1/2" X 12"	28.50 LBS	EA	21,400 LBS	959412
3/4" X 6"	4.00 LBS	EA	5,200 LBS	955406	1-1/2" X 18"	35.00 LBS	EA	21,400 LBS	959418
3/4" X 9"	5.28 LBS	EA	5,200 LBS	955409	1-1/2" X 24"	39.18 LBS	EA	21,400 LBS	959424
3/4" X 12"	5.93 LBS	EA	5,200 LBS	955412	1-3/4" X 18"	53.75 LBS	EA	28,000 LBS	959901
3/4" X 18"	7.00 LBS	EA	5,200 LBS	955418	2" X 24"	89.00 LBS	EA	37,000 LBS	959912

WARNING

To prevent the possibility of serious bodily injury:
 * DO NOT EXCEED the working load limits

TURNBUCKLES

JAW & JAW (INTERNATIONAL) HD GALVANIZED

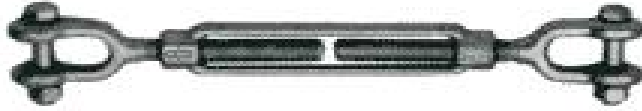

SIZE	WEIGHT	UNIT	WORKING LOAD LIMIT	STOCK NO.	SIZE	WEIGHT	UNIT	WORKING LOAD LIMIT	STOCK NO.
1/4" X 4"	0.38 LBS	EA	500 LBS	950504	1" X 12"	12.50 LBS	EA	10,000 LBS	957512
5/16" X 4.5"	0.52 LBS	EA	800 LBS	951504	1" X 18"	15.14 LBS	EA	10,000 LBS	957518
3/8" X 6"	0.81 LBS	EA	1,200 LBS	952506	1" X 24"	18.00 LBS	EA	10,000 LBS	957524
1/2" X 6"	1.56 LBS	EA	2,200 LBS	953506	1-1/4" X 12"	20.60 LBS	EA	15,200 LBS	958512
1/2" X 9"	1.74 LBS	EA	2,200 LBS	953509	1-1/4" X 18"	24.68 LBS	EA	15,200 LBS	958518
1/2" X 12"	2.40 LBS	EA	2,200 LBS	953512	1-1/4" X 24"	28.20 LBS	EA	15,200 LBS	958524
5/8" X 6"	2.75 LBS	EA	3,500 LBS	954506	1-1/2" X 6"	24.00 LBS	EA	21,400 LBS	959506
5/8" X 9"	3.43 LBS	EA	3,500 LBS	954509	1-1/2" X 12"	30.70 LBS	EA	21,400 LBS	959512
5/8" X 12"	3.91 LBS	EA	3,500 LBS	954512	1-1/2" X 18"	36.75 LBS	EA	21,400 LBS	959518
3/4" X 6"	4.11 LBS	EA	5,200 LBS	955506	1-1/2" X 24"	40.67 LBS	EA	21,400 LBS	959524
3/4" X 9"	5.46 LBS	EA	5,200 LBS	955509	1-3/4" X 18"	54.00 LBS	EA	28,000 LBS	959905
3/4" X 12"	6.43 LBS	EA	5,200 LBS	955512	1-3/4" X 24"	63.36 LBS	EA	28,000 LBS	9599319
3/4" X 18"	8.05 LBS	EA	5,200 LBS	955518	2" X 24"	94.25 LBS	EA	37,000 LBS	959911
7/8" X 12"	8.17 LBS	EA	7,200 LBS	956512	2-1/2" X 24"	165.00 LBS	EA	60,000 LBS	959908
7/8" X 18"	10.75 LBS	EA	7,200 LBS	956518	2-3/4" X 24"	198.00 LBS	EA	75,000 LBS	959909

STUB END (SELF-COLORED INTERNATIONAL)



SIZE	WEIGHT	UNIT	WORKING LOAD LIMIT	STOCK NO.
3/8" X 6"	0.75 LBS	EA	1,200 LBS	952606
1/2" X 6"	1.25 LBS	EA	2,200 LBS	953606
1/2" X 9"	1.50 LBS	EA	2,200 LBS	953609
5/8" X 6"	2.00 LBS	EA	3,500 LBS	954606
5/8" X 9"	2.50 LBS	EA	3,500 LBS	954609
5/8" X 12"	3.08 LBS	EA	3,500 LBS	954612
3/4" X 6"	3.25 LBS	EA	5,200 LBS	955606
3/4" X 9"	4.00 LBS	EA	5,200 LBS	955609
3/4" X 12"	4.68 LBS	EA	5,200 LBS	955612
7/8" X 6"	4.78 LBS	EA	7,200 LBS	956606
7/8" X 12"	6.35 LBS	EA	7,200 LBS	956612
1" X 6"	6.33 LBS	EA	10,000 LBS	957606
1" X 12"	8.93 LBS	EA	10,000 LBS	957612
1" X 24"	14.53 LBS	EA	10,000 LBS	957624
1 1/4" X 6"	10.18 LBS	EA	15,200 LBS	958606
1 1/4" X 12"	13.60 LBS	EA	15,200 LBS	958612
1 1/2" X 6"	15.10 LBS	EA	21,400 LBS	959606
1 1/2" X 12"	20.44 LBS	EA	21,400 LBS	959612

⚠ WARNING

To prevent the possibility of serious bodily injury:
 * **DO NOT EXCEED** the working load limits

TURNBUCKLES

TURNBUCKLE BODY (H.D. GALV. INTERNATIONAL)



SIZE	WEIGHT	UNIT	WORKING LOAD LIMIT	STOCK NO.
1/4" X 4"	0.15 LBS	EA	500 LBS	950704
3/8" X 6"	0.29 LBS	EA	1,200 LBS	952706
1/2" X 6"	0.60 LBS	EA	2,200 LBS	953706
1/2" X 9"	0.68 LBS	EA	2,200 LBS	953709
5/8" X 6"	0.90 LBS	EA	3,500 LBS	954706
5/8" X 9"	0.90 LBS	EA	3,500 LBS	954709
3/4" X 6"	1.30 LBS	EA	5,200 LBS	955706
3/4" X 12"	2.08 LBS	EA	5,200 LBS	955712
7/8" X 6"	1.13 LBS	EA	7,200 LBS	956706
7/8" X 12"	2.70 LBS	EA	7,200 LBS	956712
1" X 6"	2.48 LBS	EA	10,000 LBS	957706
1" X 12"	3.93 LBS	EA	10,000 LBS	957712

RATCHET



SIZE	TYPE	UNIT	WORKING LOAD LIMIT	STOCK NO.
1" X 12"	JAW & JAW	EA	13,000 LBS	95993712
1 3/8" X 12"	JAW & JAW	EA	28,300 LBS	959904
1 3/4" X 12"	JAW & JAW	EA	42,000 LBS	959904.5
1 3/4" X 18"	JAW & JAW	EA	42,000 LBS	95990418
1 3/4" X 24"	JAW & JAW	EA	42,000 LBS	95990424

WARNING

To prevent the possibility of serious bodily injury:
 * **DO NOT EXCEED** the working load limits

TURNBUCKLES

LASHING TURNBUCKLE SELF-COLORED

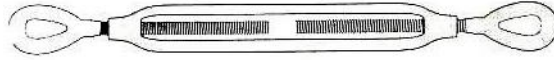

SIZE	WEIGHT	UNIT	WORKING LOAD	
			LIMIT	STOCK NO.
3/4" X 18"	8.00 LBS	EA	3,620 LBS	955314.1
1" X 18"	12.00 LBS	EA	6,620 LBS	957318.1

LIGHT DUTY ALUMINUM TURNBUCKLE

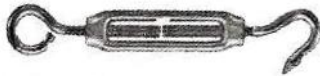

SIZE	TYPE	WEIGHT	UNIT	STOCK NO.
#8-32	EYE & EYE	0.04 LBS	EA	657200
#8-32	HOOK & EYE	0.04 LBS	EA	657201
#8-32	HOOK & HOOK	0.04 LBS	EA	657214
#10-24	EYE & EYE	0.05 LBS	EA	657202
#10-24	HOOK & EYE	0.05 LBS	EA	657203
#10-24	HOOK & HOOK	0.05 LBS	EA	657215
#12-24	EYE & EYE	0.07 LBS	EA	657206
#12-24	HOOK & EYE	0.07 LBS	EA	657207
#12-24	HOOK & HOOK	0.07 LBS	EA	657216
1/4"-20	EYE & EYE	0.13 LBS	EA	657208
1/4"-20	HOOK & EYE	0.13 LBS	EA	657209
1/4"-20	HOOK & HOOK	0.13 LBS	EA	657217
5/16"-18	EYE & EYE	0.21 LBS	EA	657210
5/16"-18	HOOK & EYE	0.21 LBS	EA	657211
5/16"-18	HOOK & HOOK	0.21 LBS	EA	657218
3/8"-16	EYE & EYE	0.36 LBS	EA	657212
3/8"-16	HOOK & EYE	0.36 LBS	EA	657213
3/8"-16	HOOK & HOOK	0.36 LBS	EA	657219
1/2" X 6"	HOOK & EYE	0.42 LBS	EA	657231
1/2" X 6"	EYE & EYE	0.40 LBS	EA	657232
1/2" X 6"	HOOK & HOOK	0.44 LBS	EA	657233

WARNING

To prevent the possibility of serious bodily injury:
 • **DO NOT EXCEED** the working load limits

STAINLESS STEEL
STAINLESS STEEL
STAINLESS STEEL

STAINLESS STEEL

WIRE ROPE

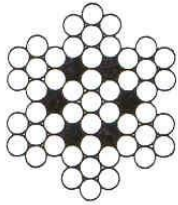

7 x 7

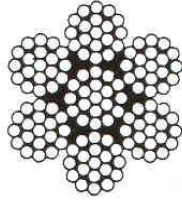

7 x 19

WIRE ROPE CLIPS

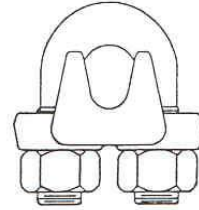

THIMBLES

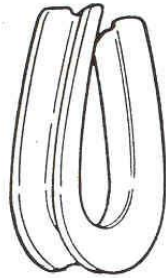

SHACKLES



TURNBUCKLES

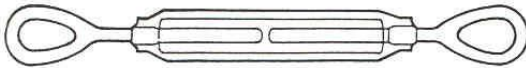

EYE & EYE

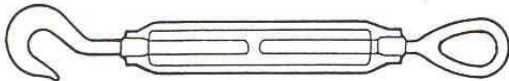

HOOK & EYE

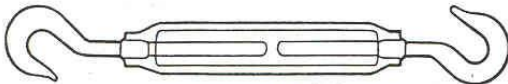

HOOK & HOOK

CHAIN

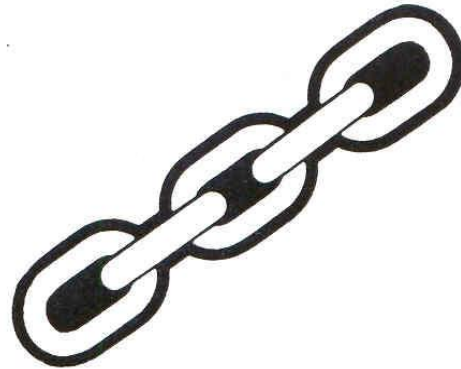

Consult your sales representative for stainless steel items not shown here.

STAINLESS STEEL

ARCHITECTURAL RAILING SYSTEM ASSEMBLIES

SAMPLE SELECTION OF VARIOUS ASSEMBLIES

TYPE 1

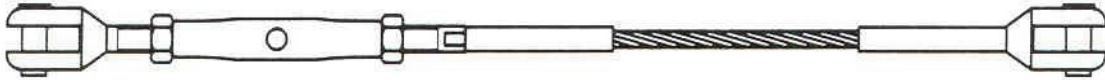

SWAGE ASSEMBLY COMPLETE WITH CLOSED BODY FORK, SWAGE TURNBUCKLES AND A SWAGE FORK FITTING. POINT TO POINT LENGTHS ARE REQUIRED TO FABRICATE.

TYPE 2



SWAGELESS ASSEMBLY WITH CLOSED BODY FORK, SWAGELESS TURNBUCKLE, AND A SWAGELESS FORK END. THESE TERMINALS CAN BE ASSEMBLED ON SITE, ALLOWING THE WIRE TO BE PASSED THROUGH ANY INTERMEDIATED POINT PRIOR TO TERMINATION. SWAGELESS FITTINGS CAN BE USED ON ASSEMBLIES WITH SWAGE FITTINGS ON ONE END FOR CUSTOM FIELD INSTALLATION.

TYPE 3



SWAGE WIRE ASSEMBLY USING SWAGE, TOGGLE TURNBUCKLE, AND A SWAGE TOGGLE FORK. TERMINALS THAT INCORPORATE A TOGGLE ARTICULATE IN BOTH DIRECTIONS, ALLOWING CABLE TO BE AT AN ANGLE TO TERMINAL POST. IDEAL FOR STAIRWAY RAILING.

TYPE 4



SWAGE ASSEMBLY WITH A SWAGE STUD FITTING AT EACH END. ALLOWING CABLE TENSIONING WITH LOW VISUAL IMPACT.

TYPE 5

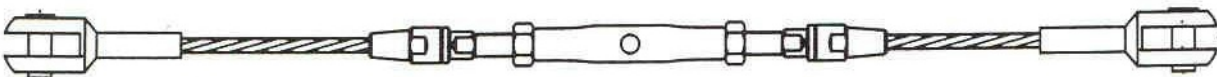

ASSEMBLY WITH TURNBUCKLE IN MID-SPAN, CAN BE CONSTRUCTED WITH EITHER SWAGE OR SWAGELESS FITTINGS.

***OTHER CUSTOM DESIGNS AVAILABLE.**

STAINLESS STEEL

TYPE 316 CHAIN

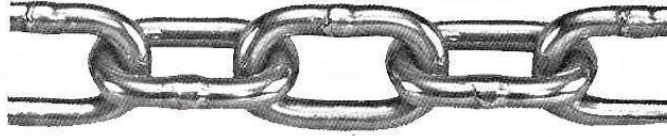

SIZE	WEIGHT	UNIT	STOCK NO.
1/8"	0.17 LBS/FT	FT	991504
3/16"	0.38 LBS/FT	FT	991506
1/4"	0.61 LBS/FT	FT	991509
5/16"	0.95 LBS/FT	FT	991510
3/8"	1.40 LBS/FT	FT	991513
1/2"	2.34 LBS/FT	FT	991517

TYPE 304 CHAIN

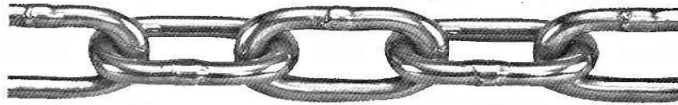

SIZE	TYPE	STANDARD	WEIGHT	UNIT	STOCK NO.
5/32"	PC	ASTM 80	0.20 LBS/FT	FT	991505
5/32"	HT	ASTM 80		FT	991555
1/4"	PC	ASTM 80	0.60 LBS/FT	FT	991508
1/4"	HT	ASTM 80		FT	991558
3/8"	PC	ASTM 80	1.38 LBS/FT	FT	991512
3/8"	HT	ASTM 80		FT	991562
1/2"	PC	ASTM 80	2.43 LBS/FT	FT	991516
1/2"	HT	ASTM 80		FT	991566

BOWTYE CHAIN

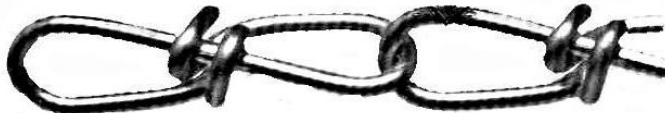

SIZE	WEIGHT	UNIT	STOCK NO.
#1	0.17 LBS/FT	FT	991501
#3	0.19 LBS/FT	FT	991503

WARNING

To prevent the possibility of serious bodily injury:

- **DO NOT EXCEED** the working load limits for chain or components.
- **DO NOT USE** for overhead lifting or hoisting.
- **DO NOT USE** if the chain or components are visibly distorted or worn.

STAINLESS STEEL

WIRE ROPE CLIP PRECISION CAST, D.F. STYLE



SIZE	WEIGHT	UNIT	STOCK NO.
1/16"	0.02 LBS	EA	992402
1/8"	0.04 LBS	EA	992404
3/16"	0.06 LBS	EA	992406
1/4"	0.10 LBS	EA	992408
5/16"	0.18 LBS	EA	992410
3/8"	0.35 LBS	EA	992412
1/2"	0.52 LBS	EA	992416
5/8"	0.89 LBS	EA	992420
3/4"	1.05 LBS	EA	992424



MALLEABLE CLIP

SIZE	WEIGHT	UNIT	STOCK NO.
1/8"	0.03 LBS	EA	992304
3/16"	0.06 LBS	EA	992306
1/4"	0.10 LBS	EA	992308
5/16"	0.18 LBS	EA	992310
3/8"	0.35 LBS	EA	992312
1/2"	0.52 LBS	EA	992316
5/8"	0.89 LBS	EA	992320



FIST GRIP CLIP

SIZE	WEIGHT	UNIT	STOCK NO.
5/16"	0.03 LBS	EA	992010

WARNING

To prevent the possibility of serious bodily injury:
• **DO NOT EXCEED** the working load limits

STAINLESS STEEL

MACHINE SHOULDER EYE BOLT



SIZE	WEIGHT	UNIT	WORKING LOAD LIMIT	STOCK NO.
1/4" - 20	0.05 LBS	EA	460 LBS	992508
5/16" - 18	0.10 LBS	EA	780 LBS	992510
3/8" - 16	0.20 LBS	EA	1,300 LBS	992512
1/2" - 13	0.42 LBS	EA	2,400 LBS	992516
5/8" - 11	0.70 LBS	EA	4,000 LBS	992520
3/4" - 10	1.08 LBS	EA	5,000 LBS	992524
1" - 8	2.46 LBS	EA	9,000 LBS	992532

REGULAR NUT EYEBOLT



SIZE	WEIGHT	UNIT	WORKING LOAD LIMIT	STOCK NO.
1/4" X 2"	0.25 LBS	EA	200 LBS	99250802
1/4" X 4"	0.09 LBS	EA	200 LBS	99250804
5/16" X 4"	0.15 LBS	EA	350 LBS	99251004
3/8" X 4"	0.20 LBS	EA	600 LBS	99251204
3/8" X 6"	0.30 LBS	EA	600 LBS	99251206
1/2" X 4"	0.54 LBS	EA	2,100 LBS	99251604
1/2" X 6"	0.58 LBS	EA	2,100 LBS	99251606
5/8" X 4"	0.47 LBS	EA	3,440 LBS	99252004
5/8" X 6"	1.10 LBS	EA	3,440 LBS	99252006
3/4" X 6"	1.80 LBS	EA	5,140 LBS	99252406
7/8" X 5"	2.75 LBS	EA	7,130 LBS	99252805

SHOULDER REGULAR NUT EYEBOLT



SIZE	WEIGHT	UNIT	STOCK NO.
1/4" X 2 1/4"	0.06 LBS	EA	99255802.25
3/8" X 2 1/2"	0.21 LBS	EA	99256202.5
3/8" X 4 3/4"	0.35 LBS	EA	99256204.75
1/2" X 3 1/4"	0.46 LBS	EA	99256603.25
1/2" X 4 3/4"	0.50 LBS	EA	99256604.75
1/2" X 6"	0.58 LBS	EA	99256606
5/8" X 4"	0.82 LBS	EA	99257004
5/8" X 6"	1.10 LBS	EA	99257006
3/4" X 6"	2.00 LBS	EA	99257406
1" X 6"	2.80 LBS	EA	99258206
1" X 9"	3.50 LBS	EA	99258209

WARNING

To prevent the possibility of serious bodily injury:
 • **DO NOT EXCEED** the working load limits

STAINLESS STEEL

EYE HOIST HOOK



SIZE	WEIGHT	UNIT	WORKING LOAD	
			LIMIT	STOCK NO.
1 TON	0.89 LBS	EA	1 TON	994001
1 1/2 TON	1.14 LBS	EA	1 1/2 TON	994011

SNAP HOOK



SIZE	WEIGHT	UNIT	STOCK NO.
3/4"	0.50 LBS	EA	994029
1 1/8"	0.60 LBS	EA	994030

SWIVEL EYE SNAP HOOK



SIZE	WEIGHT	UNIT	STOCK NO.
5/8"	0.25 LBS	EA	994039
3/4"	0.30 LBS	EA	994040
2 3/4"	0.20 LBS	EA	994048

MISSING LINK



SIZE	WEIGHT	UNIT	STOCK NO.
1/4"	0.063 LBS	EA	997508
5/16"	0.012 LBS	EA	997510
3/8"	0.20 LBS	EA	997512
1/2"	0.28 LBS	EA	997516

WARNING

To prevent the possibility of serious bodily injury:
 • **DO NOT EXCEED** the working load limits

STAINLESS STEEL

OBLONG MASTER LINK



SIZE	WEIGHT	UNIT	WORKING LOAD LIMIT	STOCK NO.
1/2"	0.85 LBS	EA	2,000 LBS	995616
5/8"	1.50 LBS	EA	3,000 LBS	995620
3/4"	2.65 LBS	EA	4,000 LBS	995624
1"	4.90 LBS	EA	8,000 LBS	995632

WELDED RING



SIZE	WEIGHT		UNIT	STOCK NUMBER	
	TYPE 316	TYPE 304		TYPE 316	TYPE 304
1/4" X 2"	0.09 LBS	0.09 LBS	EA	995643	995608
3/8" X 3"	0.39 LBS	0.38 LBS	EA	995645	995612
1/2" X 3"	0.56 LBS	0.56 LBS	EA	995646	995665
1/2" X 4"	0.71 LBS	0.71 LBS	EA	995647	995666
5/8" X 4"	1.34 LBS	1.34 LBS	EA	995648	995670
5/8" X 5"	1.63 LBS	1.63 LBS	EA	995649	995671

STAINLESS TIE WIRE

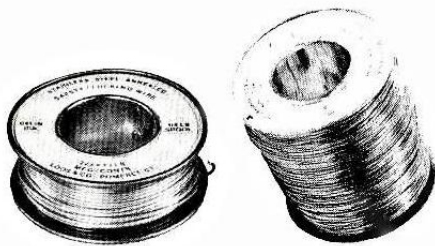

SIZE	DESCRIPTION	WEIGHT	UNIT	STOCK NO.
0.025	22 GAUGE	1.00 LBS	SPOOL	994004
0.047	16.5 GAUGE	1.00 LBS	SPOOL	994020
0.051	16 GAUGE	1.00 LBS	SPOOL	994616
0.040	18 GAUGE	5.00 LBS	SPOOL	994617
0.040	18 GAUGE	1.00 LBS	SPOOL	994618
0.041	17.75 GAUGE	1.00 LBS	SPOOL	994619
0.035	19 GAUGE	1.00 LBS	SPOOL	994620
0.032	20 GAUGE	1.00 LBS	SPOOL	994621

WARNING

To prevent the possibility of serious bodily injury:
 • DO NOT EXCEED the working load limits

STAINLESS STEEL

SCREW PIN ANCHOR SHACKLE



SIZE	WEIGHT	UNIT	WORKING LOAD LIMIT	STOCK NO.
1/4"	0.11 LBS	EA	1,000 LBS	996708
5/16"	0.18 LBS	EA	1,500 LBS	996710
3/8"	0.30 LBS	EA	2,000 LBS	996712
1/2"	0.67 LBS	EA	4,000 LBS	996716
5/8"	1.25 LBS	EA	6,000 LBS	996720
3/4"	2.00 LBS	EA	8,000 LBS	996724
7/8"	3.30 LBS	EA	10,000 LBS	996728
1"	4.6 LBS	EA	14,000 LBS	996732

QUICK LINK



SIZE	WEIGHT	UNIT	WORKING LOAD LIMIT	STOCK NO.
1/8"	0.02 LBS	EA	300 LBS	997104
3/16"	0.03 LBS	EA	800 LBS	997106
1/4"	0.05 LBS	EA	1,200 LBS	997108
5/16"	0.25 LBS	EA	2,000 LBS	997110
3/8"	0.33 LBS	EA	3,000 LBS	997112
1/2"	0.55 LBS	EA	5,000 LBS	997116

SPRING LINK



SIZE	WEIGHT	UNIT	STOCK NO.
3/16"	0.04 LBS	EA	997006
1/4"	0.06 LBS	EA	997008
5/16"	0.10 LBS	EA	997010
3/8"	0.15 LBS	EA	997012
1/2"	0.22 LBS	EA	997016

SWIVEL EYE & EYE (T304)



SIZE	WEIGHT	UNIT	STOCK NO.
1/4"	0.12 LBS	EA	997808
5/16"	0.29 LBS	EA	997810
3/8"	0.55 LBS	EA	997812
1/2"	1.25 LBS	EA	997816
5/8"	2.10 LBS	EA	997820
3/4"	3.5 LBS	EA	997824
7/8"	5.02 LBS	EA	997828
1"	8.73 LBS	EA	997832

WARNING

To prevent the possibility of serious bodily injury:
 • **DO NOT EXCEED** the working load limits

STAINLESS STEEL

CLEVIS GRAB HOOK STAINLESS STEEL T316



SIZE	WEIGHT	UNIT	WORKING LOAD LIMIT	STOCK NO.
1/4"	0.36 LBS	EA	1,250 LBS	990308
5/16"	0.65 LBS	EA	1,850 LBS	998310
3/8"	0.90 LBS	EA	2,500 LBS	998312
1/2"	1.95 LBS	EA	3,600 LBS	990316

CLEVIS SLIP HOOK STAINLESS STEEL T316



SIZE	DESCRIPTION	WEIGHT	UNIT	WORKING LOAD LIMIT	STOCK NO.
1/4"	PRECISION CAST NO LATCH	0.41 LBS	EA	960 LBS	990808
1/4"	WITH LATCH	0.42 LBS	EA	960 LBS	990808L
5/16"	PRECISION CAST NO LATCH	0.74 LBS	EA	1,250 LBS	990810
5/16"	WITH LATCH	0.76 LBS	EA	1,250 LBS	990810L
3/8"	PRECISION CAST NO LATCH	1.15 LBS	EA	2,000 LBS	990812
3/8"	WITH LATCH	1.18 LBS	EA	2,000 LBS	990812L
1/2"	PRECISION CAST NO LATCH	2.30 LBS	EA	3,000 LBS	990816
1/2"	WITH LATCH	2.36 LBS	EA	3,000 LBS	990816L

EYE GRAB HOOK STAINLESS STEEL T316



SIZE	WEIGHT	UNIT	WORKING LOAD LIMIT	STOCK NO.
1/4"	0.28 LBS	EA	1,200 LBS	991308
5/16"	0.50 LBS	EA	1,800 LBS	991310
3/8"	0.78 LBS	EA	2,500 LBS	991312
1/2"	1.60 LBS	EA	3,600 LBS	991316

EYE SLIP HOOK STAINLESS STEEL T316



SIZE	DESCRIPTION	WEIGHT	UNIT	WORKING LOAD LIMIT	STOCK NO.
1/4"	PRECISION CAST NO LATCH	0.35 LBS	EA	900 LBS	992208
1/4"	WITH LATCH	0.39 LBS	EA	900 LBS	992208L
5/16"	PRECISION CAST NO LATCH	0.55 LBS	EA	1,250 LBS	992210
5/16"	WITH LATCH	0.62 LBS	EA	1,250 LBS	992210L
3/8"	PRECISION CAST NO LATCH	0.90 LBS	EA	2,000 LBS	992212
3/8"	WITH LATCH	1.00 LBS	EA	2,000 LBS	992212L
1/2"	PRECISION CAST NO LATCH	1.90 LBS	EA	3,000 LBS	992216
1/2"	WITH LATCH	1.95 LBS	EA	3,000 LBS	992216L

⚠ WARNING

To prevent the possibility of serious bodily injury:
 • **DO NOT EXCEED** the working load limits

STAINLESS STEEL



LIGHT DUTY THIMBLE

SIZE	WEIGHT	UNIT	STOCK NO.
1/8"	0.01 LBS	EA	998504
5/32"	0.02 LBS	EA	998505
3/16"	0.04 LBS	EA	998506
1/4"	0.06 LBS	EA	998507
5/16"	0.10 LBS	EA	998509



HEAVY DUTY THIMBLE

SIZE	WEIGHT	UNIT	STOCK NO.
1/4"	0.08 LBS	EA	998508
5/16"	0.14 LBS	EA	998510
3/8"	0.25 LBS	EA	998512
1/2"	0.53 LBS	EA	998516
5/8"	0.70 LBS	EA	998520
3/4"	1.25 LBS	EA	998524
7/8"	1.46 LBS	EA	998528
1"	2.46 LBS	EA	998532

TURNBUCKLE



SIZE	DESCRIPTION	WEIGHT	UNIT	WORKING LOAD LIMIT	STOCK NO.
1/4" X 4"	EYE & EYE	0.39 LBS	EA	500 LBS	99900304
1/4" X 4"	JAW & JAW	0.60 LBS	EA	500 LBS	99900504
1/4" X 4"	JAW & EYE	0.60 LBS	EA	500 LBS	99900404
3/8" X 6"	EYE & EYE	0.60 LBS	EA	1,200 LBS	99902306
3/8" X 6"	JAW & EYE	0.85 LBS	EA	1,200 LBS	99902406
3/8" X 6"	JAW & JAW	0.85 LBS	EA	1,200 LBS	99902506
1/2" X 6"	EYE & EYE	1.40 LBS	EA	2,200 LBS	99903306
1/2" X 6"	JAW & EYE	1.51 LBS	EA	2,200 LBS	99903406
1/2" X 6"	JAW & JAW	1.64 LBS	EA	2,200 LBS	99903506
5/8" X 6"	JAW & JAW	2.75 LBS	EA	3,500 LBS	99904506
5/8" X 6"	EYE & EYE	2.75 LBS	EA	3,500 LBS	99904306
5/8" X 6"	JAW & EYE	2.75 LBS	EA	3,500 LBS	99904406
3/4" X 6"	JAW & EYE	4.50 LBS	EA	5,200 LBS	99905406
3/4" X 6"	EYE & EYE	3.90 LBS	EA	5,200 LBS	99905306
3/4" X 6"	JAW & JAW	4.50 LBS	EA	5,200 LBS	99905506

WARNING

To prevent the possibility of serious bodily injury:
 • DO NOT EXCEED the working load limits

STAINLESS STEEL

TURNBUCKLE BODY ONLY



SIZE	WEIGHT	UNIT	WORKING LOAD LIMIT	STOCK NO.
1/4" X 4"	0.20 LBS	EA	500 LBS	99900704
3/8" X 6"	0.30 LBS	EA	1,200 LBS	99902706
1/2" X 6"	.80 LBS	EA	2,200 LBS	99903706
5/8" X 6"	1.70 LBS	EA	3,500 LBS	99904709
3/4" X 6"	0.50 LBS	EA	5,200 LBS	99905706

TURNBUCKLE TOGGLE/SWAGE



SIZE	DESCRIPTION	WEIGHT	UNIT	STOCK NO.
1/4"	SWAGE/SWAGE	0.30 LBS	EA	99900604
5/16" X 4"	TOGGLE/SWAGE	0.50 LBS	EA	99901904
3/8" X 5"	TOGGLE/SWAGE	0.65 LBS	EA	99902905
1/2" X 6"	TOGGLE/SWAGE	0.80 LBS	EA	99903906

U-BOLT



SIZE	DESCRIPTION	WEIGHT	UNIT	STOCK NO.
1/4" X 1" X 1 3/4"	NO NUTS	0.10 LBS	EA	992707
1/4" X 2" X 3 1/4"	NO NUTS	0.10 LBS	EA	992708
3/8" X 1 1/2" X 2 1/2"	NO NUTS	0.25 LBS	EA	99271248
3/8" X 2 1/2" X 3 1/8"	NO NUTS	0.25 LBS	EA	99271280
3/8" X 3" X 3 5/8"	NO NUTS	0.25 LBS	EA	99271296
1/2" X 5 5/8" X 7"	WITH NUTS	0.30 LBS	EA	992716

WARNING

To prevent the possibility of serious bodily injury:
 • **DO NOT EXCEED** the working load limits

BLOCKS

SWIVEL EYE BLOCK



SIZE	DESCRIPTION	MAX WIRE ROPE SIZE	WEIGHT	UNT	WORKING LOAD	
					LIMIT	STOCK NO.
1 1/2"	SINGLE SHEAVE	3/16"	0.50 LBS	EA	420 LBS	120101I
2"	SINGLE SHEAVE	3/16"	0.70 LBS	EA	480 LBS	120102I
2 1/2"	SINGLE SHEAVE	1/4"	1.00 LBS	EA	550 LBS	120103I
3"	SINGLE SHEAVE	5/16"	1.40 LBS	EA	640 LBS	120104I
3 1/2"	SINGLE SHEAVE	3/8"	3.10 LBS	EA	1,240 LBS	120105I
4"	SINGLE SHEAVE	3/8"	3.60 LBS	EA	1,700 LBS	120106I
2"	DOUBLE SHEAVE	3/16"	1.50 LBS	EA	600 LBS	120202
2 1/2"	DOUBLE SHEAVE	1/4"	2.00 LBS	EA	685 LBS	120203
3 1/2"	DOUBLE SHEAVE	5/16"	5.00 LBS	EA	1,550 LBS	120205
4"	DOUBLE SHEAVE	3/8"	5.00 LBS	EA	1,550 LBS	120206

SWIVEL HOOK BLOCK



SIZE	DESCRIPTION	MAX WIRE ROPE SIZE	WEIGHT	UNT	WORKING LOAD LIMIT	STOCK NO.
1 1/2"	SINGLE SHEAVE	3/16"	0.50 LBS	EA	420 LBS	120701I
2"	SINGLE SHEAVE	3/16"	0.70 LBS	EA	480 LBS	120702I
2 1/2"	SINGLE SHEAVE	1/4"	1.00 LBS	EA	550 LBS	120703I
3"	SINGLE SHEAVE	5/16"	1.40 LBS	EA	640 LBS	120704I
3 1/2"	SINGLE SHEAVE	3/8"	3.10 LBS	EA	1,240 LBS	120705I
4"	SINGLE SHEAVE	3/8"	3.10 LBS	EA	1,700 LBS	120708I

FLAT BLOCKS – SINGLE SHEAVE



SIZE	DESCRIPTION	WEIGHT	UNT	WORKING LOAD	
				LIMIT	STOCK NO.
1 1/2"	#525-3/16" WR	0.30 LBS	EA	525 LBS	120301
2"	#600-3/16" WR	0.50 LBS	EA	600 LBS	120302
2 1/2"	#685-1/4" WR	0.80 LBS	EA	685 LBS	120303
3"	#800-5/16" WR	1.00 LBS	EA	800 LBS	120304
3 1/2"	#1550-3/8" WR	2.30 LBS	EA	1,550 LBS	120305

⚠ WARNING

To prevent the possibility of serious bodily injury:
 • **DO NOT EXCEED** the working load limits

BLOCKS



SNATCH BLOCK WITH HOOK (INTERNATIONAL)

SIZE	PART NO.	WEIGHT	UNIT	WORKING LOAD LIMIT	STOCK NO.
3"	V418	6.00 LBS	EA	2 TON	126303I
4 1/2"	V418	15.00 LBS	EA	4 TON	126304I
6"	V418	26.00 LBS	EA	8 TON	126306I
8"	V418	33.00 LBS	EA	8 TON	126308I



SNATCH BLOCK WITH HOOK (DOMESTIC)

SIZE	PART NO.	WEIGHT	UNIT	WORKING LOAD LIMIT	STOCK NO.
3"	V418	6.00 LBS	EA	2 TON	126303
4 1/2"	V418	15.00 LBS	EA	4 TON	126304
6"	V418	26.00 LBS	EA	8 TON	126306
8"	V418	33.00 LBS	EA	8 TON	126308
12"	V418	48.00 LBS	EA	8 TON	126312



SNATCH BLOCK WITH SHACKLE (INTERNATIONAL)

SIZE	PART NO.	WEIGHT	UNIT	WORKING LOAD LIMIT	STOCK NO.
3"	V419	3.00 LBS	EA	2 TON	126403I
4 1/2"	V419	12.00 LBS	EA	4 TON	126404I
6"	V419	27.00 LBS	EA	8 TON	126406I
8"	V419	34.00 LBS	EA	8 TON	126408I



SNATCH BLOCK WITH SHACKLE (DOMESTIC)

SIZE	PART NO.	WEIGHT	UNIT	WORKING LOAD LIMIT	STOCK NO.
3"	V419	3.00 LBS	EA	2 TON	126403
4 1/2"	V419	12.00 LBS	EA	4 TON	126404
6"	V419	27.00 LBS	EA	8 TON	126406
8"	V419	34.00 LBS	EA	8 TON	126408

WARNING

To prevent the possibility of serious bodily injury:
 • **DO NOT EXCEED** the working load limits

BLOCKS



SNATCH BLOCK ALL ALLOY

SIZE	WIRE ROPE SIZE	DESCRIPTION	WEIGHT	UNIT	WORKING LOAD LIMIT	STOCK NO.
6"	3/4" & 7/8"	WITH HOOK	26.00 LBS	EA	12 TON	126606
6"	3/4" & 7/8"	WITH SHACKLE	27.00 LBS	EA	12 TON	126706
8"	3/4" & 7/8"	WITH HOOK	33.00 LBS	EA	12 TON	126608
8"	3/4" & 7/8"	WITH SHACKLE	34.00 LBS	EA	12 TON	126708
10"	3/4" & 7/8"	WITH HOOK	41.00 LBS	EA	12 TON	126610
10"	3/4" & 7/8"	WITH SHACKLE	42.00 LBS	EA	12 TON	126710



SNATCH BLOCK-HEAVY DUTY (DOMESTIC)

SIZE	DESCRIPTION	WEIGHT	UNIT	WORKING LOAD LIMIT	STOCK NO.
12"	W/HOOK V416-12 BB	75.00 LBS	EA	12 TON	126612
10"	W/HOOK V430BB	89.00 LBS	EA	20 TON	125610
12"	W/HOOK V403BB	103.0 LBS	EA	20 TON	125612



SNATCH BLOCK DOUBLE

SIZE	DESCRIPTION	WEIGHT	UNIT	WORKING LOAD LIMIT	STOCK NO.
4 1/2"	W/SHACKLE V409	18.00 LBS	EA	4 TON	126204
4 1/2"	W/HOOK BB V408	18.00 LBS	EA	4 TON	126104
6"	W/HOOK BB V408	45.00 LBS	EA	12 TON	126106
6"	W/SHACKLE	45.00 LBS	EA	12 TON	126206

WARNING

To prevent the possibility of serious bodily injury:
 * DO NOT EXCEED the working load limits

BLOCKS

BLOCK TAILBOARD (INTERNATIONAL) BRONZE BUSHED SHEAVES, WITH GREASE FITTINGS



SIZE	WEIGHT	UNIT	WORKING LOAD LIMIT	STOCK NO.
3"	3.15 LBS	EA	4 TON	126503I
4 1/2"	7.92 LBS	EA	4 TON	126504I
6"	15.40 LBS	EA	12 TON	126506I
8"	24.20 LBS	EA	12 TON	126508I



YARDING BLOCK (HD GALVANIZED WITH GREASE FITTINGS)

SIZE	DESCRIPTION	WEIGHT	UNIT	WORKING LOAD LIMIT	STOCK NO.
3"	YARDING BLOCK	5.00 LBS	EA	1 1/2 TON	119901
4"	YARDING BLOCK	9.00 LBS	EA	3 TON	119902
5"	YARDING BLOCK	9.00 LBS	EA	4 1/2 TON	119903
6"	YARDING BLOCK	15.00 LBS	EA	6 TON	119904



RIGGING BLOCK (ELECTRO GALVANIZED, GREEN SHEAVE)

SIZE	DESCRIPTION	WEIGHT	UNIT	WORKING LOAD LIMIT	STOCK NO.
3"	SINGLE SHEAVE	2.64 LBS	EA	3/4 TON	119923
5"	SINGLE SHEAVE	7.45 LBS	EA	1.5 TON	119925

WARNING

To prevent the possibility of serious bodily injury:
 • **DO NOT EXCEED** the working load limits

BLOCKS

OVERHAUL BALL



SPLIT BALL

SIZE	DESCRIPTION	WEIGHT	UNIT	WORKING LOAD LIMIT	STOCK NO.
20 LB	SPLIT BALL OB20	20.00 LBS	EA	N/A	124199
50 LB	SPLIT BALL OB50	50.00 LBS	EA	N/A	124204
150 LB	OVERHAUL BALL OB7EE	162 LBS	EA	N/A	124206.5
7 TON	OVERHAUL BALL UB500	109.00 LBS	EA	7 TON	124235
10 TON	OVERHAUL BALL UB500	365.00 LBS	EA	10 TON	124236
12 TON	OVERHAUL BALL UB500	258.00 LBS	EA	12 TON	124238

NOTE: ADDITIONAL SIZES AVAILABLE



ALUMINUM BLOCK, SYNTHETIC ROPE

SIZE	DESCRIPTION	WEIGHT	UNIT	WORKING LOAD LIMIT	STOCK NO.
6"	W/HOOK 3/8"-5/8" ROPE	5.00 LBS	EA	1,250 LBS	119000

SNATCH BLOCK, MANILA ROPE



SIZE	DESCRIPTION	WEIGHT	UNIT	WORKING LOAD LIMIT	STOCK NO.
6"	STEEL W/HOOK VT390C	7.00 LBS	EA	2,400 LBS	113001
6"	STEEL W/EYE				113002
8"	PTD W/HOOK VT390C	13.00 LBS	EA	4,800 LBS	113003
8"	STEEL W/EYE				113004
10"	STEEL W/ HOOK VT390C	25.00 LBS	EA	6,600 LBS	113005

STEEL BLOCK, MANILA ROPE



SIZE	DESCRIPTION	WEIGHT	UNIT	WORKING LOAD LIMIT	STOCK NO.
3"	SINGLE W/HOOK & LATCH	0.75 LBS	EA	500 LBS	114801
4"	SINGLE W/HOOK & LATCH	1.38 LBS	EA	900 LBS	114802
5"	SINGLE W/HOOK & LATCH	2.35 LBS	EA	1,200 LBS	114803
6"	SINGLE W/HOOK & LATCH	3.75 LBS	EA	1,800 LBS	114804
10"	STEEL BLOCK, SWIVEL SHACKLE	48.00 LBS	EA	8,000 LBS	121622
12"	STEEL BLOCK, SINGLE, SWIVEL HOOK	52.00 LBS	EA	8,000 LBS	121605
3"	DOUBLE W/HOOK & LATCH	1.37 LBS	EA	800 LBS	114846
4"	DOUBLE W/HOOK & LATCH	2.50 LBS	EA	1,400 LBS	114847
5"	DOUBLE W/HOOK & LATCH	3.88 LBS	EA	1,800 LBS	114848
6"	DOUBLE W/HOOK & LATCH	6.00 LBS	EA	2,500 LBS	114849
8"	DOUBLE W/HOOK & LATCH	10.75 LBS	EA	3,800 LBS	114850
3"	TRIPLE W/HOOK & LATCH	1.63 LBS	EA	1,200 LBS	114891
8"	BLOCK TRIPLE W/HOOK & LATCH	7.13 LBS	EA	2,800 LBS	114911

WARNING

To prevent the possibility of serious bodily injury:
 • DO NOT EXCEED the working load limits

BLOCKS

MANILA ROPE BLOCK GALVANIZED WOODEN SHELL



SIZE	FITS ROPE SIZE	DESCRIPTION	WEIGHT	UNIT	WORKING LOAD LIMIT	STOCK NO.
3"	3/8"	MANILA, SW-HOOK, SINGLE	1.00 LBS	EA	500 LBS	117021
3"	3/8"	MANILA, SW-HOOK, DOUBLE	1.75 LBS	EA	800 LBS	117066
3"	3/8"	MANILA, HOOK, TRIPLE	3.13 LBS	EA	1,200 LBS	117091
4"	1/2"	MANILA, SW-HOOK, SINGLE	1.75 LBS	EA	1,000 LBS	117022
4"	1/2"	MANILA, HOOK, SINGLE	1.75 LBS	EA	1,000 LBS	117032
4"	1/2"	MANILA, SW-HOOK, DOUBLE	3.00 LBS	EA	1,400 LBS	117067
4"	1/2"	MANILA, HOOK, TRIPLE	5.25 LBS	EA	1,800 LBS	117096
5"	5/8"	MANILA, SW-HOOK, SINGLE	3.25 LBS	EA	1,200 LBS	117003
5"	5/8"	MANILA, SW-HOOK, DOUBLE	5.60 LBS	EA	1,800 LBS	117048
5"	5/8"	MANILA, HOOK, TRIPLE	6.19 LBS	EA	2,400 LBS	117093
6"	3/4"	MANILA, SW-HOOK, SINGLE	5.00 LBS	EA	1,800 LBS	117004
6"	3/4"	MANILA, SW-HOOK, DOUBLE	8.50 LBS	EA	2,500 LBS	117049
6"	3/4"	MANILA, HOOK, TRIPLE	13.22 lbs	EA	3,200 LBS	117094
8"	7/8-1"	MANILA, SW-HOOK, SINGLE	9.00 LBS	EA	2,800 LBS	117035
8"	7/8-1"	MANILA, SW-HOOK, DOUBLE	14.00 LBS	EA	3,800 LBS	117050
8"	7/8-1"	MANILA, HOOK, TRIPLE	21.50 LBS	EA	4,800LBS	117051
10"	1 1/8"	MANILA, SW-HOOK, SINGLE	15.97 LBS	EA	4,000 LBS	117203
10"	1/18"	MANIL, SW-HOOK, DOUBLE	23.98 LBS	EA	6,000 LBS	117219
10"	1 1/8"	MANILA, HOOK, TRIPLE	32.43 LBS	EA	8,000 LBS	117235

GIN WHEEL BLOCK

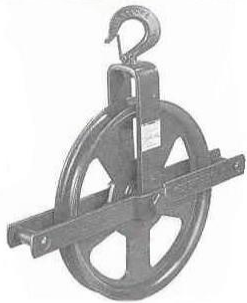

SIZE	DESCRIPTION	WEIGHT	UNIT	WORKING LOAD LIMIT	STOCK NO.
12"	GIN WHEEL BLOCK	14.0 LBS	EA	1000 LBS	112806
12"	REPLACEMENT WHEEL	7.62 LBS	EA	N/A	112806.1

HAY FORK PULLEY



SIZE	MODEL NO.	WEIGHT	UNIT	WIRE SIZE	WORKING LOAD LIMIT	STOCK NO.
4 1/2"	VM4	6.00 LBS	EA	1 1/2 MANILA	1 TON	117905
4 1/2"	VW4	6.00 LBS	EA	1/2" WIRE	1 TON	117906
6"	VW6	11.00 LBS	EA	5/8" WIRE	2 TON	117907

WARNING

To prevent the possibility of serious bodily injury:
 • DO NOT EXCEED the working load limits

BLOCKS

B&L STAR METAL BLOCK

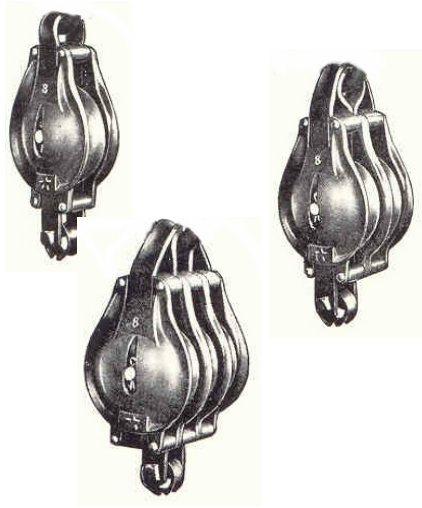

SIZE	NUMBER OF SHEAVES	WEIGHT	UNIT	WORKING LOAD LIMIT	STOCK NUMBER
4"	SINGLE	2.50 LBS	EA	1,100 LBS	114501
4"	DOUBLE	3.50 LBS	EA	1,600 LBS	114511
4"	TRIPLE	4.50 LBS	EA	2,200 LBS	114521
6"	SINGLE	6.00 LBS	EA	2,000 LBS	114502
6"	DOUBLE	9.50 LBS	EA	3,300 LBS	114512
6"	TRIPLE	12.00 LBS	EA	4,000 LBS	114522
8"	SINGLE	11.00 LBS	EA	3,300 LBS	114503
8"	DOUBLE	16.50 LBS	EA	5,100 LBS	114513
8"	TRIPLE	23.00 LBS	EA	7,000 LBS	114523
10"	SINGLE	23.00 LBS	EA	5,000 LBS	114504
10"	DOUBLE	34.00 LBS	EA	7,700 LBS	114514
10"	TRIPLE	42.00 LBS	EA	10,000 LBS	114524



TRY NET BLOCK

SIZE	WEIGHT	UNIT	WORKING LOAD LIMIT	STOCK NO.
6"	23.00 LBS	EA	5 TONS	123406
8"	36.00 LBS	EA	10 TONS	123407



TRAWL BLOCK

SIZE	WEIGHT	UNIT	WORKING LOAD LIMIT	STOCK NO.
12"	85.00 LBS	EA	10 TONS	123402
16"	116.00 LBS	EA	20 TONS	123403

WARNING

To prevent the possibility of serious bodily injury:
 • DO NOT EXCEED the working load limits

INSULATED LINKS

CONSTRUCTION

Glass filament reinforced. No adjoining metal parts. Non-conductive central core held between 2 metal alloy spoke ends. Resin-impregnated fiberglass strands wound between the spokes. No metal interlocks...no reduction of insulated capacity under load.

PROTECTION

Use ANYWHERE there is a hazard from electrical shock or burn. (up to 50 KV) Higher KV ratings available as specials. Protects: Construction Crews, hook Tenders, Riggers, Hoist-Supported Welders, Load Handling Workers and Boom Crane Personnel.

STRENGTH

Each link electrically tested at 2X rated capacity. Links rated 1/2 to 100 standard short tons are tested to 2X tonnage.



Insulated Links are available with choice of one of the following:

- Hook at the bottom, stud at top. Stud machined to fit hoist load block.
- Hook at bottom, bail at top - for use with existing hook.
- Bail at both ends - for use as inline insulating swivel unit.
- Threaded stud at both ends for use as solid dielectric connector.

What is RF?

Radio-Frequency (RF) is continuous electrical discharge emitting from radar, radio and television towers, microwave transmitters, satellites and other high frequency wireless communicators. These high frequency radio waves travel through the atmosphere and will increase as wireless communication expands.

RF is Hazardous.

RF waves are picked up by all antennas or metal objects and will cause continual electrical discharge unless properly insulated. Cranes and other loading devices will pick up RF waves which can burn load handlers. In extreme cases, RF can produce dangerous high voltage electrical arcing.

Protect against RF

Hirtzer Insulators placed between the hook and lifting device will stop RF from discharging to the end of the hook. Protects the load handler from electrical burns.

It also protects sensitive electronics from damage.

INSULATED LINKS

ROUND LINK

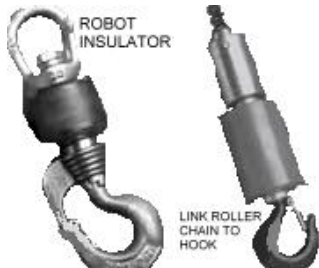

Short Tons	KV Value	Overall Link Length	Length from top of link to Hook Basket	Overall Length from bearing point of bail to hook basket	Diameter of Link Body	Thread Size in Stud End	Recommended Stud Diameter
1/2	1 KV	4 1/2"	7"	9 3/4"	2 5/8"	5/8-UNC	5/8"
1/2	10 KV	5 1/4"	7 3/4"	10 1/2"	2 5/8"	5/8-UNC	5/8"
1	1 KV	4 1/2"	7 1/2"	10 3/4"	2 5/8"	3/4-8UNC	3/4"
1	10KV	5 1/4"	8 1/4"	11 3/4"	2 5/8"	3/4-8UNC	3/4"
2	1 KV	6 1/2"	10 1/4"	14 1/2"	4 1/4"	1 1/8-7UNC	1 1/8"
2	10 KV	7 1/2"	11 1/4"	15 1/2"	4 1/4"	1 1/8-7UNC	1 1/8"
2	50 KV	15 1/2"	19 1/4"	23 1/2"	4 1/4"	1 1/8-7UNC	1 1/8"
3	1 KV	6 1/2"	10 1/4"	13 3/4"	4 1/4"	1 1/4-7UNC	1 1/4"
3	10KV	7 1/2"	11 1/4"	14 3/4"	4 1/4"	1 1/4-7UNC	1 1/4"
3	50 KV	15 1/2"	19 1/4"	22 3/4"	4 1/4"	1 1/4-7UNC	1 1/4"
5	1 KV	8 1/4"	13"	18"	6"	1 3/8-6UNC	1 3/8"
5	10 KV	9 1/4"	14"	19"	6"	1 3/8-6UNC	1 3/8"
5	50 KV	17"	21 3/4"	26 3/4"	6"	1 3/8-6UNC	1 3/8"
10	1 KV	8 1/4"	14 3/4"	20"	6"	2-4 1/2 TPI	2"
10	10 KV	9 1/4"	15 3/4"	21"	6"	2-4 1/2 TPI	2"
10	50 KV	17"	23 1/2"	28 3/4"	6"	2-4 1/2 TPI	2"
15	1 KV	9 1/4"	17 1/4"	25 1/4"	7 3/4"	2 1/4-8 TPI	2 1/4"
15	10 KV	10 1/4"	18 1/4"	26 1/4"	7 3/4"	2 1/4-8 TPI	2 1/4"
15	50 KV	18 1/4"	26 1/4"	34 1/4"	7 3/4"	2 1/4-8 TPI	2 1/4"
20	1 KV	9 1/4"	17 1/4"	25"	7 3/4"	2 1/2-8 TPI	2 1/2"
20	10 KV	10 1/4"	18 1/4"	26"	7 3/4"	2 1/2-8 TPI	2 1/2"
20	50 KV	18 1/4"	26 1/4"	34"	7 3/4"	2 1/2-8 TPI	2 1/2"
25	1 KV	9 1/4"	18 3/4"		7 3/4"	2 3/4-8 TPI	2 3/4"
25	10 KV	10 1/4"	19 3/4"		7 3/4"	2 3/4-8 TPI	2 3/4"
25	50 KV	18 1/4"	27 3/4"		7 3/4"	2 3/4-8 TPI	2 3/4"
40	50 KV	19 1/4"	33 1/4"		10"	4-8 TPI	4"
50	50 KV	19 1/4"	34 3/4"		10"	4-8 TPI	4"
60	50 KV	19"	34 1/2"		13"	4-8 TPI	4"
80	50 KV	20 1/2"	39"		16 1/2"	4 or 6-8 TPI	4 or 6"
100	50 KV	28"	46 1/2"		16 1/2"	6-8 TPI	6"
120	50 KV	28"	46 1/2"		19 5/8"	6-8 TPI	6"

INLINE LINK



Short Tons	Overall Link Length	Width	Thickness	Pin Hole Size
1/2 TON	3 5/8"	1.0"	1/2"	1/2"
1 TON	3 5/8"	1 3/8"	1/2"	1/2"
3 TON	5 5/8"	2 1/2"	15/16"	13/16"
5 TON	7"	3.0"	1 1/16"	1 1/16"
10 TON	11 3/8"	4.0"	1 13/16"	1 7/16"
20 TON	15 3/4"	6.0"	2 3/4"	2 1/16"
40 TON	22 3/4"	8.0"	4.0"	2 13/16"
60 TON	28 5/8"	10.0"	4 7/8"	3 5/16"

WARNING

To prevent the possibility of serious bodily injury:
 • DO NOT EXCEED the working load limits

SWIVELS

SWIVEL



SIZE	TYPE	WEIGHT	UNIT	WORKING LOAD LIMIT	STOCK NO.
2 TON	EYE & EYE	5.00 LBS	EA	2 TON	806000
2 TON	JAW & HOOK	9.80 LBS	EA	2 TON	804000
2 TON	JAW & JAW	9.63 LBS	EA	2 TON	804500
3 TON	EYE & EYE	8.50 LBS	EA	3 TON	806001
3 TON	EYE & HOOK	9.32 LBS	EA	3 TON	806501
3 TON	EYE & JAW	9.00 LBS	EA	3 TON	805501
3 TON	JAW & HOOK	9.50 LBS	EA	3 TON	804001
3 TON	JAW & JAW	9.81 LBS	EA	3 TON	804501
5 TON	EYE & EYE	11.30 LBS	EA	5 TON	806010
5 TON	EYE & HOOK	14.25 LBS	EA	5 TON	806510
5 TON	EYE & JAW	12.33 LBS	EA	5 TON	805510
5 TON	JAW & HOOK	15.51 LBS	EA	5 TON	804010
5 TON	JAW & JAW	13.69 LBS	EA	5 TON	804510
5 TON	JAW & SOCKET	14.00 LBS	EA	5 TON	805610
8.5 TON	EYE & EYE	29.25 LBS	EA	8.5 TON	806013.1
8.5 TON	EYE & JAW	29.00 LBS	EA	8.5 TON	805513.1
8.5 TON	JAW & HOOK	29.45 LBS	EA	8.5 TON	804013
8.5 TON	JAW & JAW	26.20 LBS	EA	8.5 TON	804513.1
10 TON	EYE & EYE	42.00 LBS	EA	10 TON	806014
10 TON	EYE & HOOK	45.50 LBS	EA	10 TON	806514
10 TON	EYE & JAW	44.00 LBS	EA	10 TON	805514
10 TON	JAW & JAW	45.75 LBS	EA	10 TON	804514
12 TON	EYE & EYE	46.00 LBS	EA	12 TON	806016
15 TON	JAW & JAW	62.75 LBS	EA	15 TON	804517

BULLET STYLE ANGULAR SWIVEL



SIZE	TYPE	WEIGHT	UNIT	WORKING LOAD LIMIT	STOCK NO.
0.45 TON	JAW & JAW	0.50 LBS	EA	.45 TON	807501
3/4 TON	JAW & JAW	1.00 LBS	EA	3/4 TON	817002
1.5 TON	JAW & JAW	2.00 LBS	EA	1.5 TON	807563
1.5 TON	EYE & EYE	2.00 LBS	EA	1.5 TON	807580
3 TON	JAW & JAW	4.00 LBS	EA	3 TON	807567
3 TON	EYE & EYE	4.00 LBS	EA	3 TON	807581
5 TON	JAW & JAW	8.00 LBS	EA	5 TON	807569

WARNING

To prevent the possibility of serious bodily injury:
 • **DO NOT EXCEED** the working load limits

SWIVELS

REGULAR SWIVEL



SIZE	TYPE	WEIGHT	UNIT	WORKING LOAD LIMIT	STOCK NO.
1/4"	JAW END	0.21 LBS	EA	850 LBS	802008
1/4"	EYE & EYE	0.21 LBS	EA	850 LBS	801508
5/16"	JAW END	0.34 LBS	EA	1,250 LBS	802010
5/16"	EYE & EYE	0.39 LBS	EA	1,250 LBS	801510
3/8"	JAW END	0.66 LBS	EA	2,250 LBS	802012
3/8"	EYE & EYE	0.71 LBS	EA	2,250 LBS	801512
1/2"	JAW END	1.34 LBS	EA	3,600 LBS	802016
1/2"	EYE & EYE	1.32 LBS	EA	3,600 LBS	801516
5/8"	JAW END	2.48 LBS	EA	5,200 LBS	802020
5/8"	EYE & EYE	2.49 LBS	EA	5,200 LBS	801520
3/4"	JAW END	3.88 LBS	EA	7,200 LBS	802024
3/4"	EYE & EYE	4.02 LBS	EA	7,200 LBS	801524
7/8"	EYE & EYE	6.25 LBS	EA	10,000 LBS	801528
1"	JAW END	9.84 LBS	EA	12,500 LBS	802032
1 1/4"	EYE & EYE	16.37 LBS	EA	18,000 LBS	801540
1 1/4"	JAW END	15.75 LBS	EA	18,000 LBS	802040
1 1/2"	EYE & EYE	45.79 LBS	EA	45,200 LBS	801548
1 1/2"	JAW END	54.375 LBS	EA	45,200 LBS	802048

CHAIN SWIVEL



SIZE	WEIGHT	UNIT	WORKING LOAD LIMIT	STOCK NO.
1/4"	0.13 LBS	EA	850 LBS	801008
5/16"	0.25 LBS	EA	1,250 LBS	801010

⚠ WARNING

To prevent the possibility of serious bodily injury:
 • **DO NOT EXCEED** the working load limits

WEDGE SOCKET

WEDGE SOCKET, COMPLETE



SIZE	WEIGHT	UNIT	STOCK NO.
3/8"	4.60 LBS	EA	708512
1/2"	8.50 LBS	EA	708516
5/8"	8.50 LBS	EA	708520
3/4"	9.00 LBS	EA	708524
7/8"	15.00 LBS	EA	708528
1"	20.80 LBS	EA	708532
1 1/8"	46.50 LBS	EA	708536
1 1/4"	57.00 LBS	EA	708540

WEDGE ONLY FOR SOCKET



SIZE	WEIGHT	UNIT	STOCK NO.
3/8"	0.60 LBS	EA	709012
7/16"	0.60 LBS	EA	709014
1/2"	1.00 LBS	EA	709016
9/16"	1.00 LBS	EA	709018
5/8"	1.40 LBS	EA	709020
3/4"	1.40 LBS	EA	709024
7/8"	2.60 LBS	EA	709028
1"	3.00 LBS	EA	709032
1-1/8"	3.00 LBS	EA	709036
1 1/4"	7.00 LBS	EA	709040

WEDGE SOCKET, COMPLETE (GUNNEBO JOHNSON)



SIZE	PART NO.	WEIGHT	UNIT	STOCK NO.
3/8"	WS4	3.00 LBS	EA	709712
7/16"	WS4	3.00 LBS	EA	709714
1/2" & 5/8"	WS4	3.00 LBS	EA	709716
1/2"	WS5	8.50 LBS	EA	709717
9/16"	WS5	8.50 LBS	EA	709718
1/2" & 5/8"	WS-5	8.50 LBS	EA	709720
5/8" & 3/4"	WS-6	9.00 LBS	EA	709721
5/8"	WS8A	17.00 LBS	EA	709722
3/4"	WS-6	9.00 LBS	EA	709724
3/4"	WS8A	17.00 LBS	EA	709725
7/8" & 1"	WS-7	15.00 LBS	EA	709728
7/8" & 1"	WS-8	16.00 LBS	EA	709729
1"	WS-7	14.50 LBS	EA	709732
1"	WS-8	16.00 LBS	EA	709733
1 1/8"	WS-10	45.00 LBS	EA	709736
1 1/8"	WS11	55.00 LBS	EA	709737
1 1/4"	WS-10	45.00 LBS	EA	709740
1 1/4"	WS-11	55.00 LBS	EA	709741

WARNING

To prevent the possibility of serious bodily injury:
 • DO NOT EXCEED the working load limits

WEDGE SOCKET

WEDGE ONLY (FOR GUNNEBO JOHNSON)



SIZE	PART NO.	WEIGHT	UNIT	STOCK NO.	SIZE	PART NO.	WEIGHT	UNIT	STOCK NO.
3/8"	WS-4	0.60 LBS	EA	709812	7/8"	WS-7	2.00 LBS	EA	709828
7/16"	WS-4	0.60 LBS	EA	709814	7/8"	WS-8	3.00 LBS	EA	709829
1/2"	WS-4	0.60 LBS	EA	709816	7/8"	WS-7 & 8	3.25 LBS	EA	709830
1/2"	WS-5	1.00 LBS	EA	709817	1"	WS-7	2.60 LBS	EA	709832
9/16"	WS-5	1.00 LBS	EA	709818	1"	WS-8	3.10 LBS	EA	709833
5/8"	WS-5	1.00 LBS	EA	709820	1 1/8"	WS-10	9.00 LBS	EA	709836
5/8"	WS-6	1.40 LBS	EA	709821	1 1/8"	WS-11	7.00 LBS	EA	709837
5/8"	WS-8A	3.00 LBS	EA	709822	1 1/4"	WS-10	9.00 LBS	EA	709840
3/4"	WS-6	1.40 LBS	EA	709824	1 1/4"	WS-11	7.00 LBS	EA	709841
3/4"	WS-8A	3.00 LBS	EA	709825					

WEDGE SOCKET COMPLETE, TERMINATOR (CROSBY 421T)



SIZE	WEIGHT	UNIT	STOCK NO.
1/2"	5.75 LBS	EA	709116
5/8"	8.27 LBS	EA	709120
3/4"	13.80 LBS	EA	709124
7/8"	20.50 LBS	EA	709128
1"	29.60 LBS	EA	709132
1 1/8"	42.88 LBS	EA	709136

WEDGE ONLY (FOR TERMINATOR 421T ABOVE)



SIZE	WEIGHT	UNIT	STOCK NO.
3/8"	0.60 LBS	EA	709212
1/2"	1.00 LBS	EA	709216
5/8"	1.40 LBS	EA	709220
3/4"	2.60 LBS	EA	709224
7/8"	4.02 LBS	EA	709228
1"	5.37 LBS	EA	709232
1 1/8"	7.84 LBS	EA	709236

⚠ WARNING

To prevent the possibility of serious bodily injury:
 * DO NOT EXCEED the working load limits

SHEAVES

USE THIS FORM TO SPECIAL ORDER SHEAVES

A	
OUTSIDE DIAMETER	
B	
ROPE DIAMETER	
C	
BORE	
D	
RIM WIDTH	
E	
HUB WIDTH	
F	
HUB DIAMETER	
G	
BRONZE, BUSHING, BEARING OR FINISHED BORE	
H	
QUANTITY	

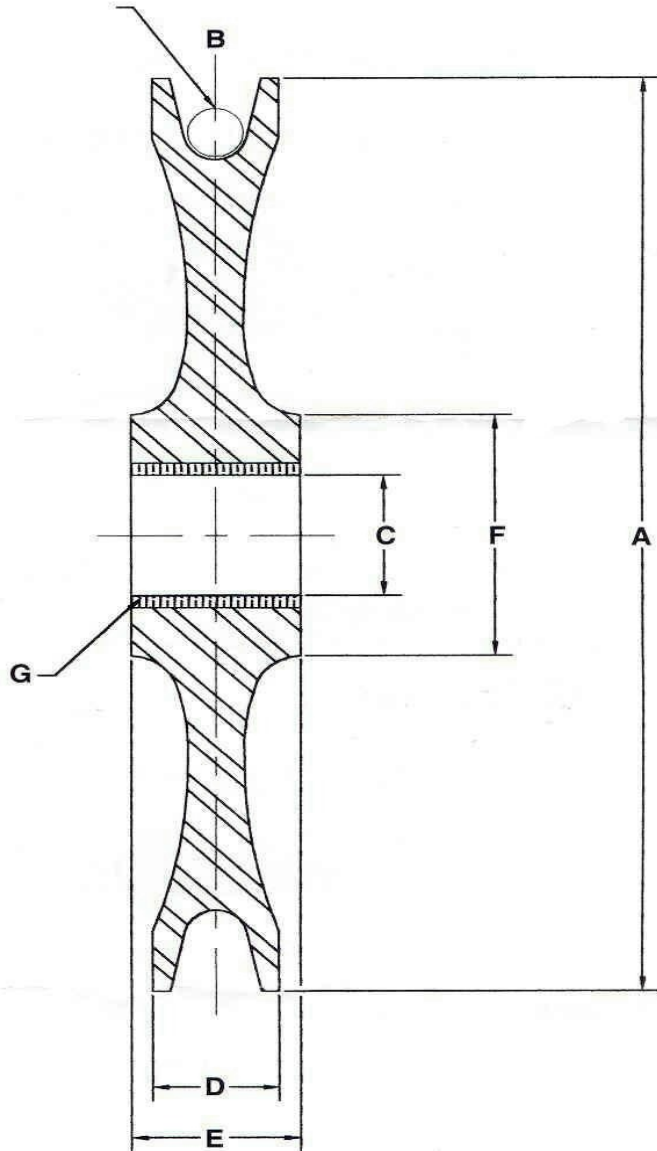

COMPANY	VOLUNTEER WIRE ROPE & SUPPLY CO. 2706 John Deere Drive KNOXVILLE, TN 37917 TOLL FREE PHONE FAX 800-333-5789 (865)546-8613 (865)522-6619 www.volwire.com
CONTACT:	
PHONE #	
FAX #	

SHEAVES

1" TO 4" DIAMETER



DIAMETER	SHAFT	WIRE ROPE	DESCRIPTION	WEIGHT	UNIT	STOCK NO.
1 1/2"	1/2"	3/16"	BRONZE BUSHING	0.20 LBS	EA	600515I
2"	1/2"	1/4"	BRONZE BUSHING	0.30 LBS	EA	600520I
2 1/2"	1/2"	1/4"	BRONZE BUSHING	0.50 LBS	EA	600525I
3"	1/2"	5/16"	BRONZE BUSHING	0.80 LBS	EA	600530I
3"	9/16"	3/8"	BRONZE BUSHING	0.80 LBS	EA	600536I
3 1/2"	3/4"	3/8"	BRONZE BUSHING	1.30 LBS	EA	600535I
4"	3/4"	1/2"	BRONZE BUSHING	2.00 LBS	EA	600540
4"	1"	3/8"	BRONZE BUSHING	2.50 LBS	EA	600545
4"	5/8"	3/8"	BRONZE BUSHING	1.50 LBS	EA	601415
4"	3/4"	1/2"	BRONZE BUSHING	1.50 LBS	EA	601419

5" TO 7" DIAMETER



DIAMETER	SHAFT	WIRE ROPE	DESCRIPTION	WEIGHT	UNIT	STOCK NO.
5"	3/4"	1/2"	BRONZE BUSHING	3.56 LBS	EA	600550
5"	3/4"	3/16"	BRONZE BUSHING	2.50 LBS	EA	601422
5"	3/4"	7/16"	BRONZE BUSHING	2.50 LBS	EA	602521
5 1/4"	1"	5/8"	BRONZE BUSHING	4.00 LBS	EA	602525
6"	3/4"	1/2"	BRONZE BUSHING	5.63 LBS	EA	600560
6"	1 1/4"	1/2"	PLAIN BORE	6.00 LBS	EA	600562
6"	1"	1/2"	BRONZE BUSHING	5.63 LBS	EA	600568
6"	3/4"	1/2"	BRONZE BUSHING	6.00 LBS	EA	601501
6"	3/4"	3/8"	BRONZE BUSHING	2.50 LBS	EA	601431
6"	3/4"	1/2"	BRONZE BUSHING	3.70 LBS	EA	601436
6"	1"	1/2"	BRONZE BUSHING	4.00 LBS	EA	601819
6"	1"	5/8"	BRONZE BUSHING	4.00 LBS	EA	601817
6"	1 3/4"	3/4"	BRONZE BUSHING	6.60 LBS	EA	602536
7"	7/8"	1/2"	BRONZE BUSHING	4.25 LBS	EA	601438
7"	3/4"	1/2"	BRONZE BUSHING	4.25 LBS	EA	601437

WARNING

To prevent the possibility of serious bodily injury:
 • **DO NOT EXCEED** the working load limits

SHEAVES

8" TO 12" DIAMETER



DIAMETER	SHAFT	WIRE ROPE	DESCRIPTION	WEIGHT	UNIT	STOCK NO.
8"	3/4"	1/2"	PLAIN BORE	5.00 LBS	EA	601045
8"	1 1/4"	1/2"	BRONZE BUSHING	7.00 LBS	EA	601847
8"	1 1/2"	5/8"	BRONZE BUSHING	10.00 LBS	EA	602550
8"	3/4"	1/2"	BRONZE BUSHING	5.00 LBS	EA	601445
8"	1"	5/8"	BRONZE BUSHING	7.20 LBS	EA	601517
8"	1 1/2"	5/8"	BRONZE BUSHING	8.50 LBS	EA	601520
8"	7/8"	5/8"	BRONZE BUSHING	8.50 LBS	EA	601842
8"	1 1/4"	1/2"	BRONZE BUSHING	7.00 LBS	EA	601847
10"	1 1/4"	3/4"	BRONZE BUSHING	16.00 LBS	EA	601543
10"	1"	1/2"	BRONZE BUSHING	11.80 LBS	EA	601458
10"	1 1/2"	5/8"	BRONZE BUSHING	12.60 LBS	EA	601539
10"	1 1/2"	7/8"	BRONZE BUSHING	20.00 LBS	EA	601852
10"	1 1/4"	5/8"	BRONZE BUSHING	14.00 LBS	EA	601865
10"	2 1/4"	1/2"	BRONZE BUSHING	25.00 LBS	EA	602588
12"	1 1/2"	3/4"	BRONZE BUSHING	25.00 LBS	EA	601554
12"	3"	1/2"	BRONZE BUSHING	18.00 LBS	EA	602603
12"	2"	3/4"	BRONZE BUSHING	26.00 LBS	EA	602607
12"	2 1/2"	5/8"	BRONZE BUSHING	24.00 LBS	EA	602616
12"	1 1/4"	3/4"	BRONZE BUSHING	25.50 LBS	EA	601553

13" TO 24" DIAMETER



DIAMETER	SHAFT	WIRE ROPE	DESCRIPTION	WEIGHT	UNIT	STOCK NO.
13"	1 5/16"	1/2"	PLAIN BORE	27.00 LBS	EA	602699
16"	1 1/4"	1"	BRONZE BUSHING	25.00 LBS	EA	602688
18"	2 1/2"	7/8"	BRONZE BUSHING	5.00 LBS	EA	602724.1
20"	4"	1 1/8"	BRONZE BUSHING	75.25 LBS	EA	602761.1
20"	2"	3/4"	PLAIN BORE	45.00 LBS	EA	602165
24"	4"	1"	BRONZE BUSHING	80.00 LBS	EA	602168

⚠ WARNING

To prevent the possibility of serious bodily injury:
 • DO NOT EXCEED the working load limits

PLATE CLAMPS

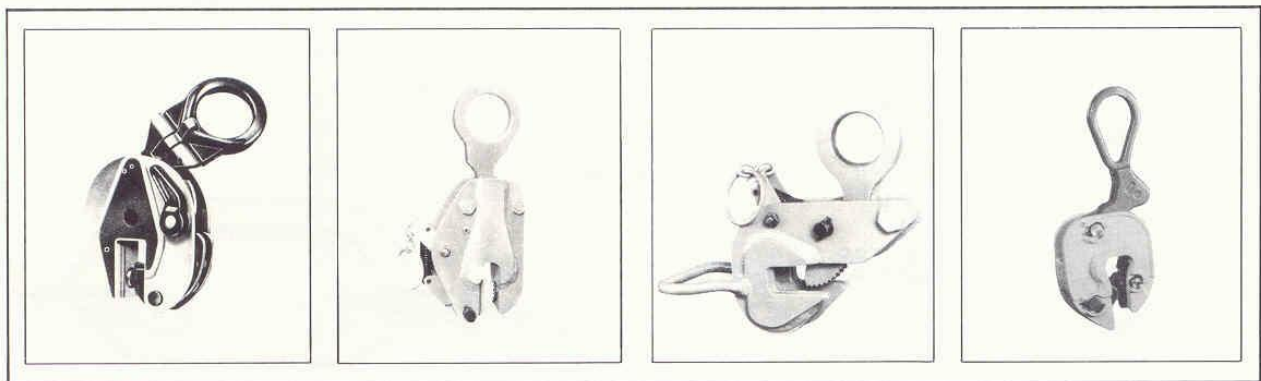
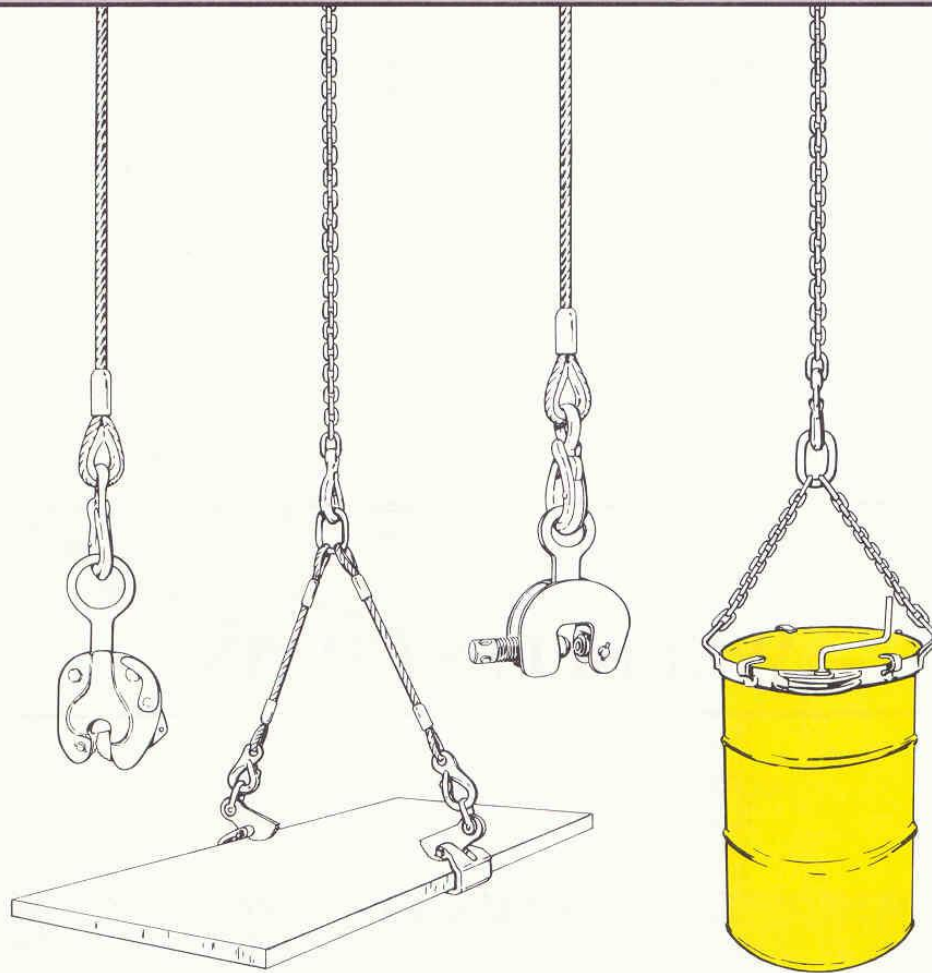

**DON'T SEE WHAT YOU NEED?
ASK YOUR SALES REPRESENTATIVE.**

PLATE CLAMPS

WARNINGS

1. **DO** consult Operator's manual or RENFROE when in doubt. RENFROE factory representatives are available upon request at no charge to train and assist in establishing the proper use of RENFROE products.
2. **DO** lock clamp closed before lifting load. **NEVER** lift with Lock in open or "Lock Open" position.
3. **DO** use safety hooks. **NEVER** use a hook that may release clamp.
4. **DO** use an adequate number of clamps to balance load. **NEVER** lift loads that are not balanced.
5. **DO** use clamps within their rated capacity. **NEVER** overload clamp.
6. **DO** inspect clamp before each lift, follow inspection and maintenance instructions and use RENFROE replacement parts to assure proper operation of the clamp.
7. **DON'T** side load. **NEVER** lift from side with vertical clamp.
8. **DON'T** lift over workmen. **NEVER** lift over Safety Areas or personnel.
9. **DON'T** misuse. **NEVER** lift plate from bottom of plate stack.
10. **DON'T** rush. **NEVER** lift more than one plate at a time with a vertical clamp.
11. **DON'T** improvise. Always use correct clamp for job. **NEVER** lift horizontally with a vertical clamp.
12. **DON'T** use clamp that has been overloaded.
13. **DON'T** alter clamp. **NEVER** grind, weld or modify the clamp in any manner.

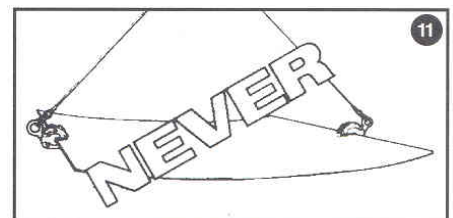
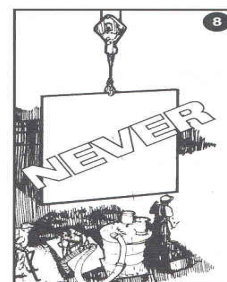
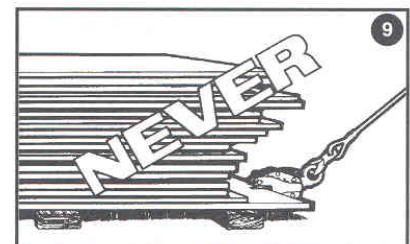
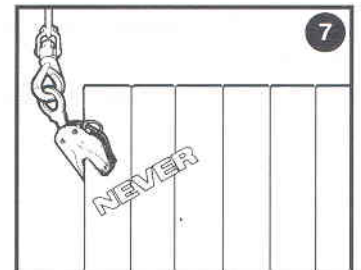
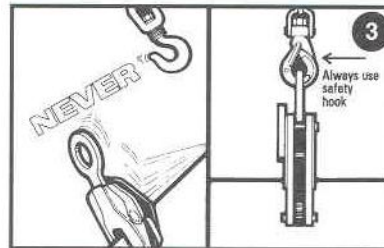
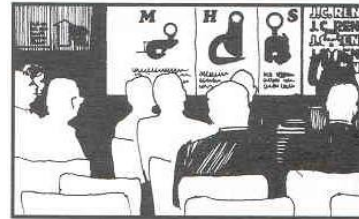

PLATE CLAMPS



VERTICAL LIFTING, LOCKING RENFROE® MODEL FR

SIZE	PLATE THICKNESS	WEIGHT	UNIT	WORKING LOAD LIMIT	STOCK NO.
1/2 TON	0-3/4"	8.00 LBS	EA	1/2 TON	447701
1 TON	0-3/4"	14.00 LBS	EA	1 TON	447706
2 TON	0-1"	23.00 LBS	EA	2 TON	447712
3 TON	0-1 1/4"	30.00 LBS	EA	3 TON	447716



VERTICAL LIFTING, LOCKING RENFROE® MODEL S

SIZE	PLATE THICKNESS	WEIGHT	UNIT	WORKING LOAD LIMIT	STOCK NO.
8 TON	0-1 1/2"	70.00 LBS	EA	8 TON	448911



VERTICAL LIFTING, LOCKING RENFROE® MODEL SX

SIZE	PLATE THICKNESS	WEIGHT	UNIT	WORKING LOAD LIMIT	STOCK NO.
2 TON	0-1"	34.00 LBS	EA	2 TON	449301



VERTICAL LIFTING, NON-LOCKING RENFROE® MODEL BD

SIZE	PLATE THICKNESS	WEIGHT	UNIT	WORKING LOAD LIMIT	STOCK NO.
1/2 TON	0-1"	6.00 LBS	EA	1/2 TON	447501
1 TON	0-1 1/8"	11.00 LBS	EA	1 TON	447502
2 TON	0-1 3/8"	16.00 LBS	EA	2 TON	447503

WARNING

To prevent the possibility of serious bodily injury:
 • DO NOT EXCEED the working load limits

PLATE CLAMPS

LOCKING RENFROE® MODEL M



SIZE	PLATE THICKNESS	WEIGHT	UNIT	WORKING LOAD LIMIT	STOCK NO.
1/2 TON	0-1"	7.00 LBS	EA	1/2 TON	448301
1 TON	0-1"	11.00 LBS	EA	1 TON	448304
2 TON	0-1 1/4"	23.00 LBS	EA	2 TON	448307
4 TON	0-1 1/2"	36.00 LBS	EA	4 TON	448310

NON-LOCKING RENFROE® MODEL AST/ASTL



SIZE	MODEL	PLATE THICKNESS	WEIGHT	UNIT	WORKING LOAD LIMIT	STOCK NO.
1/2 TON	AST	0-3/4"	10.00 LBS	EA	1/2 TON	447101
1 1/2 TON	AST	0-3/4"	24.00 LBS	EA	1 1/2 TON	447102
3 TON	AST	0-1 1/2"	50.00 LBS	EA	3 TON	447103
1 1/2 TON	ASTL	0-3/4"	24.00 LBS	EA	1 1/2 TON	447202
3 TON	ASTL	0-1 1/2"	61.00 LBS	EA	3 TON	447203

LOCKING, SCREW TYPE RENFROE® MODEL SCP



SIZE	PLATE THICKNESS	WEIGHT	UNIT	WORKING LOAD LIMIT	STOCK NO.
1/2 TON	0-3/4"	8.00 LBS	EA	1/2 TON	449001
1 1/2 TON	0-1 1/4"	15.00 LBS	EA	1 1/2 TON	449002
3 TON	0-2"	24.00 LBS	EA	3 TON	449008

WARNING

To prevent the possibility of serious bodily injury:
 • **DO NOT EXCEED** the working load limits

PLATE CLAMPS

RENFROE® **PLATE CLAMP REPAIR KIT**



SIZE	FITS MODEL	WEIGHT	UNIT	WORKING LOAD LIMIT	STOCK NO.
1/2 TON	AST	1.25 LBS	EA	1/2 TON	44970101
1 1/2 TON	AST	2.75 LBS	EA	1 1/2 TON	44970102
3 TON	AST	7.94 LBS	EA	3 TON	44970103
1/2 TON	ASTL	1.50 LBS	EA	1/2 TON	44970801
1 1/2 TON	ASTL	3.08 LBS	EA	1 1/2 TON	44970802
3 TON	ASTL	7.95 LBS	EA	3 TON	44970803
1/2 TON	BD	1.75 LBS	EA	1/2 TON	44972101
1 TON	BD	3.27 LBS	EA	1 TON	44972102
1/2 TON	FR	2.00 LBS	EA	1/2 TON	44974101
1 TON	FR	2.50 LBS	EA	1 TON	44974102
2 TON	FR	4.25 LBS	EA	2 TON	44974103
3 TON	FR	6.19 LBS	EA	3 TON	44974104
1/2 TON	M	1.00 LBS	EA	1/2 TON	44983601
1 TON	M	1.30 LBS	EA	1 TON	44983602
2 TON	M	1.00 LBS	EA	2 TON	44983603
4 TON	M	4.75 LBS	EA	4 TON	44983604
1/2 TON	TL	8.30 LBS	EA	1/2 TON	44995601
1 TON	TL	8.60 LBS	EA	1 TON	44995602
2 TON	TL	8.56 LBS	EA	2 TON	44995603

SAFELINE CLAMP



SIZE	WEIGHT	UNIT	STOCK NO.
3/16"	0.25 LBS	EA	189006
1/4"	0.25 LBS	EA	189008
5/16"	0.50 LBS	EA	189010
3/8"	0.75 LBS	EA	189012
7/16"	1.25 LBS	EA	189014
1/2"	1.75 LBS	EA	189016
3/4"	2.25 LBS	EA	189024

WARNING

To prevent the possibility of serious bodily injury:
 * **DO NOT EXCEED** the working load limits

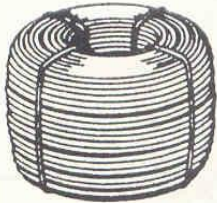
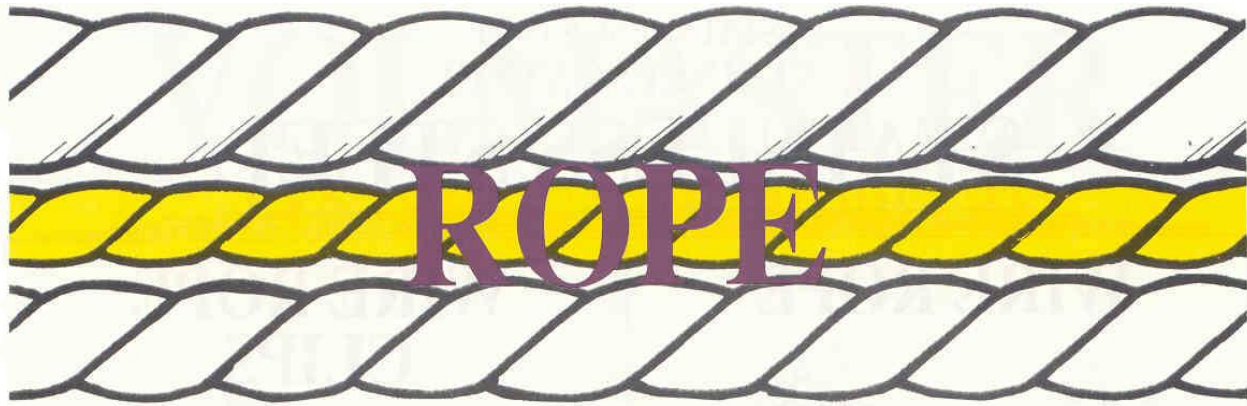

COIL

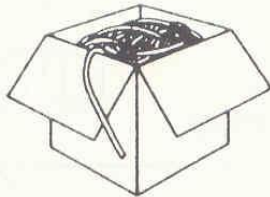

BULK CARTON

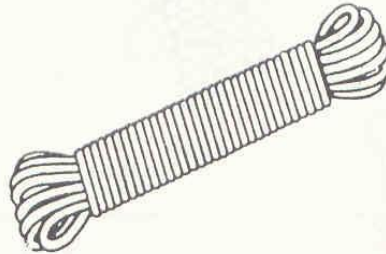

HANK

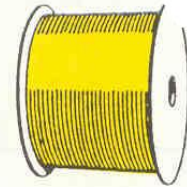

SPOOLS

SIZE DIAMETER	MANILA			NYLON			POLYPROPYLENE		
	NEW ROPE TENSILE STRENGTH (LBS.)	SAFETY FACTOR	WORKING LOAD (LBS.)	NEW ROPE TENSILE STRENGTH (LBS.)	SAFETY FACTOR	WORKING LOAD (LBS.)	NEW ROPE TENSILE STRENGTH (LBS.)	SAFETY FACTOR	WORKING LOAD (LBS.)
3/16	406	10	41	900	12	75	720	10	72
1/4	540	10	54	1,490	12	124	1,130	10	113
5/16	900	10	90	2,300	12	192	1,710	10	171
3/8	1,220	10	122	3,340	12	278	2,440	10	244
7/16	1,580	9	176	4,500	11	410	3,160	9	352
1/2	2,380	9	264	5,750	11	525	3,780	9	420
9/16	3,100	8	388	7,200	10	720	4,600	8	575
5/8	3,960	8	496	9,350	10	935	5,600	8	700
3/4	4,860	7	695	12,800	9	1,420	7,650	7	1,090
13/16	5,850	7	835	15,300	9	1,700	8,900	7	1,270
7/8	6,950	7	995	18,000	9	2,000	10,400	7	1,490
1	8,100	7	1,160	22,600	9	2,520	12,600	7	1,800
1 1/16	9,450	7	1,350	26,000	9	2,880	14,400	7	2,060
1 1/8	10,800	7	1,540	29,800	9	3,320	16,500	7	2,360
1 1/4	12,200	7	1,740	33,800	9	3,760	18,900	7	2,700
1 3/8	13,500	7	1,930	38,800	9	4,320	21,200	7	3,020
1 1/2	16,700	7	2,380	47,800	9	5,320	26,800	7	3,820
1 5/8	20,200	7	2,880	58,500	9	6,500	32,400	7	4,620
1 3/4	23,800	7	3,400	70,000	9	7,800	38,800	7	5,550
2	28,000	7	4,000	83,000	9	9,200	46,800	7	6,700

NEW ROPE TENSILE STRENGTHS: New rope tensile strengths are based on tests of new and unused rope of standard construction in accordance with Cordage Institute Standard Test Methods.

CAUTION—USE OF WORKING LOADS: Because of the wide range of rope use, rope conditions, exposure to the several factors affecting rope behavior, and the degree of risk to life and property involved, it is impossible to make blanket recommendations as to working loads. **IN ALL CASES WHERE ANY SUCH RISKS ARE PRESENT, OR THERE IS ANY QUESTION ABOUT THE LOADS INVOLVED OR THE CONDITIONS OF USE, THE WORKING LOAD SHOULD BE SUBSTANTIALLY REDUCED AND THE ROPE PROPERLY INSPECTED.**

ROPE

3 STRAND TWISTED COTTON, WHITE



SIZE	WEIGHT	UNIT	PKG QTY	RWL*		STOCK NO.
				5:1	12:1	
5/16"	0.20 LBS/FT	FT	600/1200'	900 LBS		501010
1/2"	0.06 LBS/FT	FT	600'	291/121 LBS		501016

*** RECOMMENDED WORKING LOAD LIMIT**

DOUBLE BRAID POLYESTER (BRAID ON BRAID)



SIZE	WEIGHT	UNIT	PKG QTY	RWL*		STOCK NO.
				5:1	12:1	
3/8"	0.04 LBS/FT	FT	600/1200'	1,017/424 LBS		505312
7/16"	0.06 LBS/FT	FT	600/1200'	1,380/575 LBS		505314
1/2"	0.08 LBS/FT	FT	600/1200'	1,782/743 LBS		505316
5/8"	0.125 LBS/FT	FT	600/1200'	2,700/1,125 LBS		505320
3/4"	0.179 LBS/FT	FT	600/1200'	3,780/1,575 LBS		505324
1"	0.31 LBS/FT	FT	600/1200'	6,696/2,790 LBS		505332
1 1/8"	0.44 LBS/FT	FT	600/1200'	8,352/3,480 LBS		505336
1 1/4"	0.49 LBS/FT	FT	600/1200'	9,720/4,050 LBS		505340

*** RECOMMENDED WORKING LOAD LIMIT**

HOLLOW BRAID POLYPROPYLENE

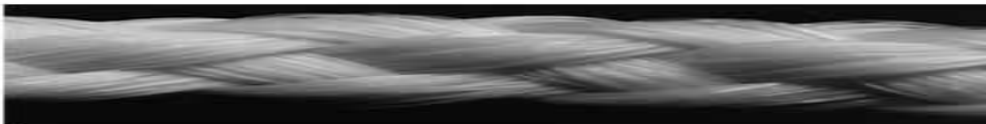

SIZE	WEIGHT	UNIT	PKG QTY	RWL*		STOCK NO.
				5:1	12:1	
1/8"	0.002 LBS/FT	FT	1000'	45/19 LBS		505504
3/16"	0.004 LBS/FT	FT	1000'	82 LBS		505506
1/4"	0.01 LBS/FT	FT	1000'	162/68 LBS		505508
5/16"	0.017 LBS/FT	FT	1000'	230/96 LBS		505510
3/8"	0.024 LBS/FT	FT	1000'	275/144 LBS		505512
1/2"	0.032 LBS/FT	FT	1000'	491/204 LBS		505516

*** RECOMMENDED WORKING LOAD LIMIT**

WARNING

To prevent the possibility of serious bodily injury:
* DO NOT EXCEED the working load limits

ROPE

MANILA NATURAL TAN COLOR, 3 STRAND TWISTED



SIZE	WEIGHT	UNIT	PKG QTY	RWL*		STOCK NO.
				5:1	12:1	
1/4"	0.02 LBS/FT	FT	600/1200'	108/45 LBS		502008
5/16"	0.042 LBS/FT	FT	600/1200'	180/75 LBS		502010
3/8"	0.04 LBS/FT	FT	600/1200'	243/101 LBS		502012
1/2"	0.07 LBS/FT	FT	600/1200'	477/199 LBS		502016
5/8"	0.13 LBS/FT	FT	600/1200'	792/330 LBS		502020
3/4"	0.16 LBS/FT	FT	600/1200'	972/405 LBS		502024
1"	0.27 LBS/FT	FT	600/1200'	1,620/675 LBS		502032
1 1/4"	0.41 LBS/FT	FT	600'	2,430/1,013 LBS		502040
1 1/2"	0.60 LBS/FT	FT	600'	3,330/1,388 LBS		502048
2"	1.08 LBS/FT	FT	600'	5,580/2,325 LBS		502064

*** RECOMMENDED WORKING LOAD LIMIT**

NYLON, WHITE 3 STRAND, TWISTED



SIZE	WEIGHT	UNIT	PKG QTY	RWL*		STOCK NO.
				5:1	12:1	
1/4"	0.01 LBS/FT	FT	600/1200'	298/124 LBS		504008
3/8"	0.03 LBS/FT	FT	600/1200'	668/278 LBS		504012
1/2"	0.06 LBS/FT	FT	600/1200'	1,150/479 LBS		504016
5/8"	0.10 LBS/FT	FT	600/1200'	1,800/750 LBS		504020
3/4"	0.14 LBS/FT	FT	600/1200'	2,560/1,067 LBS		504024
1"	0.25 LBS/FT	FT	600/1200'	4,520/1,883 LBS		504032

*** RECOMMENDED WORKING LOAD LIMIT**

⚠ WARNING

To prevent the possibility of serious bodily injury:
*** DO NOT EXCEED** the working load limits

ROPE

NYLON, WHITE 3 STRAND SOLID BRAID



SIZE	WEIGHT	UNIT	PKG QTY	RWL*		STOCK NO.
				5:1	12:1	
1/8" #4	0.004 LBS/FT	FT	1000'	72/30 LBS		504604
3/16" #6	0.012 LBS/FT	FT	1000'	153/64 LBS		504606
1/4" #8	0.016 LBS/FT	FT	1000'	234/98 LBS		504608
5/16" #10	0.02 LBS/FT	FT	500/1000'	351/146 LBS		504610
3/8" #12	0.03 LBS/FT	FT	500/1000'	495/206 LBS		504612
1/2" #16	0.06 LBS/FT	FT	500/1000'	756/315 LBS		504616

*** RECOMMENDED WORKING LOAD LIMIT**

YELLOW POLYPROPYLENE 3 STRAND



SIZE	WEIGHT	UNIT	PKG QTY	RWL*		STOCK NO.
				5:1	12:1	
3/16"	0.007 LBS/FT	FT	600/1200'	144/60 LBS		505006
1/4"	0.012 LBS/FT	FT	600/1200'	226/94 LBS		505008
5/16"	0.018 LBS/FT	FT	600/1200'	342/143 LBS		505010
3/8"	0.028 LBS/FT	FT	600/1200'	488/203 LBS		505012
1/2"	0.047 LBS/FT	FT	600/1200'	756/315 LBS		505016
5/8"	0.075 LBS/FT	FT	600/1200'	1,120/467 LBS		505020
3/4"	0.10 LBS/FT	FT	600/1200'	1,530/638 LBS		505024
1"	0.18 LBS/FT	FT	600/1200'	2,520/1,050 LBS		505032
1 1/4"	0.27 LBS/FT	FT	600'	3,780/1,575 LBS		505040
1 1/2"	0.38 LBS/FT	FT	600'	5,360/2,233 LBS		505048

*** RECOMMENDED WORKING LOAD LIMIT**

3 STRAND POLYPROPYLENE BLACK



SIZE	WEIGHT	UNIT	PKG QTY	RWL*		STOCK NO.
				5:1	12:1	
1/4"	0.012 LBS/FT	FT	600/1200'	226/64 LBS		505108
3/8"	0.028 LBS/FT	FT	600/1200'	488/203 LBS		505112
1/2"	0.04 LBS/FT	FT	600/1200'	756/315 LBS		505116
5/8"	0.07 LBS/FT	FT	600/1200'	1,120/467 LBS		505120

*** RECOMMENDED WORKING LOAD LIMIT**

WARNING

To prevent the possibility of serious bodily injury:
* DO NOT EXCEED the working load limits

ROPE

3 STRAND POLYPROPYLENE YELLOW, YELLOW, MAGENTA



SIZE	WEIGHT	UNIT	PKG QTY	RWL*		STOCK NO.
				5:1	12:1	
5/16"	0.01 LBS/FT	FT	600/1200'	342/143 LBS		505210.1

* RECOMMENDED WORKING LOAD LIMIT

POLY/DAC



SIZE	WEIGHT	UNIT	PKG QTY	RWL*		STOCK NO.
				5:1	12:1	
1/4"	0.016 LBS/FT	FT	600'			505408
1/2"	0.06 LBS/FT	FT	600/1200'	1015/420 LBS		505416
5/8"	0.09 LBS/FT	FT	600/1200'	1400/580 LBS		505420
3/4"	0.135 LBS/FT	FT	600'	1,746/728 LBS		505424
2"	0.81 LBS/FT	FT	600'	11,060/4,608 LBS		505464

* RECOMMENDED WORKING LOAD LIMIT

POLYPROPYLENE LEAVING LINE



SIZE	WEIGHT	UNIT	PKG QTY	RWL*		STOCK NO.
				5:1	12:1	
1 1/2"	0.33 LBS/FT	FT	600'	3,618/1,508 LBS		505648
2"	0.59 LBS/FT	FT	600'	6,318/2,633 LBS		505664

* RECOMMENDED WORKING LOAD LIMIT

SASH CORD COTTON, SOLID BRAID



SIZE	WEIGHT	UNIT	PKG QTY	RWL*	STOCK NO.
1/4" #8	0.01 LBS/FT	RL	100'	150 LBS	501208
5/16" #10	0.03 LBS/FT	RL	100'	240 LBS	501210
3/8" #12	0.36 LBS/FT	RL	100'	300 LBS	501212
7/16" #14	0.32 LBS/FT	RL	100'	465 LBS	501214
1/2" #16	0.44 LBS/FT	RL	100'	540 LBS	501216

* RECOMMENDED WORKING LOAD LIMIT

WARNING

To prevent the possibility of serious bodily injury:
* DO NOT EXCEED the working load limits

ROPE

SHOCK CORD

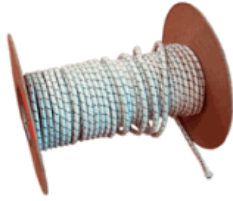

SIZE	WEIGHT	UNIT	PKG QTY	STOCK NO.
1/4"	0.002 LBS/FT	FT	1,000'	508008
5/16"	0.04 LBS/FT	FT	500'	508010
3/8"	0.06 LBS/FT	FT	300'	508012
1/2"	0.10 LBS/FT	FT	150'	508016

SHOCK CORD FITTINGS



SIZE	WEIGHT	UNIT	STOCK NO.
1/4"	0.02 LBS	PR	508508
3/8"	0.04 LBS	PR	508512
1/2"	0.13 LBS	PR	508516

SISAL ROPE



SIZE	WEIGHT	UNIT	PKG QTY	RWL*		STOCK NO.
				5:1	12:1	
1/4"	0.02 LBS/FT	FT	1200'	108/45 LBS		509008
3/8"	0.04 LBS/FT	FT	600'	243/106 LBS		509012
1/2"	0.075 LBS/FT	FT	600'	477/199 LBS		509016
5/8"	0.13 LBS/FT	FT	600'	594/247 LBS		509020

*** RECOMMENDED WORKING LOAD LIMIT**

NYLON SEINE TWINE



SIZE	WEIGHT	UNIT	ROLL QTY	TENSIL STRENGTH	STOCK NO.
#18	0.61 LBS	RL	550'	165 LBS	509602
#21	1.00 LBS	RL	860'	225 LBS	509603
#18	1.00 LBS	RL	1090'	165 LBS	509604

TRANSFORMER SLING



SIZE	WEIGHT	UNIT	BREAKING STRENGTH	STOCK NO.
1/2" X 48"	1.25 LBS	EA	1,225 LBS	509074
5/8" X 48"	1.50 LBS	EA	2,160 LBS	509075

WARNING

To prevent the possibility of serious bodily injury:
 • DO NOT EXCEED the working load limits

SAFETY EQUIPMENT

Waist Belts

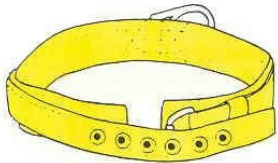

3" Belt/Full Body Pad

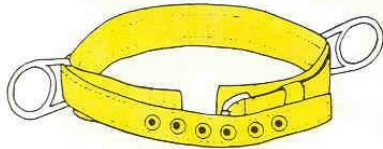

Single or Double D-Ring

Double Action Locking Snap

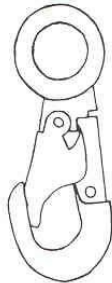

Drop Forged

Full Body Harness

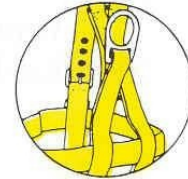

Body Harness
W/1D-Ring

Ladder Hooks



Lanyard Straps

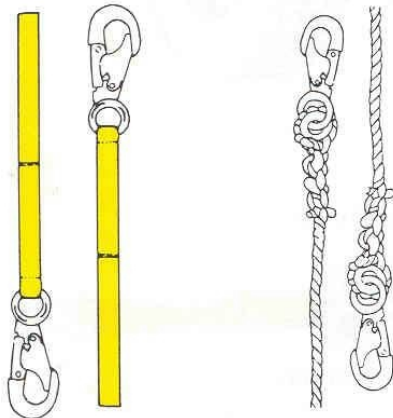

Nylon Web or Rope Construction
Standard Length—6'

Rope Grab

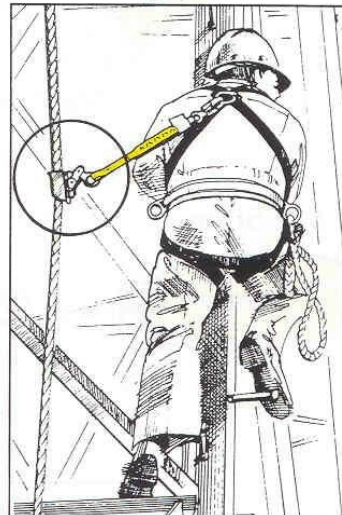

SAFETY EQUIPMENT

SAFETY BELT (FOR POSITIONING ONLY)



SIZE	DESCRIPTION	WEIGHT	UNIT	STOCK NO.
SMALL	BELT W/BODY PAD, DD	1.60 LBS	EA	912005
MEDIUM	BELT W/BODY PAD, DD	1.60 LBS	EA	912006
LARGE	BELT W/BODY PAD, DD	1.70 LBS	EA	912007
X LARGE	BELT W/BODY PAD, DD	1.80 LBS	EA	912008
LARGE	TREE SADDLE	3.11 LBS	EA	912503



CARABINERS

SIZE	DESCRIPTION	WEIGHT	UNIT	STOCK NO.
4"	OFFSET, TWIST LOCK	0.70 LBS	EA	917504
4"	OFFSET, ALUM BLACK	0.30 LBS	EA	917527
3" - 9/16"	"D", ALUM, SILVER	0.30 LBS	EA	917529
3" - 7/16"	LT WT, TWIST LOCK	0.50 LBS	EA	917531

WORKMASTER FULL BODY HARNESS 3D BLUE/YELLOW



SIZE	WEIGHT	UNIT	STOCK NO.
SMALL	4.80 LBS	EA	913065
MEDIUM	4.90 LBS	EA	913066
LARGE	5.10 LBS	EA	913067
X LARGE	5.30 LBS	EA	913068
XX-LARGE	5.50 LBS	EA	913069
XXX-LARGE	5.70 LBS	EA	913070

WARNING

To prevent the possibility of serious bodily injury:
 • **DO NOT EXCEED** the working load limits

SAFETY EQUIPMENT



TOWER SADDLE HARNESS

6-D, ADJUSTABLE

SIZE	WEIGHT	UNIT	STOCK NO.
SMALL	5.10 LBS	EA	913142A
MEDIUM	5.20 LBS	EA	913143A
LARGE	5.30 LBS	EA	913144A
X-LARGE	5.40 LBS	EA	9131441



EAGLE LITE HARNESS

3-D, RED/BLACK

SIZE	WEIGHT	UNIT	STOCK NO.
LARGE	3.60 LBS	EA	913083
X-LARGE	3.70 LBS	EA	913084



FULL BODY HARNESS

SIZE	DESCRIPTION	WEIGHT	UNIT	STOCK NO.
SM-LG	1-D, BLACK/BLUE	2.50 LBS	EA	913110
SM-LG	3-D BLACK/BLUE	3.20 LBS	EA	913100

WARNING

To prevent the possibility of serious bodily injury:
 * **DO NOT EXCEED** the working load limits

SAFETY EQUIPMENT

WEB LANYARDS



REBAR HOOK



LANYARD HOOK



SIZE	LENGTHS*	DESCRIPTION	UNIT	STOCK NO.
1"	6 FT	WEB LANYARD ASSY	EA	913301.6
1"	6 FT	LANYARD ASSY/RH-LH	EA	913302
1"	6 FT	LANYARD W/SHOCK ABSORBER	EA	913303
1"	6 FT	2 WAY SHOCK ASORBER LANYARD	EA	913309

* NOTE: DIFFERENT LENGTHS AVAILABLE ON REQUEST.

LANYARD RETRACTABLE



SIZE	DESCRIPTION	WEIGHT	UNIT	STOCK NO.
3/16" X 25'	SELF RETRACTABLE	18.00 LBS	EA	913384
3/16" X 50'	RETRACTABLE	20.00 LBS	EA	913385
3/16" X 100'	RETRACTABLE	28.00 LBS	EA	913386

HARD HAT



COLORS	WEIGHT	UNIT	STOCK NO.
WHITE, YELLOW, BLUE, GREEN	0.90 LBS	EA	914001
RATCHETING TYPE	0.90 LBS	EA	914101
FULL BRIM, RAT TYPE	0.90 LBS	EA	914111

CAUTION TAPE



SIZE	WEIGHT	UNIT	STOCK NO.
3"X200'	3.00 LBS	RL	913989
3" X 1000'	3.00 LBS	RL	913991

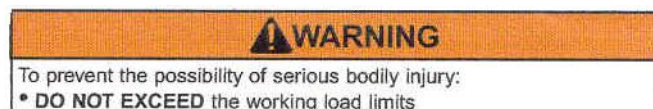

SAFETY EQUIPMENT

SAFETY GLASSES



DESCRIPTION	WEIGHT	UNIT	STOCK NO.
PLASTIC FRAME, CLEAR LENS	0.07 LBS	PR	916010
BLUE FRAME, CLEAR LENS	0.06 LBS	PR	916012
BLACK FRAME, CLEAR LENS	0.06 LBS	PR	916015
BLACK FRAME, GREY LENS	0.06 LBS	PR	916016
BLACK FRAME, AMBER LENS	0.06 LBS	PR	916018
RED/WHITE/BLUE FRAME, CLEAR LENS	0.06 LBS	PR	916020
RED/WHITE/BLUE FRAME, GREY LENS	0.06 LBS	PR	916021
RED/WHITE/BLUE FRAME, MIRROR LENS	0.06 LBS	PR	916022
CLEAR COMFORTABLE STYLE	0.06 LBS	PR	916025
GREY COMFORT STYLE	0.06 LBS	PR	916026
WRAP AROUND, CLEAR LENS	0.10 LBS	PR	916040
WRAP AROUND, GREY LENS	0.10 LBS	PR	916042
GOGGLES	0.10 LBS	PR	916030
GOGGLES WITH MASK	0.18 LBS	PR	916032

KLEIN® SAFETY GLASSES



DESCRIPTION	KLEIN PART NO.	WEIGHT	UNIT	STOCK NO.
BLACK FRAME, BROWN LENS	60055	0.06 LBS	PR	916036
BLACK FRAMELESS, CLEAR LENS	60056	0.06 LBS	PR	916037
BLACK FRAMELESS, BROWN LENS	60057	0.06 LBS	PR	916038

EAR PLUG



DESCRIPTION	WEIGHT	UNIT	PKGQTY	STOCKNO.
UNCORDED	0.10 LBS	PR	50	914003
CORDED	0.10 LBS	PR	50	914004

WARNING

To prevent the possibility of serious bodily injury:
 * DO NOT EXCEED the working load limits

SAFETY EQUIPMENT



TRAFFIC SAFETY CONE

SIZE	DESCRIPTION	WEIGHT	UNIT	STOCK NO.
18"	ORANGE	3.50 LBS	EA	913992
28"	ORANGE	4.25 LBS	EA	913994
28"	2 REFLECTIVE STRIPES	4.25 LBS	EA	913995



SAFETY VEST

SIZE	DESCRIPTION	WEIGHT	UNIT	STOCK NO.
SM/LG	ORANGE	0.20 LBS	EA	913993
SM/LG	REF STRIPE FRONT/BACK	0.25 LBS	EA	913996

FLAG



SIZE	DESCRIPTION	WEIGHT	UNIT	STOCK NO.
18" X 18"	RED BANNER FLAG	0.25 LBS	EA	913998
60'	YELLOW PENNANT 36 FLAGS	0.50 LBS	PG	913999
60'	RED PENNANT 36 FLAGS	0.50 LBS	PG	914000



RAIN SUIT 3 PIECE YELLOW

SIZE	WEIGHT	UNIT	STOCK NO.
MEDIUM	3.10 LBS	EA	415100
LARGE	3.25 LBS	EA	415110
X-LARGE	3.25 LBS	EA	415120
2X-LARGE	3.35 LBS	EA	415130
3X-LARGE	3.50 LBS	EA	415140
4X-LARGE	3.60 LBS	EA	415150

WARNING

To prevent the possibility of serious bodily injury:
 • **DO NOT EXCEED** the working load limits



TOOL BAG & BUCKET



SIZE	DESCRIPTION	KLEIN PART NO	WEIGHT	UNIT	STOCK NO.
5"X9"X10"	BOLT BAG, CANVAS, 2 LOOP WRENCH HOLDERS	5416	1.00 LBS	EA	475064
5"X9"X10"	BOLT BAG,CANVAS, 1 SOLID LOOP, WRENCH HOLDERS	5416T	0.90 LBS	EA	475069
9" X 10"	CANVAS UTILITY BAG W/SIDE POCKETS	5142P	0.85 LBS	EA	475065
5"X8 1/2"X8 1/2"	LEATHER BOLT BAG WITH WRENCH HOLDERS	42247	0.80 LBS	EA	475066
2 1/2" X 12"	CANVAS ELECTRODE BAG	5471	0.40 LBS	EA	475063
10"X12"X5"	CANVAS UTILITY BAG WITH INSIDE POCKET	5141P	1.20 LBS	EA	475050
12" X 17"	CANVAS BUCKET W/LEATHER BOTTOM	5104	2.95 LBS	EA	475068
15" X 8"	CANVAS GLOVE BAG	5124-15	0.64 LBS	EA	413354

TOOL POCHE/HOLDER & BELT



SIZE	DESCRIPTION	KLEIN PART NO.	WEIGHT	UNIT	STOCK NO.
3 1/4" X 12 1/4"	LEATHER BULL PIN HOLDER	5417T	0.45 LBS	EA	475062
6" X 9 1/2"	WRENCH HOLDER, CANVAS	5461T	0.35 LBS	EA	485989
6" X 9 1/2"	WRENCH HOLDER, LEATHER	5459T	0.35 LBS	EA	485990
1 1/4" X 9"	HOLDER, LOOP WITH SNAP HOOK	5458	0.15 LBS	EA	485991
N/A	4 POCKET LEATHER TOOL POUCH	5118C	0.80 LBS	EA	475040
N/A	6 POCKET LEATHER TOOL POUCH	5127	0.74 LBS	EA	475047
SMALL	LEATHER BELT, HD, WIRE TIE REEL	5415S	0.80 LBS	EA	911910
36"-45"	LEATHER BELT, HD, EXTRA WIDE	5415	0.75 LBS	EA	911911
32"-40"	LEATHER BELT, HD IRON WORKERS	5420S	0.85 LBS	EA	911915
36"-44"	LEATHER BELT, HD IRON WORKERS	5420	1.20 LBS	EA	911916
40"-48"	LEATHER BELT, HD IRON WORKERS	5420L	1.25 LBS	EA	911917
44"-52"	LEATHER BELT, HD IRON WORKERS	5420XL	1.40 LBS	EA	911918

WARNING

To prevent the possibility of serious bodily injury:
 • **DO NOT EXCEED** the working load limits

CONNECTING BAR



SIZE	SHAPE	WEIGHT	KLEIN PART NO.	UNIT	STOCK NO.
3/4" X 24"	HEX	2.80 LBS	3244	EA	490613
3/4" X 24"	ROUND	2.45 LBS	3247	EA	490615
3/4" X 30"	HEX	1.25 LBS	3242	EA	490616
3/4" X 30"	HEX, CHISEL END	3.80 LBS	3240	EA	490620
3/4" X 30"	ROUND	3.30 LBS	3245	EA	490625
7/8" X 30"	ROUND	4.30 LBS	3248	EA	490630
7/8" X 36"	HEX	5.85 LBS	3243	EA	490614
7/8" X 36"	ROUND	5.40 LBS	3246	EA	490617

BROAD HEAD & DRIFT PIN



SIZE	DESCRIPTION	WEIGHT	KLEIN PART NO.	UNIT	STOCK NO.
11/16"X7 1/2"	DRIFT PIN	1.00 LBS	3260	EA	475390
13/16"X8"	DRIFT PIN	0.85 LBS	3261	EA	475391
15/16"X8"	DRIFT PIN	1.70 LBS	3262	EA	475392
1 1/16"X8"	DRIFT PIN	2.00 LBS	3263	EA	475393
1 1/16"X10"	BROAD HEAD BULL	2.00 LBS	3256	EA	475380
1 1/4"X13"	BROAD HEAD BULL	3.35 LBS	3255	EA	475379



SPUD WRENCH



SIZE	DESCRIPTION	WEIGHT	KLEIN PART NO.	UNIT	STOCK NO.
1/2"	RATCHET SPUD	2.10 LBS	3238	EA	485800
UP TO 1 1/2"	ADJUSTABLE SPUD	2.10 LBS	3239	EA	485801
7/8"	ERECTION SPUD HVY DUTY	1.70 LBS	3210	EA	485828
1"	ERECTION SPUD HVY DUTY	1.31 LBS	3221	EA	485832
1 1/16"	ERECTION SPUD HVY DUTY	1.75 LBS	3211	EA	485834
1 1/8"	ERECTION SPUD HVY DUTY	2.20 LBS	3222	EA	485836
1 1/4"	ERECTION SPUD HVY DUTY	2.20 LBS	3212	EA	485840
1 5/16"	ERECTION SPUD HVY DUTY	2.87 LBS	3223	EA	485842
1 7/16"	ERECTION SPUD HVY DUTY	2.50 LBS	3213	EA	485846
1 1/2"	ERECTION SPUD HVY DUTY	3.37 LBS	3224	EA	485848
1 5/8"	ERECTION SPUD HVY DUTY	2.70 LBS	3214	EA	485852

WARNING

To prevent the possibility of serious bodily injury:
 * DO NOT EXCEED the working load limits

PLIERS



SIZE	DESCRIPTION	WEIGHT	KLEIN PART NO	UNIT	STOCK NO.
9 1/4"	PLIERS SIDE CUT, HIGH LEVERAGE	1.15 LBS	D2000-9NE	EA	475365
9 1/4"	PLIERS SIDE CUT, HIGH LEVERAGE	1.40 LBS	D213-9NE	EA	475394
9 9/32"	SIDE CUTTING FOR REBAR WORK	1.15 LBS	D213-9ST	EA	475395
10"	WATER PUMP PLIERS	1.05 LBS	D502-10	EA	475396
8"	DIAGONAL CUT, PLASTIC-DIPPED HANDLES	0.95 LBS	D228-8	EA	475398
8 5/16"	HD, LONG NOSE, SIDE CUT	0.85 LBS	D203-8N	EA	475399
7 5/16"	PLIERS, SIDE CUT NE TYPE	0.60 LBS	D201-7NE	EA	475407
8"	DIAGONAL CUT, ANGLED HEAD	1.00 LBS	D248-8	EA	475409
9"	DIAGONAL CUT, ANGLED HEAD, FOR REBAR WORK	1.00 LBS	D248-9ST	EA	475412
8 3/4"	SIDE CUTTING FOR REBAR WORK	0.63 LBS	D2000-7CST	EA	475419
8 3/4"	SIDE CUTTING REBAR	0.60 LBS	D201-7CST	EA	475408
9 9/32"	SIDE CUTTING FOR REBAR WORK, HEAVY DUTY	2.45 LBS	D2000-9ST	EA	475428



SCREWDRIVER



SIZE	DESCRIPTION	WEIGHT	KLEIN PART NO.	UNIT	STOCK NO.
5/16" X 6"	STRAIGHT, CUSHION GRIP	0.70 LBS	600-6	EA	475566
3/8" X 8"	STRAIGHT, CUSHION GRIP	0.70 LBS	600-8	EA	475567
7"	#2 PHILLIPS, CUSHION GRIP	0.30 LBS	603-7	EA	475569

PUNCH PIN



SIZE	WEIGHT	KLEIN PART NO.	UNIT	STOCK NO.
3/32"	0.08 LBS	66321	EA	475439-1
1/8"	0.10 LBS	66322	EA	475439-2
5/32"	0.10 LBS	66323	EA	475439-3
3/16"	0.10 LBS	66324	EA	475439-4

WARNING

To prevent the possibility of serious bodily injury:
 • **DO NOT EXCEED** the working load limits

GRIPS

KLEIN® GRIP – CABLE/WIRE ROPE



SIZE	DESCRIPTION	KLEIN PART NO.	WEIGHT	UNIT	WORKING LOAD LIMIT	STOCK NO.
.08 - .20	ROPE GRIP, BARE WIRE	1613-30	1.50 LBS	EA	1,500 LBS	901504.3
.20 - .42	CABLE GRIP-PVC CONDUCTOR	1659-20	3.00 LBS	EA	4,500 LBS	901516
.125 - .50	CABLE GRIP WITH LATCH, STEEL STRAND	1604-20L	2.50 LBS	EA	5,000 LBS	901507
.125 - .50	CABLE GRIP WITHOUT LATCH, STEEL STRAND	1604-20	2.50 LBS	EA	5,000 LBS	901518
.20 - .40	CABLE GRIP/PARALLEL JAW	1686-20	4.50 LBS	EA	10,000 LBS	901535
.28 - .75	WIRE ROPE GRIP	1625-20	3.50 LBS	EA	8,000 LBS	901504
.37 - .75	PARALLEL JAW	1672-10	5.00 LBS	EA	10,000 LBS	901509
.50 - 1.0	WIRE ROPE HAVEN	1625-20/1	3.50 LBS	EA	8,000 LBS	901532
1.24-1.54	CONDUCTOR/CABLE	1628-40	34.00 LBS	EA	25,000 LBS	901534

WIRE MESH GRIP (CHINESE STYLE)



SIZE	WEIGHT	UNIT	BREAKING STRENGTH	STOCK NO.
1/2" - 9/16"	0.10 LBS	EA	770 LBS	901514
5/8" - 3/4"	0.10 LBS	EA	1,150 LBS	901511
3/4" - 1"	0.10 LBS	EA	1,320 LBS	901512
1" - 1 1/4"	0.25 LBS	EA	1,920 LBS	901513

⚠ WARNING

To prevent the possibility of serious bodily injury:
 • **DO NOT EXCEED** the working load limits

GLOVES

LEATHER DRIVERS



SIZES	DESCRIPTION	WEIGHT	UNIT	CASE PKG	STOCK NO.
LARGE	LEATHER DRIVING	0.20 LBS	PR	10 DZ	413103
XLARGE	LEATHER DRIVING	0.20 LBS	PR	10 DZ	413104
LARGE	LEATHER DRIVERS PULL STRAP	0.25 LBS	PR	10 DZ	413110
MED/LG/XLG	PIGSKIN DRIVERS	0.18 LBS	PR	10 DZ	413112
LARGE	DBL PALM VINYL STR YELLOW/BRN	0.45 LBS	PR	25 DZ	413550

RUST DRIVERS, FLEECE LINED



SIZE	WEIGHT	UNIT	CASE PKG	STOCK NO.
SMALL	0.30 LBS	PR	10 DZ	413116
MEDIUM	0.30 LBS	PR	10 DZ	413113
LARGE	0.45 LBS	PR	10 DZ	413114
XLARGE	0.45 LBS	PR	10 DZ	413115



JERSEY

SIZE	DESCRIPTION	WEIGHT	UNIT	CASE PKG	STOCK NO.
9 OZ	BROWN JERSEY,KNIT WRIST	0.10 LBS	PR	25 PR	413200
9 OZ	RED LINED	0.15 LBS	PR	12 PR	413205

⚠ WARNING

To prevent the possibility of serious bodily injury:
 • DO NOT EXCEED the working load limits

GLOVES

RUBBER GLOVES



SIZE	DESCRIPTION	WEIGHT	UNIT	CASE PKG	STOCK NO.
LG	GREEN NITRILE	0.58 LBS	PR	12 DZ	413432
13"	GREEN NITRILE, 16 MIL, FLOCK LINED	0.45 LBS	PR	12 DZ	413435
14"	ORANGE LINED, SMOOTH	0.58 LBS	PR	6 DZ	413411
14"	ORANGE LINED, ROUGH	0.55 LBS	PR	6 DZ	413410
18"	ORANGE LINED, ROUGH	0.55 LBS	PR	6 DZ	413418
14"	GAUNTLET, PVC	0.50 LBS	PR	10 DZ	413401
14"	BLACK, PVC DIPPED	0.25 LBS	PR	10 DZ	413400

WELDING GLOVES



SIZE	DESCRIPTION	WEIGHT	UNIT	CASE PKG	STOCK NO.
LARGE	GREY GOATSKIN	0.17 LBS	PR	6 DZ	413601
LARGE	BLUE, WELDING	0.60 LBS	PR	6 DZ	413610

WORK GLOVES



SIZE	DESCRIPTION	WEIGHT	UNIT	CASE PKG	STOCK NO.
LARGE	LEATHER PALM RUBBER CUFF	0.41 LBS	PR	10 DZ	413105
LARGE	RUSSETT, LEATHER PALM	0.45 LBS	PR	10 DZ	413100
LARGE	LEATHER, LONG PLASTIC CUFF	0.19 LBS	PR	6 DZ	413108

WARNING

To prevent the possibility of serious bodily injury:
 • DO NOT EXCEED the working load limits

SHOVELS

SHOVEL



SIZE	DESCRIPTION	WEIGHT	UNIT	STOCK NO.
11"	GENERAL STREET	4.50 LBS	EA	495601
4"	TRENCHING, LONG FIBERGLASS HANDLE	4.00 LBS	EA	495603
14"	SNOW, STEEL FLAT, D HANDLE	4.20 LBS	EA	495604
#2	DIRT, ALUMINUM, D HANDLE	2.75 LBS	EA	495605
#2	ROUND POINT, LONG HANDLE	3.90 LBS	EA	495620
#2	SQUARE POINT, LONG HANDLE	3.80 LBS	EA	495630
#2	ROUND POINT, "D" HANDLE	4.00 LBS	EA	495670
#2	SQUARE POINT, "D" HANDLE	4.30 LBS	EA	495680
#2	ROUND POINT, FIBERGLASS LONG HANDLE	4.80 LBS	EA	495720
#2	SQUARE POINT, FLIBERGLASS LONG HANDLE	5.00 LBS	EA	495730
#2	ROUND POINT, FIBERGLASS "D" HANDLE	4.20 LBS	EA	495770
#2	SQUARE POINT, FIBERGLASS "D" HANDLE	4.20 LBS	EA	495780
#2	ALUMINUM, 48" HANDLE	3.25 LBS	EA	495810LH

COAL SHOVEL



SIZE	DESCRIPTION	WEIGHT	UNIT	STOCK NO.
#4	BUG DUST, STEEL, 6' HANDLE	6.00 LBS	EA	495606
#4	BUG DUST, STEEL, 8' HANDLE	8.25 LBS	EA	495608
#4	9" LIFT, STEEL, COAL 209-4E, D HANDLE	7.00 LBS	EA	495610
#4	11" LIFT, STEEL, COAL 211-4E, D HANDLE	7.00 LBS	EA	495611
#4	14" LIFT, STEEL, COAL 214-4E, D HANDLE	7.25 LBS	EA	495614
#4	21" LIFT, STEEL, COAL 221-4E, D HANDLE	6.50 LBS	EA	495619
#2	STEEL, COAL, HIGH VANE DOMESTIC, D HANDLE	7.00 LBS	EA	495619D
#2	11" LIFT, ALUMINUM, LONG HANDLE	3.50 LBS	EA	495811LH
#4	11" LIFT, COAL, ALUMINUM LOW VANE	4.00 LBS	EA	495813
#2	21" LIFT, COAL, ALUMINUM HIGH VANE, D HANDLE	3.75 LBS	EA	495819

WARNING

To prevent the possibility of serious bodily injury:
 * DO NOT EXCEED the working load limits

SHOVELS

SPADE



SIZE	DESCRIPTION	WEIGHT	UNIT	STOCK NO.
5"	TRACK, WOOD HANDLE	4.00 LBS	EA	495600

SCOOP



SIZE	DESCRIPTION	WEIGHT	UNIT	STOCK NO.
#4	STEEL, LONG HANDLE	6.37 LBS	EA	495527
#6	STEEL, LONG HANDLE	6.37 LBS	EA	495528
#8	STEEL, LONG HANDLE	6.40 LBS	EA	495529
#14	ALUM, LONG HANDLE	6.31 LBS	EA	495540
#12	STEEL, "D" HANDLE	6.43 LBS	EA	495512
14"	"D" HANDLE, GRAIN, ABS PLASTIC	4.25 LBS	EA	495500
#2	ASPHALT, "D" HANDLE	5.75 LBS	EA	495550
#10	ALUM, "D" HANDLE	6.25 LBS	EA	495580
#12	SCOOP, BAG, ALUM, D HANDLE	6.25 LBS	EA	495585
#14	ALUM, "D" HANDLE	6.25 LBS	EA	495590

HANDLES WOOD & FIBERGLASS



SIZE	DESCRIPTION	WEIGHT	UNIT	STOCK NO
38"	"D" WOOD	1.50 LBS	EA	495939
27"	"D" WOOD #2 SHOVEL	1.50 LBS	EA	495940
38"	"D" FIBERGLASS	1.75 LBS	EA	495941
32"	"D" WOOD	1.75 LBS	EA	495942
19"	FIBERGLASS FOR #2 ALUM COAL SHOVEL	1.50 LBS	EA	495490FG
48"	ALUM, COAL SHOVEL LONG HANDLE	2.30 LBS	EA	495924
48"	YELLOW FIBERGLASS D HANDLE	2.30 LBS	EA	495924FG
6'	BUG DUST	2.40 LBS	EA	495936
8'	BUG DUST	3.50 LBS	EA	495938

WARNING

To prevent the possibility of serious bodily injury:
 * DO NOT EXCEED the working load limits

BARS

PINCH POINT BAR (CROWBAR)



SIZE	DESCRIPTION	WEIGHT	UNIT	STOCK NO.
#6	PINCH POINT BAR 7/8" X'36"	6.00 LBS	EA	490506
#10	PINCH POINT BAR 1" X 48"	8.00 LBS	EA	490510
#12	PINCH POINT BAR 1" X 50"	12.00 LBS	EA	490512
#14	PINCH POINT BAR 1 1/4" X 54"	14.00 LBS	EA	490514
#16	PINCH POINT BAR 1 1/4" X 58"	16.50 LBS	EA	490516
#18	PINCH POINT BAR 1 1/4" X 60"	18.00 LBS	EA	490518
#22	PINCH POINT BAR 1 3/8" X 64"	22.00 LBS	EA	490522
#26	PINCH POINT BAR 1 1/2" X 66"	26.00 LBS	EA	490526

PRY BAR



SIZE	DESCRIPTION	WEIGHT	UNIT	STOCK NO.
4 PCS	SNAP ON 4 PC SET	3.40 LBS	EA	490710
4 PCS	MECHANICS 4 PC SET	4.75 LBS	EA	490711

ROLLING HEAD BAR



SIZE	DESCRIPTION	WEIGHT	UNIT	STOCK NO.
3/8" X 9"	ROLLING HEAD BAR	0.25 LBS	EA	490610
5/8" X 18"	ROLLING HEAD BAR	0.50 LBS	EA	490612

SLATE BAR (ORANGE)



SIZE	DESCRIPTION	WEIGHT	UNIT	STOCK NO.
36"	SLATE - PRY BAR, 1" HEX	8.25 LBS	EA	490736
48"	SLATE - PRY BAR, 1" HEX	11.00 LBS	EA	490748
54"	SLATE - PRY BAR, 1" HEX	13.00 LBS	EA	490754
60"	SLATE - PRY BAR, 1" HEX	14.00 LBS	EA	490760
72"	SLATE - PRY BAR, 1" HEX	15.00 LBS	EA	490772

WARNING

To prevent the possibility of serious bodily injury:
 • **DO NOT EXCEED** the working load limits

BARS

TAMPING BAR, POST HOLE DIGGER



SIZE	DESCRIPTION	WEIGHT	UNIT	STOCK NO.
#17	POST HOLE TAMPING BAR 6'	17.00 LBS	EA	490951

WONDER BAR



SIZE	DESCRIPTION	WEIGHT	UNIT	STOCK NO.
18"	WONDER BAR	1.75 LBS	EA	490208

WRECKING BAR



SIZE	DESCRIPTION	WEIGHT	UNIT	STOCK NO.
3/4" X 24"	WRECKING BAR GOOSENECK	3.25 LBS	EA	490215
3/4" X 36"	WRECKING BAR GOOSENECK	4.60 LBS	EA	490217
1" X 48"	WRECKING BAR GOOSENECK	13.00 LBS	EA	490225

WARNING

To prevent the possibility of serious bodily injury:
• **DO NOT EXCEED** the working load limits

AGRICULTURE TOOLS

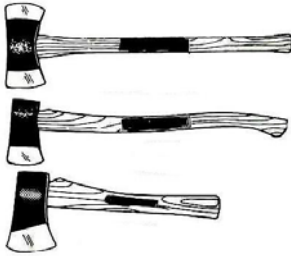

AXE

SIZE	DESCRIPTION	WEIGHT	UNIT	CASE PKG	STOCK NO.
2.5 LBS	BOYS, SINGLE BIT	3.50 LBS	EA	12	497111
3.5 LBS	MINERS SHORT HNDL	4.25 LBS	EA	6	497150
2.5 LBS	DOUBLE BIT	3.50 LBS	EA	12	497161
3.5 LBS	DOUBLE BIT	4.75 LBS	EA	10	497191
5.3 LBS	PULASKI	5.30 LBS	EA	1	497198



FLAT COAL PICK

SIZE	DESCRIPTION	WEIGHT	UNIT	STOCK NO.
#4	WITH HANDLE	4.00 LBS	EA	495324

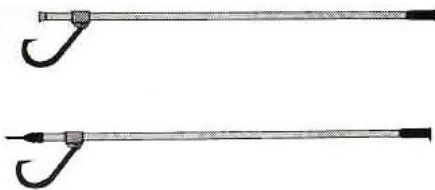

CANT HOOK

SIZE	DESCRIPTION	WEIGHT	UNIT	STOCK NO
2 1/4" X 3'	CANT HOOK	6.00 LBS	EA	903010
2 1/4" X 3 1/2'	CANT HOOK	6.50 LBS	EA	903008
2 1/4" X 4'	CANT HOOK	7.00 LBS	EA	903011
2 1/2" X 4'	CANT HOOK	8.50 LBS	EA	903005
2 1/2" X 5'	CANT HOOK	10.00 LBS	EA	903013
2 1/2" X 5'	PEAVY HOOK	10.00 LBS	EA	903025



FORK

SIZE	DESCRIPTION	WEIGHT	UNIT	CASE PKG	STOCK NO
15"	COTTON SEED	7.30 LBS	EA	3	495141
4 TINE	HAY PITCH	3.50 LBS	EA	3	495143
5 TINE	HAY PITCH	3.10 LBS	EA	3	495145
4 TINE	SPADING, WELDED	3.50 LBS	EA	3	495146

WARNING

To prevent the possibility of serious bodily injury:
 * DO NOT EXCEED the working load limits

AGRICULTURE TOOLS

MATTOCK - CUTTER

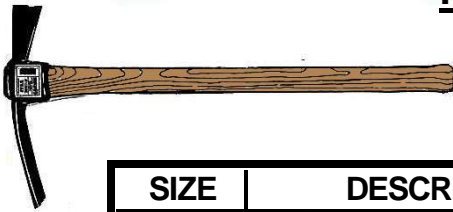

SIZE	DESCRIPTION	WEIGHT	UNIT	STOCK NO.
3 LB	CUTTER W/36" HANDLE	4.50 LBS	EA	495303
5 LB	CUTTER W/36" HANDLE	8.25 LBS	EA	495305

MATTOCK - PICK

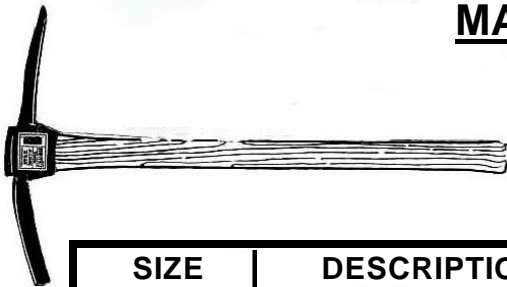

SIZE	DESCRIPTION	WEIGHT	UNIT	STOCK NO.
2 1/2 LB	WITH 36" HANDLE	4.00 LBS	EA	495332
5 LB	WITH 36" HANDLE	7.00 LBS	EA	495335

CUTTER & PICK MATTOCK –HEAD & HANDLES



SIZE	DESCRIPTION	WEIGHT	UNIT	STOCK NO.
#3	CUTTER MATTOCK, 3LB	3.00 LBS	EA	495953
#5	CUTTER MATTOCK, 5 LB	5.00 LBS	EA	495955
#5	PICK, 5 LB	5.00 LBS	EA	495957
#6	PICK, 6 LB	6.00 LBS	EA	495958
#1	PICK, 1 LB	3.96 LBS	EA	495960
36"	#3 HANDLE CUTTER MATTOCK	1.50 LBS	EA	495906
36"	#5 HANDLE CUTTER & PICK HEAD	1.50 LBS	EA	495905

WARNING

To prevent the possibility of serious bodily injury:
 • DO NOT EXCEED the working load limits

AGRICULTURE TOOLS



POST HOLE DIGGER

SIZE	DESCRIPTION	WEIGHT	UNIT	STOCK NO.
48"	6" HOLE	8.00 LBS	EA	490950
60"	7" HOLE	11.00 LBS	EA	490952



RAKE

SIZE	DESCRIPTION	WEIGHT	UNIT	STOCK NO.
36"	ASPHALT LUTE	5.70 LBS	EA	495408
16 1/2"	ASPHALT, 60" HANDLE	6.66 LBS	EA	495409
17 7/8"	HEAVY DUTY 16 TINE BOW	4.60 LBS	EA	495410
15 1/2"	HEAVY DUTY, 14 TINE BOW	3.30 LBS	EA	495412
21"	LEAF RAKE	2.25 LBS	EA	495430
16 1/2"	ROAD & STONE (FIRE)	4.50 LBS	EA	495440

HOE

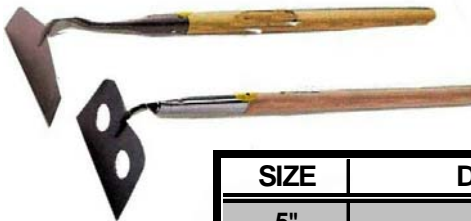

SIZE	DESCRIPTION	WEIGHT	UNIT	STOCK NO.
5"	GARDEN	2.20 LBS	EA	495210
7"	GARDEN	2.30 LBS	EA	495220
7"	MORTAR MIXER SMALL	2.60 LBS	EA	495224
10"	MORTAR MIXER LARGE	4.30 LBS	EA	495225

WARNING

To prevent the possibility of serious bodily injury:
 • DO NOT EXCEED the working load limits

AGRICULTURE TOOLS

SCRAPER



SIZE	DESCRIPTION	WEIGHT	UNIT	STOCK NO.
3"	ICE, 48" HANDLE	3.50 LBS	EA	495470
6"	SIDEWALK, 48" HANDLE	2.50 LBS	EA	495465
10"	SIDEWALK, 48" HANDLE	4.00 LBS	EA	495460



TONG W/ RING

TONG



TONG W/ HOOK

SIZE	DESCRIPTION	WEIGHT	UNIT	STOCK NO.
3/4" X 16"	ALLOY LIFTING TONG WITH RING	6.75 LBS	EA	902500
1" X 20"	ALLOY LIFTING TONG WITH RING	14.25 LBS	EA	902501
1" X 25"	ALLOY LIFTING TONG WITH RING	16.45 LBS	EA	902502
3/4" X 16"	SKIDDING TONG WITH RING	6.00 LBS	EA	902520
1" X 20"	SKIDDING TONG WITH RING	12.25 LBS	EA	902521
1" X 25"	SKIDDING TONG WITH RING	16.00 LBS	EA	902522
1" X 20"	SKIDDING TONG WITH SWIVEL HOOK	13.25 LBS	EA	902531
1 1/4" X 32"	SKIDDING TONG WITH SWIVEL HOOK	34.00 LBS	EA	902533

WARNING

To prevent the possibility of serious bodily injury:
 * DO NOT EXCEED the working load limits

FARM ACCESSORIES

CLEVIS, ORANGE



PIN SIZE	STYLE	WEIGHT	UNIT	WORKING LOAD LIMIT	STOCK NO.
5/8"	STRAIGHT	1.50LBS	EA	12,000 LBS	556920
5/8"	TWISTED	1.50 LBS	EA	12,000 LBS	557020
3/4"	STRAIGHT	3.00 LBS	EA	16,000 LBS	556924
3/4"	TWISTED	3.00 LBS	EA	16,000 LBS	557024
7/8"	STRAIGHT	3.50 LBS	EA	20,000 LBS	556928
7/8"	TWISTED	3.50 LBS	EA	20,000 LBS	557028

NOTE: NOT FOR OVERHEAD LIFTING

CLEVIS GENERAL PURPOSE



SIZE	WEIGHT	UNIT	STOCK NO.
3/4"	3.00 LBS	EA	554524

NOTE: NOT FOR OVERHEAD LIFTING

FENCING PLIERS



SIZE	WEIGHT	UNIT	STOCK NO.
10 1/2"	1.71 LBS	EA	475413

HITCH PINS (INTERNATIONAL)



SIZE	LENGTH	WEIGHT	UNIT	STOCK NO.
3/8"	4 3/8"	0.17 LBS	EA	430872
7/16"	3 1/2"	0.30 LBS	EA	430874
1/2"	4 1/4"	0.39 LBS	EA	430876
5/8"	6 1/2"	0.74 LBS	EA	430880
3/4"	4 1/2"	1.10 LBS	EA	430883
3/4"	4"	0.87 LBS	EA	430884CM
3/4"	6 1/4"	1.10 LBS	EA	430884
7/8"	6 1/2"	1.50 LBS	EA	430888
1"	6 3/4"	1.80 LBS	EA	430892

WARNING

To prevent the possibility of serious bodily injury:
 • **DO NOT EXCEED** the working load limits

FARM ACCESSORIES



POST DRIVER WITH HANDLES

SIZE	WEIGHT	UNIT	STOCK NO.
32"	2.00 LBS	EA	490940
36"	21.00 LBS	EA	490941



TOP LINK

SIZE	WEIGHT	UNIT	STOCK NO.
CAT. I	7.25 LBS	EA	430901
CAT. II	9.00 LBS	EA	430902

WIRE STRETCHER/SPLICER



SIZE	WEIGHT	UNIT	STOCK NO.
#1	8.00 LBS	EA	901302

LYNCH PIN



SIZE	WEIGHT	UNIT	STOCK NO.
3/16"	0.05 LBS	EA	430856
1/4"	0.06 LBS	EA	430858
5/16"	0.07 LBS	EA	430860
7/16"	0.11 LBS	EA	430864



WHEELBARROW

SIZE	DESCRIPTION	WEIGHT	UNIT	STOCK NO.
6 CU FT	16"X14"	21.00 LBS	EA	475830

WARNING

To prevent the possibility of serious bodily injury:
 * DO NOT EXCEED the working load limits

PINS

ADJUSTABLE CLEVIS PIN



SIZE	WEIGHT	UNIT	PKG QTY	STOCK NO.
1/4" X 2"	0.03 LBS	EA	100	658407
1/4" X 3"	0.045 LBS	EA	100	658408
7/16" X 2"	0.093 LBS	EA	100	658414

CLEVIS PIN



SIZE	WEIGHT	UNIT	PKG QTY	STOCK NO.
3/8" X 2 3/4"	0.044 LBS	EA	100	657912
7/16" X 2 3/4"	0.125 LBS	EA	100	657914

STEEL COTTER PIN



SIZE	WEIGHT	UNIT	PKG QTY	STOCK NO.
1/16" X 1"	0.001 LBS	EA	100	658202
3/32" X 2"	0.004 LBS	EA	100	658203
1/8" X 2 1/2"	0.009 LBS	EA	100	658204
5/32" X 2 1/2"	0.014 LBS	EA	100	658205
3/16" X 2 1/2"	0.021 LBS	EA	100	658206
1/4" X 3"	0.042 LBS	EA	100	658208
5/16" X 4"	0.092 LBS	EA	100	658210
5/16" X 5"	0.095 LBS	EA	100	658211
3/8" X 4"	0.136 LBS	EA	100	658212
3/8" X 6"	0.186 LBS	EA	100	658213
1/2" X 6"	0.385 LBS	EA	100	658216

HAIRPIN COTTER



SIZE	SHAFT SIZE	WEIGHT	UNIT	PKG QTY	STOCK NO.
1/16"	3/16"-1/4"	0.002 LBS	EA	100	656801
3/64"	5/16"-3/8"	0.004 LBS	EA	100	656802
3/32"	3/8"-7/16"	0.009 LBS	EA	100	656803
1/8"	1/2"-5/8"	0.019 LBS	EA	100	656804
5/32"	5/8"-3/4"	0.031 LBS	EA	100	656805
3/16"	1 1/8"-1 1/2"	0.058 LBS	EA	100	656806
1/4"	1 1/8"-1 1/2"	0.15 LBS	EA	100	656808
5/16"	N.A	0.175 LBS	EA	100	656810

WARNING

To prevent the possibility of serious bodily injury:
 • DO NOT EXCEED the working load limits

PINS

COTTERLESS HITCHPIN



SIZE	LENGTH	WEIGHT	UNIT	PKG QTY	STOCK NO.
1/4"	1 1/2"	0.02 LBS	EA	100	657708
1/4"	2"	0.02 LBS	EA	100	657709
5/16"	2"	0.041 LBS	EA	100	657710
5/16"	3"	0.061 LBS	EA	100	657711
3/8"	2 1/2"	0.074 LBS	EA	100	657712
3/8"	3 1/2"	0.10 LBS	EA	100	657713
1/2"	2 1/2"	0.15 LBS	EA	100	657715
1/2"	3"	0.175 LBS	EA	100	657716

SNAPPER PIN ROUND LOCKING

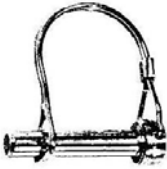

SIZE	WEIGHT	UNIT	PKG QTY	STOCK NO.
5/16" X 2 3/4"	0.02 LBS	EA	1	430846

SNAPPER PIN SQUARE LOCKING

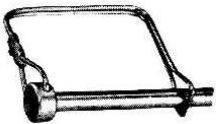

SIZE	WEIGHT	UNIT	PKG QTY	STOCK NO.
1/4" X 2"	0.065 LBS	EA	1	430845
5/16" X 2 3/4"	0.123 LBS	EA	1	430847
5/16" X 3 15/16"	0.114 LBS	EA	1	430850
3/8" X 3 7/16"	0.17 LBS	EA	1	430849
3/8" X 2 3/4"	0.138 LBS	EA	1	430848

WARNING

To prevent the possibility of serious bodily injury:
 * DO NOT EXCEED the working load limits

WEDGES



SAW WEDGE

SIZE	WIDTH	WEIGHT	UNIT	STOCK NO.
5 5/8"	3 1/8"	0.80 LBS	EA	475820
6 3/4"	2"	0.80 LBS	EA	475819
7"	3 1/2"	1.30 LBS	EA	475818

SETUP WEDGE TOOL



SIZE	LENGTH	WIDTH	WEIGHT	UNIT	STOCK NO.
1"	3"	1"	0.13 LBS	EA	902009
1 1/4"	5"	1 1/4"	0.31 LBS	EA	902010
1 1/4"	6"	1 1/4"	0.63 LBS	EA	902011

⚠ WARNING
To prevent the possibility of serious bodily injury: • DO NOT EXCEED the working load limits

STRIKING TOOLS



CLAW HAMMER

SIZE	DESCRIPTION	WEIGHT	UNIT	STOCK NO.
16 OZ	CLAW, WOOD HANDLE	1.50 LBS	EA	497230
16 OZ	CLAW, FIBERGLASS HANDLE	1.77 LBS	EA	497236
16 OZ	RIP, WOOD HANDLE	1.00 LBS	EA	497232
16 OZ	EASTWING, WOOD HANDLE	1.00 LBS	EA	497235
24 OZ	CLAW, FIBERGLASS HANDLE	2.25 LBS	EA	497238
16 OZ	FRAMING, WOOD HANDLE	1.50 LBS	EA	497240
24 OZ	FRAMING, WOOD HANDLE	2.29 LBS	EA	497239



HAND DRILL HAMMER

SIZE	WEIGHT	UNIT	STOCK NO.
2 LB	2.38 LBS	EA	497285
3 LB	3.50 LBS	EA	497286
4 LBS	4.42 LBS	EA	497287



DEADBLOW HAMMER

SIZE	WEIGHT	UNIT	STOCK NO.
32 OZ	2.35 LBS	EA	497272



PICK HOOK HAMMER

SIZE	DESCRIPTION	WEIGHT	UNIT	STOCK NO.
16 OZ	FIBERGLASS HANDLE	1.50 LBS	EA	497290

WARNING

To prevent the possibility of serious bodily injury:
 • DO NOT EXCEED the working load limits

STRIKING TOOLS

SLEDGE HAMMER



SIZE	DESCRIPTION	WEIGHT	UNIT	STOCK NO.
2 LB	12" WOOD HANDLE	2.00 LBS	EA	497302
3 LB	14" WOOD HANDLE	3.40 LBS	EA	497303
4 LB	14" WOOD HANDLE	4.58 LBS	EA	497304
6 LB	32" WOOD HANDLE	7.00 LBS	EA	497306
8 LB	32" WOOD HANDLE	9.20 LBS	EA	497308
10 LB	32" WOOD HANDLE	11.90 LBS	EA	497310
12 LB	32" WOOD HANDLE	13.50 LBS	EA	497312
16 LB	32" WOOD HANDLE	17.50 LBS	EA	497316
20 LB	32" WOOD HANDLE	23.30 LBS	EA	497320

SLEDGE HAMMER (DOMESTIC)



SIZE	DESCRIPTION	WEIGHT	UNIT	STOCK NO.
2 LB	12" WOOD HANDLE	2.20 LBS	EA	497302D
3 LB	14" WOOD HANDLE	3.40 LBS	EA	497303D
4 LB	14" WOOD HANDLE	4.58 LBS	EA	497304D
6 LB	32" WOOD HANDLE	7.00 LBS	EA	497306D
8 LB	32" WOOD HANDLE	9.00 LBS	EA	497308D
10 LB	32" WOOD HANDLE	11.00 LBS	EA	497310D
12 LB	32" WOOD HANDLE	13.50 LBS	EA	497312D
16 LB	32" WOOD HANDLE	17.50 LBS	EA	497316D
20 LB	32" WOOD HANDLE	23.30 LBS	EA	497320D

WARNING

To prevent the possibility of serious bodily injury:
 • **DO NOT EXCEED** the working load limits

STRIKING TOOLS



WOOD SPLITTER MAUL

SIZE	WEIGHT	UNIT	STOCK NO.
6 LB	7.20 LBS	EA	497397
8 LB	9.30 LBS	EA	497398

WOOD HANDLE



SIZE	DESCRIPTION	WEIGHT	UNIT	STOCK NO.
12"	16 OZ CLAW HAMMER	0.40 LBS	EA	497905
12"	2# SLEDGE	0.50 LBS	EA	497912
12"	3# SLEDGE	0.50 LBS	EA	497912
12"	4# SLEDGE	0.50 LBS	EA	497912
16"	4# SLEDGE	0.50 LBS	EA	495910
16"	2# SLEDGE	1.00 LBS	EA	497916
16"	3# SLEDGE	1.00 LBS	EA	497916
16"	4# SLEDGE	1.00 LBS	EA	497916
20"	4 LB SLEDGE	1.20 LBS	EA	497920
36"	16# SLEDGE	1.50 LBS	EA	495916
36"	16# SLEDGE YELLOW SAFETY GRIP	1.50 LBS	EA	495916YG
36"	20# SLEDGE	1.50 LBS	EA	495920



MACHETTE

SIZE	WEIGHT	UNIT	STOCK NO.
18"	1.19 LBS	EA	497610

WARNING

To prevent the possibility of serious bodily injury:
 * DO NOT EXCEED the working load limits

STRIKING TOOLS



BALL PEIN HAMMER



SIZE	DESCRIPTION	WEIGHT	UNIT	STOCK NO.
12 OZ	WOOD HANDLE	1.25 LBS	EA	497200
16 OZ	WOOD HANDLE	1.60 LBS	EA	497201
16 OZ	FIBERGLASS HANDLE	1.95 LBS	EA	497201FG
24 OZ	WOOD HANDLE	2.00 LBS	EA	497202
24 OZ	BRASS, FIBERGLASS HANDLE	2.50 LBS	EA	497202B
24 OZ	FIBERGLASS HANDLE	2.50 LBS	EA	497202FG
32 OZ	WOOD HANDLE	2.64 LBS	EA	497203
32 OZ	FIBERGLASS HANDLE	2.95 LBS	EA	497203FG
40 OZ	WOOD HANDLE	3.10 LBS	EA	497205
48 OZ	WOOD HANDLE	3.29 LBS	EA	497204
48 OZ	FIBERGLASS HANDLE	3.50 LBS	EA	497204FG



CHIPPING-WELDING HAMMER

SIZE	WEIGHT	UNIT	STOCK NO.
8 OZ	1.10 LBS	EA	497220



BRICK HAMMER

SIZE	DESCRIPTION	WEIGHT	UNIT	STOCK NO.
16 OZ	WOOD HANDLE	1.00 LBS	EA	497210
18 OZ	METAL HANDLE	1.30 LBS	EA	497212
24 OZ	METAL HANDLE	1.50 LBS	EA	497213



CROSS PEIN HAMMER

SIZE	DESCRIPTION	WEIGHT	UNIT	STOCK NO.
2 1/2 LBS	WOOD HANDLE	2.70 LBS	EA	497261
3 LBS	WOOD HANDLE	3.30 LBS	EA	497262
4 LBS	WOOD HANDLE	4.58 LBS	EA	497265

WARNING

To prevent the possibility of serious bodily injury:
 * DO NOT EXCEED the working load limits

HAND TOOLS

BOLT CUTTER



SIZE	WEIGHT	UNIT	STOCK NO.
14"	2.40 LBS	EA	475072
18"	4.20 LBS	EA	475073
24"	6.40 LBS	EA	475070
36"	7.90 LBS	EA	475071



CALIPER

SIZE	DESCRIPTION	WEIGHT	UNIT	STOCK NO.
N/A	PLASTIC 2 PC SET	0.20 LBS	SET	472511
6"	STAINLESS, VERNIER	0.70 LBS	EA	472505
N/A	DIAL	0.63 LBS	EA	472507
4"	BRASS	0.12 LBS	EA	472515



CHALKLINE

SIZE	WEIGHT	UNIT	STOCK NO.
100'	0.57 LBS	EA	475099

"C" CLAMP – LIGHT DUTY



SIZE	DESCRIPTION	WEIGHT	UNIT	STOCK NO.
3"	3" JAW, THROAT DEPTH 1 1/2"	1.29 LBS	EA	475088
4"	4" JAW, THROAT DEPTH 2 1/4"	1.77 LBS	EA	475090
6"	6" JAW, THROAT DEPTH 2 3/4"	3.50 LBS	EA	475093
8"	8" JAW, THROAT DEPTH 3 3/8"	5.00 LBS	EA	475094
10"	10" JAW, THROAT DEPTH 4 3/4"	6.16 LBS	EA	475096
12"	12" JAW, THROAT DEPTH 5 1/8"	8.83 LBS	EA	475097

WARNING

To prevent the possibility of serious bodily injury:
 * DO NOT EXCEED the working load limits

HAND TOOLS

"C" CLAMP – LOCKING



SIZE	DESCRIPTION	WEIGHT	UNIT	STOCK NO.
11"	JAW OPENING 3 1/8"	1.66 LBS	EA	475085
18"	JAW OPENING 8 3/8"	2.79 LBS	EA	475086

EXTENSION CORD



SIZE	DESCRIPTION	WEIGHT	UNIT	STOCK NO.
25'	12/3 X 25' TRI OUTLET	3.90 LBS	EA	474342
25'	16/3 X 25'	2.10 LBS	EA	474320
50'	10/3 X 50'	13.00 LBS	EA	474345
50'	12/3 X 50' TRI OUTLET	7.50 LBS	EA	474343
50'	16/3 X 50'	3.75 LBS	EA	474323
100'	16/3 X 100'	7.50 LBS	EA	474326
2'	TRI TAP (3 OUTLET)	1.00 LBS	EA	474340

PIPE CUTTER



SIZE	DESCRIPTION	WEIGHT	UNIT	STOCK NO.
1/8" - 1 1/8"	TUBE CUTTER W/REAMER	0.58 LBS	EA	475101
1/8" - 2"	TUBE CUTTER HEAVY DUTY	2.30 LBS	EA	475102

ELECTRICAL CRIMPER



SIZE	DESCRIPTION	WEIGHT	UNIT	STOCK NO.
9 1/2"	ELECTRICAL 8 WAY	0.69 LBS	EA	475149

WARNING

To prevent the possibility of serious bodily injury:
 • DO NOT EXCEED the working load limits

HAND TOOLS



ELECTRIAL TERMINAL SET

SIZE	DESCRIPTION	WEIGHT	UNIT	STOCK NO.
175 PCS	ELEC. TERMINAL SET	0.45 LBS	EA	475151
500 PCS	ELEC. TERMINAL SET	1.00 LBS	EA	475152

MILL BASTARD FILE

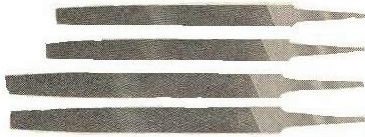

SIZE	WEIGHT	UNIT	STOCK NO.
6"	0.27 LBS	EA	475970
8"	0.34 LBS	EA	475971
10"	0.45 LBS	EA	475972
12"	0.56 LBS	EA	475973



PNEUMATIC GRINDER



SIZE	DESCRIPTION	WEIGHT	UNIT	STOCK NO.
1/4"	JET® AIR DIE GRINDER	1.84 LBS	EA	474530
1/4"	JET® ANGLE AIR DIE GRINDER	1.40 LBS	EA	474531



HANDTRUCK

SIZE	DESCRIPTION	WEIGHT	UNIT	STOCK NO.
600 LBS	8" TIRES	22.00 LBS	EA	475160
800 LBS	14" TIRES	36.50 LBS	EA	475159

⚠ WARNING

To prevent the possibility of serious bodily injury:

- **DO NOT EXCEED** the working load limits

HAND TOOLS

HYDRAULIC JACK



SIZE	DESCRIPTION	WEIGHT	UNIT	STOCK NO.
2 TON	BOTTLE	5.83 LBS	EA	475169
2 TON	BOTTLE, JET®	5.85 LBS	EA	475212J
3 TON	BOTTLE	8.75 LBS	EA	475170
3 TON	BOTTLE, JET®	6.00 LBS	EA	475213J
4 TON	BOTTLE	9.12 LBS	EA	475171
5 TON	BOTTLE, JET®	9.00 LBS	EA	475215J
6 TON	BOTTLE	14.60 LBS	EA	475172
8 TON	BOTTLE	17.75 LBS	EA	475173
8 TON	BOTTLE, JET®	13.00 LBS	EA	475218J
10 TON	BOTTLE	18.00 LBS	EA	475175
12 TON	BOTTLE	18.50 LBS	EA	475177
12 TON	BOTTLE, LOW PROFILE JET®	15.00 LBS	EA	475221J
12 TON	BOTTLE, JET®	18.00 LBS	EA	475222J
20 TON	BOTTLE	31.00 LBS	EA	475179
22 TON	BOTTLE LOW PROFILE JET®	23.00 LBS	EA	475231J
22 TON	BOTTLE, JET®	28.00 LBS	EA	475232J

UTILITY KNIVES

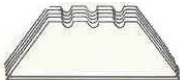
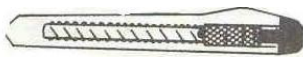

SIZE	DESCRIPTION	WEIGHT	UNIT	STOCK NO.
N/A	HD, SAFETY, YELLOW W/5BLADES	0.79 LBS	EA	475246
5"	SNAP OFF BLADE, SMALL	0.06 LBS	EA	475247
5 1/2"	WITH 2 BLADES	0.26 LBS	EA	475250
N/A	REPLACEMENT BLADES FOR 475250 PKG OF 10	0.09 LBS	EA	475251



LETTER & NUMBER KIT

SIZE	DESCRIPTION	WEIGHT	UNIT	STOCK NO.
1/4"	NUMBER STAMP KIT	0.75 LBS	SET	475352
1/4"	LETTER STAMP KIT	1.15 LBS	SET	475353

LIGHT



SIZE	DESCRIPTION	WEIGHT	UNIT	STOCK NO.
25'	TROUBLE LIGHT, 18-2,12V	0.90 LBS	EA	475255
8"	CLAMP LIGHT	0.90 LBS	EA	475256

WARNING

To prevent the possibility of serious bodily injury:
 * DO NOT EXCEED the working load limits

HAND TOOLS

MAGNETIC PICK-UP TOOL



SIZE	DESCRIPTION	WEIGHT	UNIT	STOCK NO.
18"	MAGNETIC PICK UP	0.20 LBS	EA	475300
25"	TELESCOPING 3 LB CAP.	0.13 LBS	EA	475302
21"	TELESCOPING 1 LB CAP.	0.13 LBS	EA	475303

MALLET



SIZE	DESCRIPTION	WEIGHT	UNIT	STOCK NO.
4 PC	RUBBER	4.75 LBS	EA	475305
N/A	DEAD BLOW	1.80 LBS	EA	475304

PADLOCK



SIZE	DESCRIPTION	WEIGHT	UNIT	STOCK NO.
1 1/2"	LAMINATED	0.50 LBS	EA	475359
2"	LAMINATED	0.86 LBS	EA	475360

PLIERS



SIZE	DESCRIPTION	WEIGHT	UNIT	STOCK NO.
4 3/4"	BENT NEEDLE NOSE	0.21 LBS	EA	475421
4 3/4"	DIAGONAL CUTTER	0.21 LBS	EA	475420
10 1/2"	FENCING PLIERS	1.71 LBS	EA	475431
10"	LOCKING VICE GRIP	1.32 LBS	EA	475413

PLIERS



SIZE	DESCRIPTION	WEIGHT	KLEIN PART NO	UNIT	STOCK NO.
9 1/4"	PLIERS SIDE CUT, HIGH LEVERAGE	1.15 LBS	D2000-9NE	EA	475365
9 1/4"	PLIERS SIDE CUT, HIGH LEVERAGE	1.40 LBS	D213-9NE	EA	475394
9 9/32"	SIDE CUTTING FOR REBAR WORK	1.15 LBS	D213-9ST	EA	475395
10"	WATER PUMP PLIERS	1.05 LBS	D502-10	EA	475396
8"	DIAGONAL CUT, PLASTIC-DIPPED HANDLES	0.95 LBS	D228-8	EA	475398
8 5/16"	HD, LONG NOSE, SIDE CUT	0.85 LBS	D203-8N	EA	475399
7 5/16"	PLIERS, SIDE CUT NE TYPE	0.60 LBS	D201-7NE	EA	475407
8"	DIAGONAL CUT, ANGLED HEAD	1.00 LBS	D248-8	EA	475409
9"	DIAGONAL CUT, ANGLED HEAD, FOR REBAR WORK	1.00 LBS	D248-9ST	EA	475412
8 3/4"	SIDE CUTTING FOR REBAR WORK	0.63 LBS	D2000-7CST	EA	475419
8 3/4"	SIDE CUTTING REBAR	0.60 LBS	D201-7CST	EA	475408
9 9/32"	SIDE CUTTING FOR REBAR WORK, HEAVY DUTY	2.45 LBS	D2000-9ST	EA	475428

WARNING

To prevent the possibility of serious bodily injury:
 • DO NOT EXCEED the working load limits

HAND TOOLS



PLIERS (SETS)

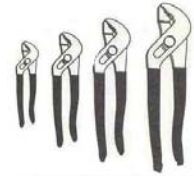

SIZE	DESCRIPTION	WEIGHT	UNIT	STOCK NO.
6"-8"-10"	SLIP JOINT 3 PC SET	2.04 LBS	SET	475425
5 PC SET	SNAP RING, SLIP RING STRAIGHT & OFFSET TIP	1.25 LBS	SET	475427
6"-8"-10"-12"	WATER PUMP PLIERS 4 PC SET	3.40 LBS	EA	475414



HAND ROTARY PUMP - BARREL

SIZE	WEIGHT	UNIT	STOCK NO.
T	11.00 LBS	EA	475455

BACK-OUT PUNCH

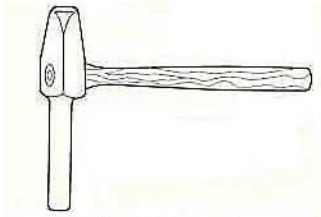

SIZE	WEIGHT	UNIT	STOCK NO.
1/2"	3.20 LBS	EA	475441
5/8"	3.30 LBS	EA	475442
3/4"	3.30 LBS	EA	475445
7/8"	3.30 LBS	EA	475443
1"	3.80 LBS	EA	475444



ROLL PIN

SIZE	DESCRIPTION	WEIGHT	UNIT	STOCK NO.
MULTI	315 PC ROLL PIN ASSORTMENT	0.80 LBS	SET	470025

WARNING

To prevent the possibility of serious bodily injury:
 • DO NOT EXCEED the working load limits

HAND TOOLS

RIVET TOOL

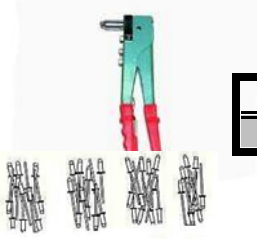

SIZE	DESCRIPTION	WEIGHT	UNIT	STOCK NO.
60 PC	HAND RIVETER	1.75 LBS	SET	475499

SAW



SIZE	DESCRIPTION	WEIGHT	UNIT	STOCK NO.
30"	BOW SAW	1.00 LBS	EA	475503
36"	BOW SAW	1.10 LBS	EA	475506
N/A	COMPACT UTILITY HACKSAW	0.30 LBS	EA	475509
12"	HACKSAW FRAME	1.64 LBS	EA	475518

SAW BLADES



SIZE	DESCRIPTION	WEIGHT	UNIT	STOCK NO.
21"	BOW SAW	0.10 LBS	EA	475501
24"	BOW SAW	0.10 LBS	EA	475502
30"	BOW SAW	0.10 LBS	EA	475504
36	BOW SAW	0.10 LBS	EA	475507
12"	HACKSAW 24T	0.04 LBS	EA	475517

WARNING

To prevent the possibility of serious bodily injury:
 • DO NOT EXCEED the working load limits

HAND TOOLS

SCRAPER



SIZE	DESCRIPTION	WEIGHT	UNIT	STOCK NO.
2"	PLASTIC HANDLE	0.15 LBS	EA	475530
3"	PLASTIC HANDLE	0.18 LBS	EA	475531
4"	PLASTIC HANDLE	0.20 LBS	EA	475532
N/A	GASKET SCRAPER	0.20 LBS	EA	475539

SCREWDRIVER



SIZE	DESCRIPTION	WEIGHT	UNIT	STOCK NO.
2 PC	#1 PHILLIPS AND #1 SLOTTED	0.26 LBS	SET	475552
6-WAY	6 WAY PHILLIPS & SLOTTED	0.26 LBS	EA	475556
41 PC	BIT SOCKET SET, 3 WAY	1.70 LBS	SET	475559
22 PC	HIGH VISIBILITY	4.80 LBS	SET	475561
8 PC	MECHANIC, ORANGE	1.65 LBS	SET	475557
14 PC	NUTDRIVER SET	1.79 LBS	SET	475553
12 PC	SLOTTED	1.80 LBS	SET	475560
7 PC	SCREWDRIVER SET W/RACK	0.60 LBS	SET	475554
6 PC	TORQUE WITH HOLDER	1.00 LBS	SET	475551
30 PC	BIT & HANDLE, BULLDOG	0.92 LBS	SET	475564

SNAP RING & PIN ASSORTMENT



SIZE	DESCRIPTION	WEIGHT	UNIT	STOCK NO.
300 PCS	SNAP RING	1.10 LBS	SET	470005
300PCS	E PIN	1.10 LBS	SET	475010
315 PCS	ROLL PIN	0.80 LBS	SET	475025
1000 PCS	COTTER PIN	1.10 LBS	SET	475030
150 PCS	HAIR PIN	1.10 LBS	SET	475040

WARNING

To prevent the possibility of serious bodily injury:
 • **DO NOT EXCEED** the working load limits

HAND TOOLS

SOCKET SET



SIZE	DESCRIPTION	WEIGHT	UNIT	STOCK NO.
1/4"	22 PC CHROME, SAE	2.25 LBS	SET	480010
1/4"	9 PC CHROME, SAE	2.25 LBS	SET	480050
1/4"	9 PC CHROME, METRIC	2.04 LBS	SET	480051
3/8"	21 PC CHROME, SAE	5.00 LBS	SET	480012
3/8"	21 PC CHROME, METRIC	4.40 LBS	SET	480013
3/8"	9 PC DEEP CHROME, SAE	2.25 LBS	SET	480052
3/8"	9 PC CHROME, METRIC	2.30 LBS	SET	480053
3/8"	9 PC SHALLOW, IMPACT, SAE	1.16 LBS	SET	480070
3/8"	9 PC DEEP, IMPACT, SAE	2.55 LBS	SET	480072
3/8"	9 PC DEEP, IMPACT, METRIC	2.15 LBS	SET	480073
1/2"	17 PC CHROME, SAE	8.33 LBS	SET	480014
1/2"	17 PC CHROME, METRIC	8.30 LBS	SET	480015
1/2"	9 PC CHROME, SAE	3.75 LBS	SET	480054
1/2"	9 PC CHROME, METRIC	3.38 LBS	SET	480055
1/2"	15 PC DEEP IMPACT, SAE	5.00 LBS	SET	480076
1/2"	15 PC DEEP IMPACT, METRIC	9.00 LBS	SET	480077
1/2"	11 PC IMPACT, SAE	3.05 LBS	SET	480084
1/2"	11 PC IMPACT, METRIC	3.05 LBS	SET	480085
3/4"	21 PC CHROME, SAE	33.00 LBS	SET	480020
3/4"	21 PC CHROME, METRIC	33.00 LBS	SET	480021
3/4"	9 PC DEEP IMPACT, SAE	12.60 LBS	SET	480078
3/4"	9 PC SHALLOW, IMPACT, SAE	8.50 LBS	SET	480086
3/4"	9 PC SHALLOW, IMPACT, METRIC	8.50 LBS	SET	480087
1"	21 PC CHROME, SAE	87.00 LBS	SET	480024
1/4"-3/8"-1/2" DR	60 PC, SAE	16.00 LBS	SET	480016
1/4"-3/8"-1/2" DR	60 PC, METRIC	15.00 LBS	SET	480017

RATCHET HANDLE



SIZE	DESCRIPTION	WEIGHT	UNIT	STOCK NO.
1/4"	RATCHET 6"	0.43 LBS	EA	480200
3/8"	RATCHET 8"	0.92 LBS	EA	480201
1/2"	RATCHET 10"	1.31 LBS	EA	480202
1/2"	QUICK RELEASE 10"	1.50 LBS	EA	480208
3/4"	RATCHET 18"	4.20 LBS	EA	480203
3/4"	BREAKER FLEX 24"	4.25 LBS	EA	480235
1"	RATCHET 26"	8.20 LBS	EA	480204

WARNING

To prevent the possibility of serious bodily injury:
 • DO NOT EXCEED the working load limits

HAND TOOLS



IMPACT SOCKET STANDARD SAE (GREY PNEUMATIC LIFETIME WARRANTY)



SIZE	DRIVE	WEIGHT	UNIT	STOCK NO.	SIZE	DRIVE	WEIGHT	UNIT	STOCK NO.
3/8"	1/2"	0.10 LBS	EA	4812012R	1 5/16"	3/4"	0.90 LBS	EA	4813042R
7/16"	1/2"	0.10 LBS	EA	4812014R	1 3/8"	3/4"	1.00 LBS	EA	4813044R
1/2"	1/2"	0.10 LBS	EA	4812016R	1 7/16"	3/4"	0.90 LBS	EA	4813046R
9/16"	1/2"	0.20 LBS	EA	4812018R	1 1/2"	3/4"	1.00 LBS	EA	4813048R
5/8"	1/2"	0.20 LBS	EA	4812020R	1 9/16"	3/4"	1.20 LBS	EA	4813050R
11/16"	1/2"	0.20 LBS	EA	4812022R	1 5/8"	3/4"	1.30 LBS	EA	4813052R
3/4"	1/2"	0.20 LBS	EA	4812024R	1 11/16"	3/4"	1.60 LBS	EA	4813054R
13/16"	1/2"	0.30 LBS	EA	4812026R	1 3/4"	3/4"	1.60 LBS	EA	4813056R
7/8"	1/2"	0.30 LBS	EA	4812028R	1 13/16"	3/4"	1.80 LBS	EA	4813058R
15/16"	1/2"	0.30 LBS	EA	4812030R	1 7/8"	3/4"	1.80 LBS	EA	4813060R
1"	1/2"	0.40 LBS	EA	4812032R	1 15/16"	3/4"	2.00 LBS	EA	4813062R
1 1/16"	1/2"	0.50 LBS	EA	4812034R	2"	3/4"	2.30 LBS	EA	4813064R
1 1/8"	1/2"	0.50 LBS	EA	4812036R	2 1/16"	3/4"	1.10 LBS	EA	4813066R
1 3/16"	1/2"	0.50 LBS	EA	4812038R	2 1/4"	3/4"	1.10 LBS	EA	4813072R
1 1/4"	1/2"	0.50 LBS	EA	4812040R	2 5/16"	3/4"	1.10 LBS	EA	4813074R
1 5/16"	1/2"	0.50 LBS	EA	4812042R	3/4"	1"	1.10 LBS	EA	4814024R
1 3/8"	1/2"	0.50 LBS	EA	4812044R	13/16"	1"	1.10 LBS	EA	4814026R
1 7/16"	1/2"	0.50 LBS	EA	4812046R	7/8"	1"	1.80 LBS	EA	4814028R
1 1/2"	1/2"	0.60 LBS	EA	4812048R	1"	1"	1.10 LBS	EA	4814032R
7/8"	3/4"	0.60 LBS	EA	4813028R	1 1/16"	1"	1.10 LBS	EA	4814034R
15/16"	3/4"	0.60 LBS	EA	4813030R	1 1/8"	1"	1.10 LBS	EA	4814036R
1"	3/4"	0.60 LBS	EA	4813032R	1 1/4"	1"	1.30 LBS	EA	4814040R
1 1/16"	3/4"	0.60 LBS	EA	4813034R	1 7/16"	1"	1.40 LBS	EA	4814046R
1 1/8"	3/4"	0.70 LBS	EA	4813036R	2"	1"	2.50 LBS	EA	4814064R
1 3/16"	3/4"	0.80 LBS	EA	4813038R	2 1/2"	1"	7.70 LBS	EA	4814080R
1 1/4"	3/4"	0.70 LBS	EA	4813040R	3"	1"	7.70 LBS	EA	4814096R

IMPACT SOCKET STANDARD METRIC (GREY PNEUMATIC LIFETIME WARRANTY)



SIZE	DRIVE	WEIGHT	UNIT	STOCK NO.	SIZE	DRIVE	WEIGHT	UNIT	STOCK NO.
10MM	1/2"	0.20 LBS	EA	4812010M	19MM	1/2"	0.20 LBS	EA	4812019M
11MM	1/2"	0.50 LBS	EA	4812011M	20MM	1/2"	0.30 LBS	EA	4812020M
12MM	1/2"	0.20 LBS	EA	4812012M	21MM	1/2"	0.30 LBS	EA	4812021M
13MM	1/2"	0.20 LBS	EA	4812013M	22MM	1/2"	0.30 LBS	EA	4812022M
14MM	1/2"	0.20 LBS	EA	4812014M	23MM	1/2"	0.30 LBS	EA	4812023M
15MM	1/2"	0.20 LBS	EA	4812015M	24MM	1/2"	0.40 LBS	EA	4812024M
16MM	1/2"	0.20 LBS	EA	4812016M	26MM	1/2"	0.40 LBS	EA	4812026M
17MM	1/2"	0.20 LBS	EA	4812017M	27MM	1/2"	0.50 LBS	EA	4812027M
18MM	1/2"	0.20 LBS	EA	4812018M					

CONTACT YOUR SALES REPRESENTATIVE FOR OTHER SIZES & AVAILABILITY

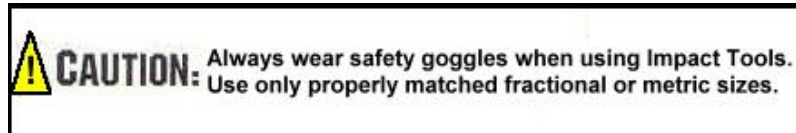

HAND TOOLS



IMPACT SOCKET DEEP SAE (GREY PNEUMATIC LIFETIME WARRANTY)



SIZE	DRIVE	WEIGHT	UNIT	STOCK NO.	SIZE	DRIVE	WEIGHT	UNIT	STOCK NO.
3/8"	1/2"	0.30 LBS	EA	4812012D	1 5/16"	3/4"	1.50 LBS	EA	4813042D
7/16"	1/2"	0.30 LBS	EA	4812014D	1 3/8"	3/4"	1.40 LBS	EA	4813044D
1/2"	1/2"	0.30 LBS	EA	4812016D	1 7/16"	3/4"	1.40 LBS	EA	4813046D
9/16"	1/2"	0.40 LBS	EA	4812018D	1 1/2"	3/4"	1.70 LBS	EA	4813048D
5/8"	1/2"	0.40 LBS	EA	4812020D	1 9/16"	3/4"	1.70 LBS	EA	4813050D
11/16"	1/2"	0.50 LBS	EA	4812022D	1 5/8"	3/4"	1.80 LBS	EA	4813052D
3/4"	1/2"	0.50 LBS	EA	4812024D	1 11/16"	3/4"	2.20 LBS	EA	4813054D
13/16"	1/2"	0.60 LBS	EA	4812026D	1 3/4"	3/4"	2.30 LBS	EA	4813056D
7/8"	1/2"	0.70 LBS	EA	4812028D	1 13/16"	3/4"	2.40 LBS	EA	4813058D
15/16"	3/4"	0.90 LBS	EA	4813030D	1 7/8"	3/4"	2.20 LBS	EA	4813060D
1"	3/4"	1.00 LBS	EA	4813032D	1 15/16"	3/4"	2.30 LBS	EA	4813062D
1 1/6"	3/4"	0.90 LBS	EA	4813034D	2"	3/4"	2.80 LBS	EA	4813064D
1 1/8"	3/4"	1.00 LBS	EA	4813036D	2 1/2"	1"	5.80 LBS	EA	4814080D
1 3/16"	3/4"	1.20 LBS	EA	4813038D	2 3/4"	1"	6.00 LBS	EA	4814088D
1 1/4"	3/4"	1.10 LBS	EA	4813040D					

IMPACT SOCKET DEEP METRIC (GREY PNEUMATIC LIFETIME WARRANTY)



SIZE	DRIVE	WEIGHT	UNIT	STOCK NO.	SIZE	DRIVE	WEIGHT	UNIT	STOCK NO.
10MM	1/2"	0.30 LBS	EA	4812010MD	19MM	1/2"	0.50 LBS	EA	4812019MD
11MM	1/2"	0.30 LBS	EA	4812011MD	20MM	1/2"	0.60 LBS	EA	4812020MD
12MM	1/2"	0.30 LBS	EA	4812012MD	21MM	1/2"	0.50 LBS	EA	4812021MD
13MM	1/2"	0.40 LBS	EA	4812013MD	22MM	1/2"	0.60 LBS	EA	4812022MD
14MM	1/2"	0.40 LBS	EA	4812014MD	23MM	1/2"	0.60 LBS	EA	4812023MD
15MM	1/2"	0.40 LBS	EA	4812015MD	24MM	1/2"	0.70 LBS	EA	4812024MD
16MM	1/2"	0.40 LBS	EA	4812016MD	26MM	1/2"	0.50 LBS	EA	4812026MD
17MM	1/2"	0.40 LBS	EA	4812017MD	27MM	1/2"	0.80 LBS	EA	4812027MD
18MM	1/2"	0.40 LBS	EA	4812018MD					

CONTACT YOUR SALES REPRESENTATIVE FOR OTHER SIZES & AVAILABILITY

⚠ CAUTION: Always wear safety goggles when using Impact Tools.
Use only properly matched fractional or metric sizes.

HAND TOOLS



IMPACT SOCKET UNIVERSAL STANDARD-SAE (GREY PNEUMATIC LIFETIME WARRANTY)

SIZE	DRIVE	WEIGHT	UNIT	STOCK NO.	SIZE	DRIVE	WEIGHT	UNIT	STOCK NO.
7/16"	1/2"	0.40 LBS	EA	4812014U	11/16"	1/2"	0.50 LBS	EA	4812022U
1/2"	1/2"	0.40 LBS	EA	4812016U	3/4"	1/2"	0.50 LBS	EA	4812024U
9/16"	1/2"	0.40 LBS	EA	4812018U	13/16"	1/2"	0.60 LBS	EA	4812026U
5/8"	1/2"	0.40 LBS	EA	4812020U					



IMPACT SOCKET UNIVERSAL STANDARD-METRIC (GREY PNEUMATIC LIFETIME WARRANTY)

SIZE	DRIVE	WEIGHT	UNIT	STOCK NO.	SIZE	DRIVE	WEIGHT	UNIT	STOCK NO.
11MM	1/2"	0.40 LBS	EA	4812011UM	15MM	1/2"	0.40 LBS	EA	4812015UM
12MM	1/2"	0.40 LBS	EA	4812012UM	17MM	1/2"	0.50 LBS	EA	4812017UM
13MM	1/2"	0.40 LBS	EA	4812013UM	18MM	1/2"	0.50 LBS	EA	4812018UM
14MM	1/2"	0.60 LBS	EA	4812014UM	19MM	1/2"	0.60 LBS	EA	4812019UM

IMPACT SOCKET UNIVERSAL DEEP-SAE (GREY PNEUMATIC LIFETIME WARRANTY)



SIZE	DRIVE	WEIGHT	UNIT	STOCK NO.
7/16"	1/2"	0.40 LBS	EA	4812014UD
1/2"	1/2"	0.50 LBS	EA	4812016UD
9/16"	1/2"	0.50 LBS	EA	4812018UD
5/8"	1/2"	0.50 LBS	EA	4812020UD
11/16"	1/2"	0.70 LBS	EA	4812022UD
3/4"	1/2"	0.60 LBS	EA	4812024UD
13/16"	1/2"	0.70 LBS	EA	4812026UD

IMPACT SOCKET UNIVERSAL DEEP-METRIC (GREY PNEUMATIC LIFETIME WARRANTY)



SIZE	DRIVE	WEIGHT	UNIT	STOCK NO.
11MM	1/2"	0.40 LBS	EA	4812011UMD
12MM	1/2"	0.50 LBS	EA	4812012UMD
13MM	1/2"	0.50 LBS	EA	4812013UMD
14MM	1/2"	0.50 LBS	EA	4812014UMD
15MM	1/2"	0.50 LBS	EA	4812015UMD
17MM	1/2"	0.70 LBS	EA	4812017UMD
18MM	1/2"	0.60 LBS	EA	4812018UMD
19MM	1/2"	0.60 LBS	EA	4812019UMD
21MM	1/2"	0.60 LBS	EA	4812021UMD

CONTACT YOUR SALES REPRESENTATIVE FOR OTHER SIZES & AVAILABILITY



CAUTION: Always wear safety goggles when using Impact Tools.
Use only properly matched fractional or metric sizes.

HAND TOOLS



IMPACT SOCKET FLIP (GREY PNEUMATIC LIFETIME WARRANTY)

SIZE	DRIVE	DESCRIPTION	WEIGHT	UNIT	STOCK NO.
3/4" & 13/16"	1/2"	THIN WALL	0.30 LBS	EA	4812146DT
3/4" & 13/16"	1/2"	EXTRA THIN WALL	0.50 LBS	EA	4812346D
19MM & 21MM	1/2"	THIN WALL	0.30 LBS	EA	4812192DT
19MM & 21MM	1/2"	EXTRA THIN WALL	0.50 LBS	EA	4812392D



IMPACT RATCHET EXTENSION (GREY PNEUMATIC LIFETIME WARRANTY)

DRIVE	LENGTH	WEIGHT	UNIT	STOCK NO.
1/2"	3"	0.30 LBS	EA	4812243E
1/2"	5"	0.50 LBS	EA	4812245E
1/2"	10"	1.00 LBS	EA	4812210E
3/4"	7"	2.00 LBS	EA	4813007EB



ADAPTER IMPACT (GREY PNEUMATIC LIFETIME WARRANTY)

SIZE	DESCRIPTION	WEIGHT	UNIT	STOCK NO.
1/2" X 3/8"	1/2" FEMALE, 3/8" MALE	0.01 LBS	EA	4812228A
1/2" X 1/2"	1/2" FEMALE, 1/2" MALE	0.05 LBS	EA	4812229UJ
1/2" X 3/4"	1/2" FEMALE, 3/4" MALE	0.04 LBS	EA	4812238A
3/4" X 1/2"	3/4" FEMALE, 1/2" MALE	0.07 LBS	EA	4813008A
3/4" X 3/4"	3/4" FEMALE, 3/4" MALE	1.30 LBS	EA	4813006UJ
3/4" X 1"	3/4" FEMALE, 1" MALE	0.09 LBS	EA	4813009A
1" X 3/4"	1" FEMALE, 3/4" MALE	1.30 LBS	EA	4814008A

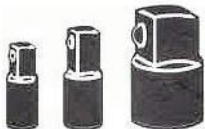

IMPACT ADAPTER SET

DESCRIPTION	WEIGHT	UNIT	STOCK NO.
3 PC SET 1/4", 3/8", 1/2"	0.45 LBS	EA	480240

CONTACT YOUR SALES REPRESENTATIVE FOR OTHER SIZES & AVAILABILITY

CAUTION: Always wear safety goggles when using Impact Tools.
Use only properly matched fractional or metric sizes.

HAND TOOLS



TAPE MEASURE

SIZE	DESCRIPTION	WEIGHT	UNIT	STOCK NO.
1/2" X 10'	TAPE MEASURE	0.61 LBS	EA	472010
1/2" X 12'	TAPE MEASURE	0.75 LBS	EA	472020
1/2" X 50'	TAPE MEASURE	1.00 LBS	EA	472030
1/2" X 100'	EXPOSED	1.10 LBS	EA	472040
1/2" X 200'	EXPOSED	1.10 LBS	EA	472055
1/2" X 300'	EXPOSED	0.95 LBS	EA	472060
3/4" X 12'	LUFKIN PRO 3000 SERIES	0.48 LBS	EA	472105D
3/4" X 12'	ENGINEERS	0.40 LBS	EA	472115D
3/4" X 16'	NEON	1.00 LBS	EA	472120
3/4" X 16'	QUICK READ	1.00 LBS	EA	472120D
3/4" X 16'	TAPE MEASURE	1.40 LBS	EA	472135
3/4" X 25'	TAPE MEASURE	1.40 LBS	EA	472140
3/4" X 25'	HIGH VISIBILITY	2.00 LBS	EA	472145
3/4" X 25'	POWER ORANGE	2.00 LBS	EA	472150D
3/4" X 25'	LUFKIN PRO 3000 SERIES	1.06 LBS	EA	472225D
3/4" X 30'	LUFKIN PRO 3000 SERIES	1.36 LBS	EA	472230D
1" X 25'	TAPE MEASURE	1.00 LBS	EA	472250
1" X 25'	EASY READ	1.00 LBS	EA	472255
1" X 30'	NEON	1.20 LBS	EA	472260
1" X 30'	TAPE MEASURE	1.20 LBS	EA	472270
5/8" X 48"	DOYLE LOG SCALE, WOOD	1.13 LBS	EA	472550D

TAPE MEASURE REPLACEMENT REFILL



SIZE	WEIGHT	UNIT	STOCK NO.
3/4" X 25'	0.50 LBS	EA	472335D
1" X 30'	0.90 LBS	EA	472345D

WARNING

To prevent the possibility of serious bodily injury:
 • **DO NOT EXCEED** the working load limits

HAND TOOLS



VICE

SIZE	DESCRIPTION	WEIGHT	UNIT	STOCK NO.
3	STEEL SWIVEL BENCH BLUE	13.67 LBS	EA	475803
4"	MULTI PURPOSE	46.30 LBS	EA	475800
4"	STEEL SWIVEL BENCH BLUE	28.00 LBS	EA	475804
5"	MULTI PURPOSE	75.00 LBS	EA	475801
5"	STEEL SWIVEL BENCH BLUE	33.00 LBS	EA	475805
6"	MULTI PURPOSE	83.79 LBS	EA	475802
6"	STEEL SWIVEL BENCH BLUE	60.00 LBS	EA	475806

WRENCH ADJUSTABLE



SIZE	WEIGHT	UNIT	STOCK NO.
4"	0.12 LBS	EA	485004
6"	0.31 LBS	EA	485006
8"	0.68 LBS	EA	485008
10"	1.18 LBS	EA	485010
10"	1.18 LBS	EA	485010D
12"	1.55 LBS	EA	485012
15"	3.12 LBS	EA	485015
18"	5.16 LBS	EA	485018
18"	5.16 LBS	EA	485018D
24"	10.33 LBS	EA	485024



WRENCH, ALLEN HEX SET

SIZE	DESCRIPTION	WEIGHT	UNIT	STOCK NO.
3/32" - 5/16"	SAE, 6PC	0.32 LBS	SET	485506
2.5MM - 8MM	METRIC, 6PC	0.32 LBS	SET	485506M
1/16" - 3/8" / 07MM - 08MM	SAE & METRIC, 30 PC	1.75 LBS	SET	485530
3/8" - 3/4"	JUMBO SAE, 6PC	0.58 LBS	SET	485556



⚠ WARNING

To prevent the possibility of serious bodily injury:
 • **DO NOT EXCEED** the working load limits

HAND TOOLS

COMBINATION WRENCH (BOX AND OPEN END)



SIZE	WEIGHT	UNIT	STOCK NO.	SIZE	WEIGHT	UNIT	STOCK NO.
1/4"	0.08 LBS	EA	485308	1 1/4"	2.12 LBS	EA	485338
5/16"	0.04 LBS	EA	485310	1 5/16"	2.20 LBS	EA	485342
3/8"	0.17 LBS	EA	485312	1 3/8"	2.08 LBS	EA	485344
7/16"	0.17 LBS	EA	485314	1 7/16"	2.20 LBS	EA	485346
1/2"	0.23 LBS	EA	485316	1 1/2"	2.21 LBS	EA	485348
9/16"	0.26 LBS	EA	485318	1 5/8"	2.25 LBS	EA	485352
5/8"	0.34 LBS	EA	485320	1 11/16"	2.75 LBS	EA	485354
11/16"	0.40 LBS	EA	485322	1 3/4"	2.30 LBS	EA	485356
3/4"	0.40 LBS	EA	485324	1 13/16"	4.35 LBS	EA	485358
13/16"	0.62 LBS	EA	485326	1 7/8"	2.35 LBS	EA	485360
7/8"	0.78 LBS	EA	485328	2"	2.50 LBS	EA	485364
15/16"	0.71 LBS	EA	485330	2 1/8"	2.75 LBS	EA	485368
1"	1.14 LBS	EA	485332	2 1/4"	2.90 LBS	EA	485372
1 1/16"	1.32 LBS	EA	485334	2 3/8"	3.10 LBS	EA	485376
1 1/8"	1.60 LBS	EA	485336	2 1/2"	10.35 LBS	EA	485380



COMBINATION WRENCH SET



SIZE	DESCRIPTION	WEIGHT	UNIT	STOCK NO.
3/8" - 1 1/4"	SAE ANGLE OPEN END, 14 PC SET	7.00 LBS	SET	485401
3/8" - 1 1/4"	SAE COMBO OPEN END 14 PC SET	9.50 LBS	SET	485414
8MM - 24MM	COMBO, STRAIGHT METRIC 14 PC SET	9.50 LBS	SET	485414M
1 5/8" - 1 7/8"	SAE COMBO, JUMBO 6 PC SET	22.00 LBS	SET	485455
27,30,32,33,34,35MM	COMB. JUMBO, METRIC, 6 PC SET	22.00 LBS	SET	485455M
1 3/8" - 2"	SAE COMBO, 6 PC SET	22.00 LBS	SET	485456
1 5/16" - 2"	SAE COMBO JUMBO, 10 PC SET	33.00 LBS	SET	485458
34,36,38,41,42,44,45,46,48,50MM	COMB, JUMBO, METRIC, 10 PC SET	33.00 LBS	SET	485458M

BOX RATCHET WRENCH



SIZE	DESCRIPTION	WEIGHT	UNIT	STOCK NO.
7/32" - 3/4"	SAE	1.46 LBS	SET	485795

WARNING

To prevent the possibility of serious bodily injury:
 • DO NOT EXCEED the working load limits

HAND TOOLS

PIPE WRENCH



SIZE	DESCRIPTION	WEIGHT	UNIT	STOCK NO.
8"	DROP FORGED	0.86 LBS	EA	485708
10"	DROP FORGED	1.83 LBS	EA	485710
14"	DROP FORGED	3.78 LBS	EA	485714
14"	ALUMINUM	2.30 LBS	EA	485714A
18"	DROP FORGED	5.00 LBS	EA	485718
18"	ALUMINUM	3.65 LBS	EA	485718A
24"	DROP FORGED	9.88 LBS	EA	485724
24"	ALUMINUM	6.00 LBS	EA	485724A
36"	DROP FORGED	12.00 LBS	EA	485736
36"	ALUMINUM	10.00 LBS	EA	485736A
48"	DROP FORGED	16.00 LBS	EA	485748

BROOM



SIZE	DESCRIPTION	WEIGHT	UNIT	STOCK NO.
16"	ASPHALT	4.00 LBS	EA	412216
24"	ARGO COMB SEMISOFT	2.80 LBS	EA	412220
24"	HORSEHAIR W/METAL TIP HANDLE	2.80 LBS	EA	412222
24"	ORANGE, W/METAL TIP HANDLE	3.20 LBS	EA	412223
24"	YELLOW W/WOOD THREADED HANDLE	2.60 LBS	EA	412224

⚠ WARNING

To prevent the possibility of serious bodily injury:
 • **DO NOT EXCEED** the working load limits

CRIMPING TOOLS & WIRE ROPE CUTTERS

CRIMPING & SWAGE TOOL

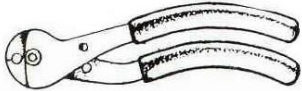
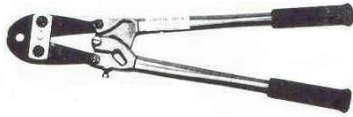

SIZE	DESCRIPTION	WEIGHT	UNIT	STOCK NO.
1/16"	HAND SWAGER	0.50 LBS	EA	907502
3/32"	HAND SWAGER	3.50 LBS	EA	907505
1/8"	HAND SWAGER	3.50 LBS	EA	907540
3/16"	HAND SWAGER	3.50 LBS	EA	907506
1/4"	HAND SWAGER	6.00 LBS	EA	907539
5/16"	HAND SWAGER	6.00 LBS	EA	907507
1/16"-3/16"	HAND SWAGER #1	6.50 LBS	EA	907501
1/16"-1/8"	CRIMPING TOOL #2 SWAGE IT	8.00 LBS	EA	907512

CABLE CUTTER



SIZE	DESCRIPTION	WEIGHT	UNIT	STOCK NO.
3/16"	CABLE CUTTER C-7 8"	1.00 LBS	EA	908501
3/8"	CABLE CUTTER C-12 19"	4.00 LBS	EA	908502
#1	IMPACT TYPE CUTTER, SMALL	8.00 LBS	EA	909001
#2	IMPACT TYPE CUTTER, MEDIUM	17.00 LBS	EA	909002
#3	IMPACT TYPE CUTTER, LARGE	28.00 LBS	EA	909003
1 1/8"	HYDRA-CUT, MODEL PP	34.00 LBS	EA	909019

REPLACEMENT BLADE (FOR IMPACT STYLE CUTTERS)



TOP BLADE



BOTTOM BLADE

SIZE	DESCRIPTON	WEIGHT	UNIT	FITS STOCK NO. ABOVE	STOCK NO.
#1 OR #2	CUTTER BLADE & PIN TOP	0.02 OZ	EA	909001 909002	909004
#3	CUTTER BLADE & PIN TOP	0.05 OZ	EA	909003	909005
#1	BOTTOM BLADE	0.04 OZ	EA	909001	909006
#2	BOTTOM BLADE	0.07 OZ	EA	909002	909007
#3	BOTTOM BLADE	0.10 OZ	EA	909003	909008
P4	BLADE, CUTTER P4	0.50 LBS	EA	909019	909047
P4	PIN, BLADE CUTTER, P-4	0.20 LBS	EA	909019	909048

WARNING

To prevent the possibility of serious bodily injury:
 * DO NOT EXCEED the working load limits

WIRE ROPE SLEEVES & STOPS

ALUMINUM BUTTON STOP SLEEVE



SIZE	UNIT	STOCK NO.
1/16"	EA	753002
3/32"	EA	753003
1/8"	EA	753004
5/32"	EA	753005
3/16"	EA	753006
7/32"	EA	753007
1/4"	EA	753008
3/8"	EA	753012

COPPER BUTTON STOP SLEEVE



SIZE	UNIT	STOCK NO.
1/32"	EA	754001
3/64"	EA	754001.1
1/16"	EA	754002
3/32"	EA	754003
1/8"	EA	754004
5/32"	EA	754005
3/16"	EA	754006
7/32"	EA	754007
1/4"	EA	754008

ALUMINUM DUPLEX SLEEVE



SIZE	UNIT	STOCK NO.
3/64"	EA	753200
1/32"	EA	753201
1/16"	EA	753202
3/32"	EA	753203
1/8"	EA	753204
5/32"	EA	753205
3/16"	EA	753206
7/32"	EA	753207
1/4"	EA	753208
5/16"	EA	753210
3/8"	EA	753212

COPPER DUPLEX SLEEVE



SIZE	UNIT	STOCK NO.
1/32"	EA	754501
1/16"	EA	754502
3/32"	EA	754503
1/8"	EA	754504
5/32"	EA	754505
3/16"	EA	754506
7/32"	EA	754507
1/4"	EA	754508
5/16"	EA	754510
3/8"	EA	754512

ZINC PLATED COPPER DUPLEX SLEEVE



SIZE	UNIT	STOCK NO.
5/16"	EA	754602
3/32"	EA	754603
1/8"	EA	754604
5/32"	EA	754605
3/16"	EA	754606
1/4"	EA	754608
1/2"	EA	754610
3/8"	EA	754612

 WARNING
To prevent the possibility of serious bodily injury: * DO NOT EXCEED the working load limits

DRILL BITS

WIRE GAUGE SIZE BITS #300 HIGH SPEED OXIDE



SIZE	UNIT	STOCK NO.	SIZE	UNIT	STOCK NO.	SIZE	UNIT	STOCK NO.	SIZE	UNIT	STOCK NO.
#0	PKG/12	452100	#16	PKG/12	452116	#32	PKG/12	452132	#48	PKG/12	452148
#1	PKG/12	452101	#17	PKG/12	452117	#33	PKG/12	452133	#49	PKG/12	452149
#2	PKG/12	452102	#18	PKG/12	452118	#34	PKG/12	452134	#50	PKG/12	452150
#3	PKG/12	452103	#19	PKG/12	452119	#35	PKG/12	452135	#51	PKG/12	452151
#4	PKG/12	452104	#20	PKG/12	452120	#36	PKG/12	452136	#52	PKG/12	452152
#5	PKG/12	452105	#21	PKG/12	452121	#37	PKG/12	452137	#53	PKG/12	452153
#6	PKG/12	452106	#22	PKG/12	452122	#38	PKG/12	452138	#54	PKG/12	452154
#7	PKG/12	452107	#23	PKG/12	452123	#39	PKG/12	452139	#55	PKG/12	452155
#8	PKG/12	452108	#24	PKG/12	452124	#40	PKG/12	452140	#56	PKG/12	452156
#9	PKG/12	452109	#25	PKG/12	452125	#41	PKG/12	452141	#57	PKG/12	452157
#10	PKG/12	452110	#26	PKG/12	452126	#42	PKG/12	452142	#58	PKG/12	452158
#11	PKG/12	452111	#27	PKG/12	452127	#43	PKG/12	452143	#59	PKG/12	452159
#12	PKG/12	452112	#28	PKG/12	452128	#44	PKG/12	452144	#60	PKG/12	452160
#13	PKG/12	452113	#29	PKG/12	452129	#45	PKG/12	452145			
#14	PKG/12	452114	#30	PKG/12	452130	#46	PKG/12	452146			
#15	PKG/12	452115	#31	PKG/12	452131	#47	PKG/12	452147			

LETTER SIZE #300 HIGH SPEED OXIDE



SIZE	UNIT	STOCK NO.	SIZE	UNIT	STOCK NO.	SIZE	UNIT	STOCK NO.	SIZE	UNIT	STOCK NO.
A	PKG/12	452001	H	PKG/12	452008	O	PKG/6	452015	V	PKG/6	452022
B	PKG/12	452002	I	PKG/6	452009	P	PKG/6	452016	W	PKG/6	452023
C	PKG/6	452003	J	PKG/6	452010	Q	PKG/6	452017	X	PKG/6	452024
D	PKG/6	452004	K	PKG/6	452011	R	PKG/6	452018	Y	PKG/6	452025
E	PKG/6	452005	L	PKG/6	452012	S	PKG/6	452019	Z	PKG/6	452026
F	PKG/6	452006	M	PKG/6	452013	T	PKG/6	452020			
G	PKG/6	452007	N	PKG/6	452014	U	PKG/6	452021			

FRACTIONAL SIZE #300 HIGH SPEED OXIDE



SIZE	UNIT	STOCK NO.	SIZE	UNIT	STOCK NO.	SIZE	UNIT	STOCK NO.	SIZE	UNIT	STOCK NO.
3/64"	PKG/12	455003	11/64"	PKG/12	455011	19/64"	PKG/6	455019	27/64"	PKG/6	455027
1/16"	PKG/12	455004	3/16"	PKG/12	455012	5/16"	PKG/6	455020	7/16"	PKG/6	455028
5/64"	PKG/12	455005	13/64"	PKG/12	455013	21/64"	PKG/6	455021	29/64"	PKG/6	455029
3/32"	PKG/12	455006	7/32"	PKG/12	455014	11/32"	PKG/6	455022	15/32"	PKG/6	455030
7/64"	PKG/12	455007	15/64"	PKG/12	455015	23/64"	PKG/6	455023	31/64"	PKG/6	455031
1/8"	PKG/12	455008	1/4"	PKG/12	455016	3/8"	PKG/6	455024	1/2"	PKG/6	455032
9/64"	PKG/12	455009	17/64"	PKG/12	455017	25/64"	PKG/6	455025			
5/32"	PKG/12	455010	9/32"	PKG/6	455018	13/32"	PKG/6	455026			

⚠ WARNING

To prevent the possibility of serious bodily injury:
 * DO NOT EXCEED the working load limits

DRILL BITS

METRIC GENERAL PURPOSE #301 HIGH SPEED STEEL



SIZE	UNIT	STOCK NO.	SIZE	UNIT	STOCK NO.	SIZE	UNIT	STOCK NO.	SIZE	UNIT	STOCK NO.
5.0MM	PKG/12	450500	7.5MM	PKG/6	450750	10.0MM	PKG/6	451000	12.5MM	PKG/6	451250
5.5MM	PKG/12	450550	8.0MM	PKG/6	450800	10.5MM	PKG/6	451050	13.0MM	PKG/6	451300
6.0MM	PKG/12	450600	8.5MM	PKG/6	450850	11.0MM	PKG/6	451100			
6.5MM	PKG/12	450650	9.0MM	PKG/6	450900	11.5MM	PKG/6	451150			
7.0MM	PKG/12	450700	9.5MM	PKG/6	450950	12.0MM	PKG/6	451200			

SHANK DRILL BITS #303 HIGH SPEED STEEL 1/2" SHANK



SIZE	UNIT	STOCK NO.	SIZE	UNIT	STOCK NO.	SIZE	UNIT	STOCK NO.	SIZE	UNIT	STOCK NO.
33/64"	EA	453033	43/64"	EA	453043	53/64"	EA	453053	63/64"	EA	453063
17/32"	EA	453034	11/16"	EA	453044	37/32"	EA	453054	1"	EA	453064
35/64"	EA	453035	45/64"	EA	453045	55/64"	EA	453055	1 1/16"	EA	453068
9/16"	EA	453036	23/32"	EA	453046	7/8"	EA	453056	1 1/8"	EA	453072
37/64"	EA	453037	47/64"	EA	453047	57/64"	EA	453057	1 1/4"	EA	453080
19/32"	EA	453038	3/4"	EA	456048	29/32"	EA	453058	1 5/16"	EA	453084
39/64"	EA	453039	49/64"	EA	453049	59/64"	EA	453059	1 3/8"	EA	453088
5/8"	EA	453040	25/32"	EA	453050	15/16"	EA	453060	1 1/2"	EA	453096
41/64"	EA	453041	51/64"	EA	453051	61/64"	EA	453061			
21/32"	EA	453042	13/16"	EA	453052	31/32"	EA	453062			

VENT DRILL BITS #380 HIGH SPEED STEEL



SIZE	UNIT	STOCK NO.	SIZE	UNIT	STOCK NO.	SIZE	UNIT	STOCK NO.
69X3	PKG/12	452303	55X6.25	PKG/12	452315	1/16X4	PKG/12	452315
55X4.5	PKG/12	452314	57X6	PKG/12	452316	1/16X6	PKG/12	452320

DRILL INDEX



SIZE	DESCRIPTION	UNIT	STOCK NO.
#1 - #60	NUMBER HIGH SPEED, 60 PC SET	BOX	452502
1/16" - 1/2"	FRACTIONAL HIGH SPEED, 29 PC SET	BOX	452500
A - Z	LETTER HIGH SPEED, 26 PC SET	BOX	452501

WARNING

To prevent the possibility of serious bodily injury:
* DO NOT EXCEED the working load limits

ABRASIVES

CUT OFF BLADE



SIZE	WEIGHT	UNIT	CASE PKG	STOCK NO.
9" X 1/8" X 1"	1.00 LBS	EA	20	461109
12" X 1/8" X 1"	1.25 LBS	EA	25	461112
14" X 1/8" X 1"	2.00 LBS	EA	25	461114
16" X 1/8" X 1"	2.75 LBS	EA	40	461116



WIRE BRUSH

SIZE	WEIGHT	UNIT	CASE PKG	STOCK NO.
19"	0.26 LBS	EA	12	475082
12"	0.29 LBS	EA	12	475083

GRINDING DISK



SIZE	WEIGHT	UNIT	CASE PKG	STOCK NO.
4" X 1/4" X 5/8"	0.16 LBS	EA	100	461040
4 1/2" X 1/4" X 7/8"	0.25 LBS	EA	100	461045
5" X 1/4" X 7/8"	0.40 LBS	EA	100	461050
7" X 1/4" X 5/8"-11"	1.00 LBS	EA	100	461070
9" X 1/4" X 5/8"-11"	1.60 LBS	EA	100	461090

GRINDING WHEEL



SIZE	WEIGHT	UNIT	CASE PKG	STOCK NO.
6" X 3/4" X 1"	0.75 LBS	EA	20	462065
8" X 1" X 1"	1.70 LBS	EA	10	462080
8" X 1/2" X 1 1/4" GR 60	1.70 LBS	EA	10	462084
8" X 1/2" X 1 1/4" GR 46	1.70 LBS	EA	10	462085
10" X 1" X 1"	2.60 LBS	EA	5	462100

WIRE WHEEL



SIZE	WEIGHT	UNIT	CASE PKG	STOCK NO.
6"	0.44 LBS	EA	50	464060
8"	0.58 LBS	EA	50	464080

WARNING

To prevent the possibility of serious bodily injury:
 • DO NOT EXCEED the working load limits

TIE WIRE

TIE WIRE

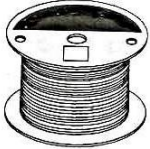

SIZE	DESCRIPTION	WEIGHT	UNIT	STOCK NO.
9 GA	100 LB COIL	100.00 LBS	CL	904075
16 GA	3 1/2 LB SPOOL	3.50 LBS	SP	904085
16 GA	5 LB SPOOL	5.00 LBS	SP	904086
18 GA	5 LB SPOOL	5.00 LBS	SP	904088
20 GA	5 LB SPOOL	5.00 LBS	SP	904092

KLEIN® LIGHTWEIGHT TIE WIRE REEL



SIZE	WEIGHT	UNIT	STOCK NO.
6 1/4" X 2 15/16"	2.10 LBS	EA	904099

WIRE TIES

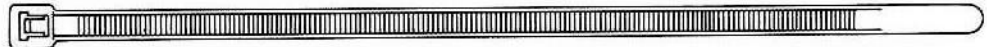

LENGTH	STRENGTH	COLOR	WEIGHT	UNIT	PKG QTY	STOCK NO.
8"	50 LBS	NATURAL	2.50 LBS	PK	1,000 PCS	145054
8"	50 LBS	BLACK	2.50 LBS	PK	1,000 PCS	145054B
12"	175 LBS	NATURAL	1.00 LBS	PK	100 PCS	145058
14"	50 LBS	NATURAL	4.5 LBS	PK	500 PCS	145051
14"	175 LBS	NATURAL	9.00 LBS	PK	100 PCS	145059
14"	75 LBS	BLACK	9.00 LBS	PK	1,000 PCS	145052
14"	50 LBS	GREEN	0.50 LBS	PK	100 PCS	145064G
14"	50 LBS	RED	0.60 LBS	PK	100 PCS	145064R
18"	120 LBS	NATURAL	0.75 LBS	PK	50 PCS	145061
18"	175 LBS	YELLOW	1.00 LBS	PK	50 PCS	145068Y
21"	175 LBS	NATURAL	9.00 LBS	PK	50 PCS	145053
24"	175 LBS	NATURAL	1.25 LBS	PK	50 PCS	145056
24"	175 LBS	BLACK	1.00 LBS	PK	50 PCS	145055
36"	120 LBS	NATURAL	2.00 LBS	PK	50 PCS	145080

WARNING

To prevent the possibility of serious bodily injury:
 • DO NOT EXCEED the working load limits

TRAILER PARTS & ACCESSORIES

CHROME BALL



SIZE	DESCRIPTION	WEIGHT	UNIT	STOCK NO.
1 7/8" X 3/4"	BALL W/BOLT	1.75 LBS	EA	430005
2" X 3/4"	BALL W/BOLT	2.08 LBS	EA	430006
1 7/8" X 3/4"	CHROME BALL	1.44 LBS	EA	430015
2" X 3/4" X 1 3/4"	CHROME BALL	2.29 LBS	EA	430017
2 5/16" X 1 1/4"	CHROME BALL	2.16 LBS	EA	430018
2" X 3/4"	LONG SHANK	2.08 LBS	EA	430019
2 5/16" X 1 1/4"	CHROME BALL 30,000 LBS	2.16 LBS	EA	430039
2" X 1"	CHROME BALL	2.00 LBS	EA	430041
2 5/16" X 1"	CHROME BALL	3.00 LBS	EA	430042
2 5/16" X 1 1/4"	CHROME BALL	4.50 LBS	EA	430043
2 5/16" X 1"	HIGH RISE BH1	6.00 LBS	EA	430010
2 5/16" X 2"	HIGH RISE BH2	8.25LBS	EA	430011

STRAIGHT TONGUE COUPLER



SIZE	DESCRIPTION	WEIGHT	UNIT	STOCK NO.
1 7/8"	2" WIDE, 1 7/8" BALL, 11200	1.46 LBS	EA	430110
1 7/8"	2 1/2" WIDE, 1 7/8" BALL, 11250	1.46 LBS	EA	430115
2"	2" WIDE, 2" BALL, 22200	1.35 LBS	EA	430120
2"	2 1/2" WIDE, 2" BALL, 22250	1.35 LBS	EA	430125

50 DEGREE A -FRAME COUPLER



SIZE	DESCRIPTION	WEIGHT	UNIT	STOCK NO.
2 5/16"	CLASS IV, 10,000LB GTW	8.50 LBS	EA	430155
2"	CLASS III, 5,000 LB GTW	6.00 LBS	EA	430160

WARNING

To prevent the possibility of serious bodily injury:
 • DO NOT EXCEED the working load limits

TRAILER PARTS & ACCESSORIES

FOOTPLATE



SIZE	DESCRIPTION	WEIGHT	UNIT	STOCK NO.
2"	2,000# CAP., FOR 2" JACK TUBE	2.00 LBS	EA	430922
4 1/2" X 2 1/4"	10,000# CAP., 8" TALL	.50 LBS	EA	430924

DUAL PURPOSE PINTLE HITCH



DO NOT WELD OR MODIFY

BALL SIZE	WEIGHT	UNIT	BALL HITCH CAPACITY	PINTLE HOOK CAPACITY	STOCK NO.
1 7/8"	13.00 LBS	EA	8,000 LBS	N/A	430230
2"	13.00 LBS	EA	10,000 LBS	16,000 LBS	430231
2 5/16"	14.00 LBS	EA	10,000 LBS	16,000 LBS	430232

REPLACEMENT BALL (FOR DUAL-PURPOSE PINTLE HITCH)



SIZE	WEIGHT	UNIT	STOCK NO.
1 7/8"	2.00 LBS	EA	430230RB
2"	2.00 LBS	EA	430231RB
2 5/16"	2.00 LBS	EA	430232RB

HITCH PIN



SIZE	DESCRIPTION	WEIGHT	UNIT	STOCK NO.
1/2"	PIN & SPRING CLIP	0.50 LBS	EA	430927
5/8"	PIN & SPRING CLIP	0.50 LBS	EA	430930
5/8"	LOCKING	0.50 LBS	EA	430928

WARNING

To prevent the possibility of serious bodily injury:
 • DO NOT EXCEED the working load limits

TRAILER PARTS & ACCESSORIES



HITCH BOLT KIT

SIZE	WEIGHT	UNIT	STOCK NO.
3/4"	1.00 LBS	KIT	430235



DOUBLE BALL MOUNT

SIZE	BALL SIZES	WEIGHT	UNIT	STOCK NO.
2" X 8"	1 7/8" & 2"	17.00 LBS	EA	430522
2" X 8"	1 7/8" & 2 5/16"	17.25 LBS	EA	430523
2" X 8"	2" & 2 5/16"	17.50 LBS	EA	430525

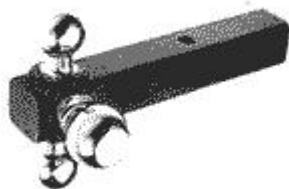

TRIPLE BALL MOUNT

SIZE	BALL SIZES	WEIGHT	UNIT	STOCK NO.
2" X 8"	1 7/8", 2", 2 5/16"	19.50 LBS	EA	430524

BALL MOUNT, CLASS IV (2" SQUARE TUBING, 1" BALL HOLE)



SIZE	RISE	WEIGHT	UNIT	STOCK NO.
2" X 6"	3/4"	7.00 LBS	EA	430562
4" X 6"	2"	8.00 LBS	EA	430564
4" X 10"	2"	10.00 LBS	EA	430566
6" X 10"	4 3/4"	12.10 LBS	EA	430568
8" X 10"	6 3/4"	14.00 LBS	EA	430570
10" X 10"	8 1/2"	15.85 LBS	EA	430572

 WARNING
To prevent the possibility of serious bodily injury: • DO NOT EXCEED the working load limits

TRAILER PARTS & ACCESSORIES

PINTLE ADAPTER

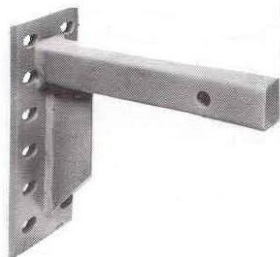

SIZE	DESCRIPTION	WEIGHT	UNIT	STOCK NO.
9" X 7"	8 HOLES	16.00 LBS	EA	430650
12 1/4" X 4"	8 HOLES	16.00 LBS	EA	430652
12 1/4" X 7"	4 HOLES	18.00 LBS	EA	430653
12 1/4" X 11"	12 HOLES	21.50 LBS	EA	430655
12 1/4" X 12"	14 HOLES	24.00 LBS	EA	430659

RIGID MOUNT PINTLE HOOK (USE WITH DRAWBAR DIA. 2 3/8" TO 3" ID)



SIZE	WEIGHT	UNIT	STOCK NO.
5 TON	9.00 LBS	EA	430605
7 TON	9.00 LBS	EA	430606
15 TON	10.00 LBS	EA	430607
20 TON	12.25 LBS	EA	430608
30 TON	24.00 LBS	EA	430609
40 TON	44.00 LBS	EA	430610

SPRING MOUNT PINTLE HOOK (USE WITH DRAWBAR DIA. 2 3/8" TO 3" ID)



SIZE	DESCRIPTION	WEIGHT	UNIT	STOCK NO.
15 TON	SPRING MOUNT	33.50 LBS	EA	430620
25 TON	SPRING MOUNT	34.50 LBS	EA	430625
15 TON	REPLACEMENT SPRING	4.00 LBS	EA	430621

SWIVEL MOUNT PINTLE HOOK (USE WITH DRAWBAR DIA. 2 3/8" TO 3" ID)



SIZE	WEIGHT	UNIT	STOCK NO.
8 TON	15.00 LBS	EA	430630
10 TON	23.00 LBS	EA	4306061
15 TON	27.00 LBS	EA	430635
25 TON	28.00 LBS	EA	430638
30 TON	38.00 LBS	EA	430640
50 TON	61.00 LBS	EA	430644

WARNING

To prevent the possibility of serious bodily injury:
 * DO NOT EXCEED the working load limits

TRAILER PARTS & ACCESSORIES

RECEIVER TUBE



SIZE	DESCRIPTION	WEIGHT	UNIT	STOCK NO.
6"	FOR 2" HITCHBAR	3.48 LBS	EA	430806
10"	FOR 2" HITCHBAR	5.60 LBS	EA	430810
12"	FOR 2" HITCHBAR	7.15 LBS	EA	430812
18"	FOR 2" HITCHBAR	10.60 LBS	EA	430818

RING – RECESSED



SIZE	DESCRIPTION	WEIGHT	UNIT	STOCK NO.
1,000 LB	RECESSED	0.26 LBS	EA	430701
1,200 LB	RECESSED	0.42 LBS	EA	430702
3,500 LB	RECESSED	0.60 LBS	EA	430703
5,000 LB	RECESSED	1.24 LBS	EA	430704
5,000 LB	RECESSED SWIVEL	2.50 LBS	EA	430705

RING "D" TYPE TIE DOWN (WITH WELD ON CLIP)



SIZE	WEIGHT	UNIT	STOCK NO.
1/2"	1.00 LBS	EA	430822
5/8"	2.00 LBS	EA	430824
3/4"	3.10 LBS	EA	430826
1"	4.20 LBS	EA	430828

WELD ON "D" RING MARINE TYPE

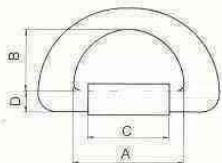

SIZE	DIMENSIONS				WEIGHT	UNIT	STOCK NO.
	A	B	C	D			
36 TON	5 3/8"	3 1/8"	4 3/4"	1 3/16"	5.42 LBS	EA	430831
41 TON	5 5/8"	3 7/16"	4 5/16"	1"	8.15 LBS	EA	430832
50 TON	6"	3 9/16"	5 1/8"	1 1/16"	9.71 LBS	EA	430833

WARNING

To prevent the possibility of serious bodily injury:
 * DO NOT EXCEED the working load limits

TRAILER PARTS & ACCESSORIES

TOW RING



TOW RING
430766



TOW RING
430760-430765

SIZE	WEIGHT	UNIT	STOCK NO.
2 1/2"	10.00 LBS	EA	430760
3"	15.00 LBS	EA	430765
2 1/2"	20.00 LBS	EA	430766
2 1/2"	4.00 LBS	EA	430770
2 1/2"	7.00 LBS	EA	430775
3"	21.00 LBS	EA	430789



TOW RING
430770-430775



TOW RING
430789

TOW HOOK



TOW HOOK
430751



TOW HOOK
430753

SIZE	DESCRIPTION	WEIGHT	UNIT	STOCK NO.
2 1/2"X4 1/2"X2 3/4"	RIGHT & LEFT 074	4.00 LBS	EA	430751
3"X4 3/16"X1 1/2"	RIGHT & LEFT 053	8.00 LBS	EA	430753
2 1/2"X4 3/16"X1 1/2"	LEFT 55	5.00 LBS	EA	430755L
2 1/2"X4 3/16"X1 1/2"	RIGHT 55	5.00 LBS	EA	430755R
1 7/8"X1 15/16"X1 1/8"	RIGHT & LEFT 57	1.60 LBS	EA	430757



TOW HOOK
430755,430755L,430755R



TOW HOOK
430757,430757L,430757R

CHROME TOW HOOK



TOW HOOK CHROME
430759



TOW HOOK CHROME
430759P

SIZE	WEIGHT	UNIT	STOCK NO.
10,000 LBS	1.75 LBS	EA	430759
10,000 LBS	3.50 LBS	PAIR	430759P

BOAT WINCH



BOAT WINCH
430968

SIZE	WEIGHT	UNIT	STOCK NO.
1,200 LBS	3.00 LBS	EA	430963
1,800 LBS	12.12 LBS	EA	430968
2,500 LBS	13.23 LBS	EA	430978



BOAT WINCH
430978

WARNING

To prevent the possibility of serious bodily injury:
* DO NOT EXCEED the working load limits

TARPAULINS & STRAPS

BLUE POLYETHYLENE TARP



SIZE	WEIGHT	UNIT	STOCK NO.	SIZE	WEIGHT	UNIT	STOCK NO.
5' X 7'	0.70 LBS	EA	417100	16' X 20'	6.00 LBS	EA	417350
8' X 10'	1.30 LBS	EA	417150	18' X 24'	7.70 LBS	EA	417380
8' X 12'	1.70 LBS	EA	417160	20' X 20'	9.00 LBS	EA	417500
8' X 15'	2.40 LBS	EA	417161	20' X 25'	9.25 LBS	EA	417505
9' X 12'	1.90 LBS	EA	417170	20' X 30'	11.00 LBS	EA	417510
10' X 12'	2.20 LBS	EA	417200	20' X 35'	11.40 LBS	EA	417520
10' X 15'	2.60 LBS	EA	417201	20' X 40'	13.60 LBS	EA	417530
10' X 18'	3.15 LBS	EA	417210	24' X 36'	17.50 LBS	EA	417550
10' X 20'	3.65 LBS	EA	417220	25' X 25'	17.50 LBS	EA	417575
12' X 12'	2.50 LBS	EA	417240	25' X 40'	17.70 LBS	EA	417600
12' X 16'	3.90 LBS	EA	417250	30' X 40'	26.60 LBS	EA	417610
12' X 20'	4.15 LBS	EA	417260	30' X 50'	28.00 LBS	EA	417620
12' X 25'	5.00 LBS	EA	417270	30' X 60'	34.60 LBS	EA	417630
15' X 20'	5.25 LBS	EA	417300	40' X 40'	31.00 LBS	EA	417690
15' X 30'	9.00 LBS	EA	417310	50' X 100'	82.00 LBS	EA	417800

RUBBER TARP STRAP - EDM



SIZE	WEIGHT	UNIT	PKG QTY	STOCK NO.
10"	0.13 LBS	EA	100	143010
15"	0.14 LBS	EA	100	143015
21"	0.15 LBS	EA	100	143021
31"	0.17 LBS	EA	100	143031
41"	0.46 LBS	EA	100	143041

⚠ WARNING

To prevent the possibility of serious bodily injury:
 • DO NOT EXCEED the working load limits

SNAPS



RIGID ROUND EYE SNAP – 125

SIZE	DIMENSIONS			WEIGHT	UNIT	STOCK NO.
	A	B	C			
5/8"	5/8"	3 3/8"	5/16"	0.09LBS	EA	652902
3/4"	3/4"	3 1/2"	5/16"	0.095 LBS	EA	652903
1"	1"	3 9/16"	5/16"	0.10 LBS	EA	652904

DOUBLE PATTERN SNAP – 161



SIZE	DIMENSIONS			WEIGHT	UNIT	STOCK NO.
	LOOP	INSIDE	OPENING			
161	9/32"	3 7/16"	9/32"	.085 LBS	EA	653202
162	3/8"	4"	3/8"	.115 LBS	EA	653203
163	7/16"	4 5/8"	7/16"	.135 LBS	EA	653204

SWIVEL EYE BOLT SNAP – 225



SIZE	DIMENSIONS			WEIGHT	UNIT	STOCK NO.
	A	B	C			
5/8"	5/8"	4"	3/8"	0.13 LBS	EA	650201
3/4"	3/4"	4 1/8"	3/8"	0.14 LBS	EA	650202
1"	1"	4 3/4"	7/8"	0.24 LBS	EA	650203
1 1/4"	1 1/4"	5"	7/8"	0.27 LBS	EA	650204

RIGID OPEN EYE SNAP – 230



SIZE	DIMENSIONS			WEIGHT	UNIT	STOCK NO.
	A	B	C			
230	3/8"	3 5/16"	11/32"	0.10 LBS	EA	651101
232	1/2"	4"	7/16"	0.15 LBS	EA	651103

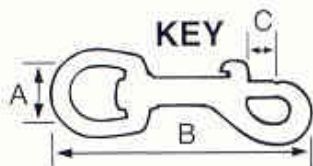

WARNING

To prevent the possibility of serious bodily injury:
 • **DO NOT EXCEED** the working load limits

SNAPS

RIGID EYE SNAP – 249



SIZE	DIMENSIONS			WEIGHT	UNIT	STOCK NO.
	A	B	C			
1	3/8"	2 1/8"	1/4"	.064 LBS	EA	650396
2	5/8"	2 7/8"	15/16"	0.10 LBS	EA	650397
3	11/16"	3 1/4"	1/2"	0.14 LBS	EA	650398
4	3/4"	3 3/4"	5/8"	.245 LBS	EA	650399

SWIVEL EYE SNAP – 251



SIZE	DIMENSIONS			WEIGHT	UNIT	STOCK NO.
	A	B	C			
1	5/8"	3 1/4"	3/8"	0.14 LBS	EA	650403
2	3/4"	3 3/4"	1/2"	0.20 LBS	EA	650404
3	3/4"	4 1/2"	9/16"	0.27 LBS	EA	650405

SWIVEL TRIGGER SNAP – 5013



SIZE	DIMENSIONS			WEIGHT	UNIT	STOCK NO.
	A	B	C			
3/8"	3/8"	2 7/16"	3/8"	0.08 LBS	EA	653301
1/2"	1/2"	2 9/16"	3/8"	.075 LBS	EA	653302
5/8"	5/8"	2 7/16"	3/8"	.075 LBS	EA	653303
3/4"	3/4"	2 1/2"	3/8"	0.08 LBS	EA	653304

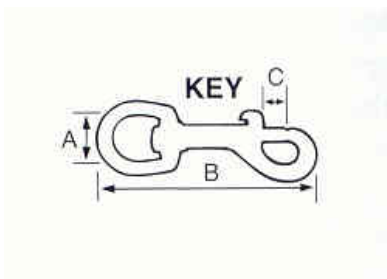

⚠ WARNING
To prevent the possibility of serious bodily injury: <ul style="list-style-type: none"> • DO NOT EXCEED the working load limits

THIMBLES

GALVANIZED HEAVY DUTY THIMBLE



SIZE	WEIGHT	UNIT	STOCK NO.
1/4"	0.07 LBS	EA	852008
5/16"	0.12 LBS	EA	852010
3/8"	0.22 LBS	EA	852012
7/16"	0.35 LBS	EA	852014
1/2"	0.51 LBS	EA	852016
9/16"	0.51 LBS	EA	852018
5/8"	0.75 LBS	EA	852020
3/4"	1.54 LBS	EA	852024
7/8"	1.78 LBS	EA	852028
1"	3.14 LBS	EA	852032
1 1/8" - 1 1/4"	4.00 LBS	EA	852036
1 1/4" - 1 3/8"	8.11 LBS	EA	852040
1 3/8" - 1 1/2"	12.95 LBS	EA	852044
1 3/4"	17.75 LBS	EA	852056
1 7/8" - 2"	27.75 LBS	EA	852060
2 1/4"	39.50 LBS	EA	852072

GALVANIZED LIGHT DUTY THIMBLE

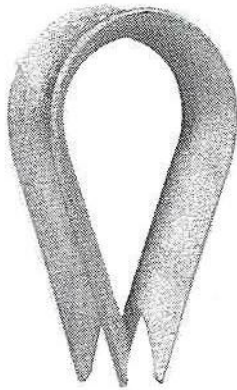

SIZE	WEIGHT	UNIT	STOCK NO.
1/16"	0.04 LBS	EA	853002
1/8"	0.04 LBS	EA	853004
3/16"	0.04 LBS	EA	853006
1/4"	0.04 LBS	EA	853008
5/16"	0.04 LBS	EA	853010
3/8"	0.07 LBS	EA	853012
7/16"	0.07 LBS	EA	853014
1/2"	0.12 LBS	EA	853016
9/16"	0.35 LBS	EA	853018
5/8"	0.35 LBS	EA	853020
3/4"	0.47 LBS	EA	853024
7/8"	0.85 LBS	EA	853028
1"	0.97 LBS	EA	853032
1 1/8" - 1 1/4"	1.75 LBS	EA	853036

WARNING

To prevent the possibility of serious bodily injury:
 • **DO NOT EXCEED** the working load limits

THIMBLES

PLASTIC TEARDROP THIMBLE



SIZE	WEIGHT	UNIT	STOCK NO.
3/8"	0.02 LBS	EA	857512
1/2"	0.04 LBS	EA	857516
5/8"	0.05 LBS	EA	857520

ROUND PLASTIC THIMBLE



SIZE	WEIGHT	UNIT	STOCK NO.
1/2"	0.01 LBS	EA	857616
5/8"	0.02 LBS	EA	857620

METAL SYNTHETIC ROPE THIMBLE



SIZE	WEIGHT	UNIT	STOCK NO.
1/2"	0.10 LBS	EA	857216
5/8"	0.20 LBS	EA	857220
3/4"	0.22 LBS	EA	857224
1"	0.25 LBS	EA	857232

BRONZE THIMBLE

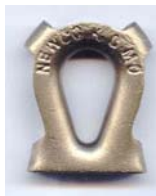

SIZE	WEIGHT	UNIT	STOCK NO.
3/8"	0.20 LBS	EA	857712
1/2"	0.25 LBS	EA	857716
5/8"	0.60 LBS	EA	857720
1"	1.50 LBS	EA	857732
1 1/8"	2.10 LBS	EA	857736

WARNING

To prevent the possibility of serious bodily injury:
 • **DO NOT EXCEED** the working load limits

U-BOLTS

ROUND, ELECTRO ZINC PLATED (WITH PLATE)

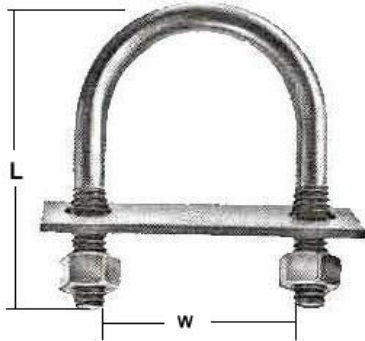

SIZE	WIDTH	LENGTH	FITS PIPE SIZE	WEIGHT	UNIT	STOCK NO.
1/4"	1"	1 3/4"	1/2"	0.09 LBS	EA	219504
1/4"	1 1/8"	2"	3/4"	0.09 LBS	EA	219505
1/4"	1 1/8"	3 1/8"	3/4"	0.10 LBS	EA	219505L
1/4"	1 1/2"	2 3/4"	1"	0.10 LBS	EA	219507
5/16"	1 3/8"	2 3/16"	1"	0.12 LBS	EA	219511
5/16"	1 3/8"	3 5/8"	1"	0.16 LBS	EA	219511L
5/16"	1 3/4"	2 11/16"	1 1/4"	0.18 LBS	EA	219513
5/16"	1 3/4"	4 1/2"	1 1/4"	0.19 LBS	EA	219513L
5/16"	2"	2 11/16"	1 1/2"	0.19 LBS	EA	219514
5/16"	2"	4 3/4"	1 1/2"	0.20 LBS	EA	219521
5/16"	2 1/2"	3 3/16"	2"	0.21 LBS	EA	219515
5/16"	2 1/2"	5 5/8"	2"	0.22 LBS	EA	219515L
3/8"	2 1/2"	3 1/8"	2"	0.33 LBS	EA	219522
3/8"	3 1/2"	4 1/8"	3"	0.43 LBS	EA	219524

ROUND, ELECTRO ZINC PLATED (WITHOUT PLATE)

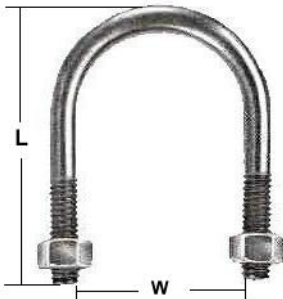

SIZE	WIDTH	LENGTH	FITS PIPE SIZE	WEIGHT	UNIT	STOCK NO.
1/4"	1 1/2"	2 3/4"	1"	0.12 LBS	EA	219510
1/4"	2"	3 1/4"	1 1/2"	0.09 LBS	EA	219509
5/16"	2"	4 3/4"	1 1/2"	0.14 LBS	EA	219520
3/8"	1 1/4"	2 1/4"	3/4"	0.18 LBS	EA	219518
1/2"	4"	5 1/2"	3 1/2"	0.14 LBS	EA	219527

SQUARE, ELECTRO ZINC PLATED (WITHOUT PLATE)

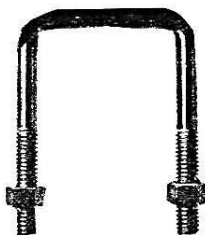

SIZE/THREAD	OVERALL SIZE	WEIGHT	UNIT	STOCK NO.
3/8"-16	3/8" X 2" X 5"	0.34 LBS	EA	219622
3/8"-16	3/8" X 4" X 5"	0.39 LBS	EA	219625
3/8"-16	3/8" X 4" X 7"	0.49 LBS	EA	219626
3/8"-16	3/8" X 6" X 5"	0.44 LBS	EA	219627
3/8"-16	3/8" X 6" X 9"	0.63 LBS	EA	219629

WARNING

To prevent the possibility of serious bodily injury:
 • DO NOT EXCEED the working load limits

PADS EYES & EYE NUTS

WELDABLE PAD EYE



SIZE	WEIGHT	UNIT	STOCK NO.
#0	0.03 LBS	EA	216000
#1	0.07 LBS	EA	216001
#1 1/2	0.11 LBS	EA	216001.5
#2	0.21 LBS	EA	216002
#4	0.52 LBS	EA	216004
#5	0.82 LBS	EA	216005

***NOT RECOMMENDED FOR LIFTING**

EYE NUT, HD GALVANIZED



BAIL SIZE	TAP SIZE	WEIGHT	UNIT	WORKING LOAD LIMIT	STOCK NO.
1/4"	1/4"-20	0.09 LBS	EA	520 LBS	213008I
1/4"	5/16"-16	0.17 LBS	EA	1,240 LBS	213010I
5/16"	3/8"-16	0.22 LBS	EA	2,240 LBS	213012I
3/8"	1/2"-13	0.28 LBS	EA	2,240 LBS	213016I
1/2"	5/8"-11	0.58 LBS	EA	3,600 LBS	213020I
5/8"	5/8"-11	1.00 LBS	EA	5,200 LBS	213025I
5/8"	3/4"-10	1.00 LBS	EA	5,200 LBS	213024I
3/4"	7/8"-9	1.32 LBS	EA	7,200 LBS	213028I
7/8"	1"-8	2.69 LBS	EA	7,200 LBS	213032I
#8	1"-1 1/4	3.85 LBS	EA	15,500 LBS	213041I

***NOT RECOMMENDED FOR OVERHEAD LIFTING**

ROD END



SIZE	WEIGHT	UNIT	STOCK NO.
1" X 12"	3.50 LBS	EA	21703212
1 1/4" X 12"	5.75 LBS	EA	21704012

WARNING

To prevent the possibility of serious bodily injury:
*** DO NOT EXCEED** the working load limits

YOKES

ADJUSTABLE YOKE (RIGHT HAND THREADS)



SIZE THREAD	WEIGHT	UNIT	STOCK NO.
1/4" - 28 NF	0.07 LBS	EA	217008
5/16"-24 NF	0.11 LBS	EA	217010
3/8" - 24 NF	0.16 LBS	EA	217012.1
7/16"- 20 NF	0.24 LBS	EA	217014
1/2" - 13 NC	0.39 LBS	EA	217016
1/2" - 20 NF	0.32 LBS	EA	217016.1
5/8" - 11 NF	0.75 LBS	EA	217020
3/4" - 10 NC	1.25 LBS	EA	217018
3/4" - 16 NF	1.35 LBS	EA	217019

PLAIN END YOKE (SELF-COLORED, FORGED CARBON STEEL)



SIZE	WEIGHT	UNIT	STOCK NO.
1/4"	0.14 LBS	EA	217158
5/16"	0.18 LBS	EA	217160
3/8" - 7"L	0.58 LBS	EA	217161
3/8" - 3.5"L	0.28 LBS	EA	217162
1/2"	0.51 LBS	EA	217166
5/8"	0.76 LBS	EA	217170
3/4"	1.28 LBS	EA	217174

BRIDGE CLEVIS (SPECIAL ORDER ITEM)



BODY SIZE (INCHES)	WORKING LOAD LIMIT (LBS)	WEIGHT
2"	3,500 LBS	1.00 LBS
2 1/2"	7,500 LBS	2.50 LBS
3"	15,000 LBS	4.00 LBS
3 1/2"	18,000 LBS	6.00 LBS
4"	21,000 LBS	8.00 LBS

WHEN ORDERING PLEASE STATE BODY SIZE, CLEVIS SIZE, TAP SIZE, AND PIN SIZE.

⚠ WARNING
To prevent the possibility of serious bodily injury: • DO NOT EXCEED the working load limits

HOSE



PVC DISCHARGE HOSE (SOLD IN ROLLS ONLY, NO CUT LENGTHS)

SIZE	WEIGHT	UNIT	STOCK NO.
1 1/2" X 300'	42.00 LBS	FT	420100
2" X 300'	54.00 LBS	FT	420102
3" X 300'	78.00 LBS	FT	420103
4" X 300'	120.00 LBS	FT	420104
6" X 300'	210.00 LBS	FT	420106
8" X 300'	351.00 LBS	FT	420108



PVC SUCTION HOSE (SOLD IN ROLLS ONLY, NO CUT LENGTHS)

SIZE	PSI	WEIGHT	UNIT	STOCK NO.
1 1/4" X 100'	125	32.00 LBS	FT	420451
1 1/2" X 100'	140	39.00 LBS	FT	420452
2" X 100'	95	57.00 LBS	FT	420453
3" X 100'	60	101.00 LBS	FT	420454
4" X 100'	50	160.00 LBS	FT	420455
6" X 100'	40	280.00 LBS	FT	420457

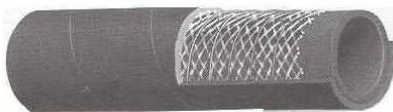

BLACK RUBBER SUCTION HOSE (SOLD IN ROLLS ONLY, NO CUT LENGTHS)

SIZE	PSI	WEIGHT	UNIT	STOCK NO.
1 1/4" X 100'	125	61.00 LBS	FT	420410
1 1/2" X 100'	125	81.00 LBS	FT	420420
2" X 100'	125	106.00 LBS	FT	420430
3" X 100'	90	197.00 LBS	FT	420440
4" X 100'	75	266.00 LBS	FT	420445
6" X 60'	75	329.00 LBS	FT	420446

FIRE HOSE PVC – COUPLED MSHA A & B PINLOCK

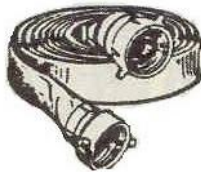

SIZE	FR-MSHA	WEIGHT	UNIT	STOCK NO.
1 1/2" X 50'	150 LBS	12.50 LBS	EA	420151
1 1/2" X 100'	150 LBS	24.00 LBS	EA	420152
1 1/2" X 150'	150 LBS	36.50 LBS	EA	420153
1 1/2" X 200'	150 LBS	48.00 LBS	EA	420154
1 1/2" X 250'	150 LBS	60.50 LBS	EA	420155
1 1/2" X 300'	150 LBS	70.00 LBS	EA	420156

⚠ WARNING

To prevent the possibility of serious bodily injury:
 • **DO NOT EXCEED** the working load limits

HOSE

FIRE HOSE PVC – UNCOUPLED MSHA (SOLD IN ROLLS ONLY, NO CUT LENGTHS)



SIZE	FR-MSHA	WEIGHT	UNIT	STOCK NO.
1 1/2" X 300'	150 LBS	0.134 LBS/FT	FT	420150
2" X 300'	150 LBS	0.184 LBS/FT	FT	420170

AIR & WATER COUPLED



SIZE	DESCRIPTION	PSI	WEIGHT	UNIT	STOCK NO.
1/4" X 25'	RED THERMO, MPT	300	4.00 LBS	EA	420065
1/4" X 50'	RED THERMO	300	9.00 LBS	EA	420069
3/8" X 25'	YELLOW THERMO	300	5.00 LBS	EA	420074
3/8" X 50'	RED PLIOVIC	300	9.00 LBS	EA	420075
1/2" X 50'	RED RUBBER- 1/2" MPT	250	12.50 LBS	EA	420495

GENERAL PURPOSE AIR HOSE (SOLD IN ROLLS ONLY, NO CUT LENGTHS)



SIZE	DESCRIPTION	PSI	WEIGHT	UNIT	STOCK NO.
1/4"	RED RUBBER AIR	300	0.02 LBS/FT	FT	420501
3/8"	RED RUBBER AIR	300	0.03 LBS/FT	FT	420502
1/2"	RED RUBBER AIR	300	0.05 LBS/FT	FT	420503
5/8"	RED RUBBER AIR	300	0.05 LBS/FT	FT	420504
3/4"	RED RUBBER AIR	300	0.06 LBS/FT	FT	420505
1"	RED RUBBER AIR	300	0.07 LBS/FT	FT	420506
1 1/4"	RED RUBBER AIR	300	0.10 LBS/FT	FT	420507

WARNING

To prevent the possibility of serious bodily injury:
 • DO NOT EXCEED the working load limits

HOSE ACCESSORIES

ALUMINUM CAMLOCKS



PART A
MALE ADAPTER X FEMALE NPT



PART B
FEMALE COUPLER X MALE NPT



PART C
FEMALE COUPLER X HOSE SHANK



PART D
FEMALE COUPLER X FEMALE NPT



PART E
MALE ADAPTER X HOSE SHANK



PART F
MALE ADAPTER X MALE NPT



PART DC
DUST CAP



PART DP
DUST PLUG



CAMLOCK GASKET

SIZE	DESCRIPTION	UNIT	STOCK NO.
SEE NOTE	PART A, MALE ADAPTER TO FEMALE NPT	EA	4210*0
SEE NOTE	PART B, FEMALE COUPLER TO MALE NPT	EA	4210*1
SEE NOTE	PART C, FEMALE COUPLER TO HOSE SHANK	EA	4210*2
SEE NOTE	PART D, FEMALE COUPLER TO FEMALE NPT	EA	4210*3
SEE NOTE	PART DC, DUST CAP	EA	4210*4
SEE NOTE	PART DP, DUST PLUG	EA	4210*5
SEE NOTE	PART E, MALE ADAPTER TO HOSE SHANK	EA	4210*6
SEE NOTE	PART F, MALE ADAPTER TO MALE NPT	EA	4210*7
SEE NOTE	GASKET CAMLOCK	EA	4210*9

SIZES AVAILABLE: 3/4" = 1, 1" = 2, 1 1/4" = 3, 1 1/2" = 4, 2" = 5, 2 1/2" = 6, 3" = 7, 4" = 8, 6" = 9

TO ORDER: COMPLETE THE STOCK NUMBER BY INSERTING SIZE NUMBER AS THE 5TH DIGIT: EXAMPLE: PART B FOR 1" HOSE = 421021

WARNING:
 UNDER NO CIRCUMSTANCES
 SHOULD CAM AND GROOVE COUPLINGS
 BE USED FOR COMPRESSED AIR
 OR STEAM SERVICE

SAFETY
 ALERT

HOSE ACCESSORIES

COMBINATION NIPPLE HOSE SHANK, THREAD MALE NPT



SIZE	WEIGHT	UNIT	STOCK NO.
1/2"	0.25 LBS	EA	420510
3/4"	0.31 LBS	EA	420515
1"	0.37 LBS	EA	420520
1 1/4"	0.50 LBS	EA	420525
1 1/2"	0.75 LBS	EA	420530
2"	1.10 LBS	EA	420535
2 1/2"	1.98 LBS	EA	420537
3"	2.75 LBS	EA	420540
4"	4.75 LBS	EA	420545
5"	7.67 LBS	EA	420547
6"	12.00 LBS	EA	420550

HOSE MENDER



SIZE	WEIGHT	UNIT	STOCK NO.
1/2"	0.10 LBS	EA	420560
3/4"	0.15 LBS	EA	420565
1"	0.20 LBS	EA	420570
1 1/4"	0.40 LBS	EA	420575
1 1/2"	0.65 LBS	EA	420580
2"	0.90 LBS	EA	420585
2 1/2"	0.90 LBS	EA	420586
3"	2.75 LBS	EA	420590
4"	3.55 LBS	EA	420595
6"	12.00 LBS	EA	420599

STEEL HOSE MENDER



SIZE	WEIGHT	UNIT	STOCK NO.
1/2"	0.25 LBS	EA	420600
3/4"	0.25 LBS	EA	420601
1"	0.25 LBS	EA	420602
1 1/4"	0.25 LBS	EA	420603
1 1/2"	0.75 LBS	EA	420604

WARNING

To prevent the possibility of serious bodily injury:
 • DO NOT EXCEED the working load limits

HOSE ACCESSORIES

FIRE HOSE NOZZLE

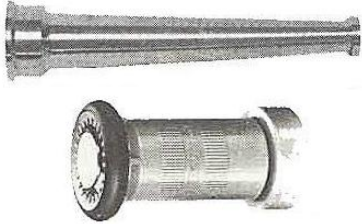

SIZE	DESCRIPTION	THREAD	WEIGHT	UNIT	STOCK NO.
1"X8"	BRASS TAPERED	1" IPT	1.00 LBS	EA	420209
1 1/2"	BRASS FOG	IPT/NST	1.15 LBS	EA	420210
1"	PLASTIC FOG	IPS	0.50 LBS	EA	420211
1 1/2"	ADJ BRASS	IPT	2.00 LBS	EA	420213
1 1/2"	PLASTIC FOG	IPS	0.50 LBS	EA	420220

WATER SUCTION HOSE STRAINER



SIZE	WEIGHT	UNIT	STOCK NO.
1 1/2"	1.50 LBS	EA	420610
2"	2.00 LBS	EA	420615
3"	2.90 LBS	EA	420620
4"	3.00 LBS	EA	420625
6"	6.00 LBS	EA	420630

BRASS "Y" STRAINER

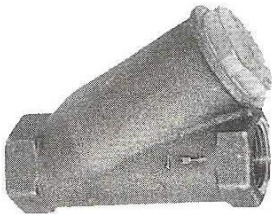

SIZE	WEIGHT	UNIT	STOCK NO.
3/4"	0.90 LBS	EA	420650
1"	1.60 LBS	EA	420655
1 1/4"	2.50 LBS	EA	420660
1 1/2"	3.30 LBS	EA	420665
2"	5.40 LBS	EA	420670
3"	14.00 LBS	EA	420680

WARNING

To prevent the possibility of serious bodily injury:
 • DO NOT EXCEED the working load limits

HOSE ACCESSORIES

WORM GEAR HOSE CLAMP STAINLESS STEEL



SIZE	DESCRIPTION	WEIGHT	UNIT	STOCK NO.
5/16"	5/16"-3/8"	0.10 LBS	EA	420855
3/8"	3/8" - 7/8"	0.10 LBS	EA	420857
7/16"	7/16" - 1"	0.10 LBS	EA	420856
7/16"	COMBO 7/16"-1"	0.10 LBS	EA	420861
3/4"	COMBO 3/4"-1 3/4"	0.10 LBS	EA	420862
7/8"	COMBO 7/8"-2 3/4"	0.10 LBS	EA	420863
1"	COMBO 1"-2"	0.10 LBS	EA	420864
1"	MICRO GEAR 1"-1 1/4"	0.10 LBS	EA	420860
1 5/16"	1 5/16" - 2 1/4"	0.10 LBS	EA	420858
1 5/8"	COMBO 1 5/8"-3 1/2"	0.10 LBS	EA	420865
2"	SINGLE EAR	0.10 LBS	EA	420867
3 3/4"	COMBO 3 3/4"	0.10 LBS	EA	420866

WHIP CHECK



SIZE	WEIGHT	UNIT	STOCK NO.
#1	.14 LBS	EA	420990
#2	.75 LBS	EA	420991

VICTROLIC COUPLING CLAMP

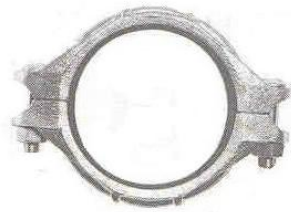

SIZE	WEIGHT	UNIT	STOCK NO.
2"	4.20 LBS	EA	420852
3"	2.80 LBS	EA	420853
4"	4.75 LBS	EA	420854

WARNING

To prevent the possibility of serious bodily injury:
• DO NOT EXCEED the working load limits

VALVES

BRASS BALL VALVE (600 WOG, INTERNATIONAL)



SIZE	WEIGHT	UNIT	STOCK NO.
1/4"	0.35 LBS	EA	425008
3/8"	0.40 LBS	EA	425012
1/2"	0.70 LBS	EA	425016
3/4"	1.06 LBS	EA	425024
1"	1.20 LBS	EA	425032
1 1/4"	1.75 LBS	EA	425040
1 1/2"	2.50 LBS	EA	425048
2"	3.87 LBS	EA	425064
2 1/2"	7.50 LBS	EA	425080
3"	13.33 LBS	EA	425096
4"	17.00 LBS	EA	425097

BRASS GATE VALVE (200 WOG, INTERNATIONAL)



SIZE	WEIGHT	UNIT	STOCK NO.
1/4"	0.54 LBS	EA	425208
3/8"	0.54 LBS	EA	425212
1/2"	0.56 LBS	EA	425216
3/4"	0.85 LBS	EA	425224
1"	1.11 LBS	EA	425232
1 1/4"	1.62 LBS	EA	425240
1 1/2"	2.20 LBS	EA	425248
2"	3.00 LBS	EA	425264
2 1/2"	6.66 LBS	EA	425280
3"	9.16 LBS	EA	425296
4"	13.75 LBS	EA	425297

WARNING

To prevent the possibility of serious bodily injury:
 • **DO NOT EXCEED** the working load limits

VALVES

BRASS SWING CHECK VALVE (200 WOG, INTERNATIONAL)



SIZE	WEIGHT	UNIT	STOCK NO.
3/8"	0.44 LBS	EA	425412
1/2"	0.45 LBS	EA	425416
3/4"	0.57 LBS	EA	425424
1"	0.76 LBS	EA	425432
1 1/4"	1.27 LBS	EA	425440
1 1/2"	1.53 LBS	EA	425448
2"	2.54 LBS	EA	425464
2 1/2"	5.00 LBS	EA	425466
3"	8.00 LBS	EA	425468
4"	12.00 LBS	EA	425470

BRASS FOOT VALVE (INTERNATIONAL)



SIZE	WEIGHT	UNIT	STOCK NO.
1 1/2"	2.75 LBS	EA	425316
2"	4.75 LBS	EA	425320
3"	7.75 LBS	EA	425330
4"	15.25 LBS	EA	425340
6"	21.00 LBS	EA	425360

WARNING

To prevent the possibility of serious bodily injury:
• **DO NOT EXCEED** the working load limits

DECK CLEATS

LIGHT DUTY MALLEABLE CLEAT HOT DIPPED GALVANIZED

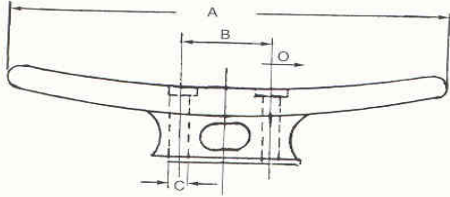

SIZE	DIMENSIONS			BOLT	WEIGHT	UNIT	STOCK NUMBER
	A	B	C				
3 1/2"	3.50"	0.83"	0.22"	#10	0.13 LBS	EA	655503
4"	4.00"	0.91"	0.26"	#12	0.22 LBS	EA	655504
5"	5.00"	1.08"	0.26"	#12	0.33 LBS	EA	655505
6"	5.88"	1.25"	0.31"	1/4"	0.38 LBS	EA	655506
8"	8.00"	1.63"	0.38"	5/16"	1.00 LBS	EA	655508
10"	10.25"	2.38"	0.44"	3/8"	2.00 LBS	EA	655510
12"	12.25"	3.83"	0.44"	3/8"	3.60 LBS	EA	655512
14"	14.31"	4.25"	0.57"	1/2"	5.88 LBS	EA	655514
18"	18.00"	5.38"	0.69"	5/8"	11.00 LBS	EA	655518

HEAVY DUTY MALLEABLE CLEAT HOT DIPPED GALVANIZED

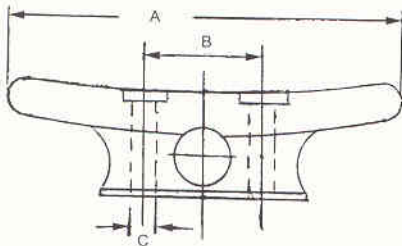

SIZE	DIMENSIONS			BOLT	WEIGHT	UNIT	STOCK NUMBER
	A	B	C				
8"	8.63"	2.00"	0.56"	1/2"	3.25 LBS	EA	655528
10"	10.00"	2.44"	0.56"	1/2"	5.50 LBS	EA	655530
12"	12.00"	3.38"	0.75"	5/8"	10.00 LBS	EA	655532
15"	15.31"	3.56"	0.75"	5/8"	13.25 LBS	EA	655535
18"	18.13"	3.88"	0.75"	5/8"	20.50 LBS	EA	655538

WARNING

To prevent the possibility of serious bodily injury:
 • DO NOT EXCEED the working load limits

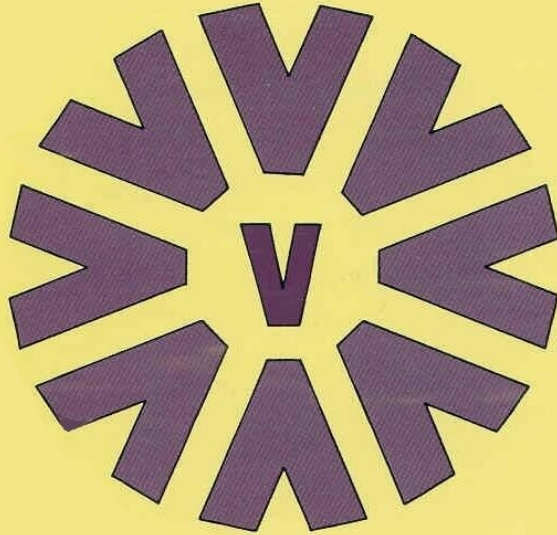

VOLUNTEER
WIRE ROPE & SUPPLY CO., INC.

**2706 John Deere Drive
Knoxville, TN 37917**

PHONE	TOLL FREE	FAX
(865)546-8613	1-800-333-5789	(865)522-6619

**VISIT US ONLINE AT
www.volwire.com**